

**INSTITUTE FOR PLASMA RESEARCH**  
**NEAR INDIRA BRIDGE, BHAT, GANDHINAGAR 382 428**  
**GUJARAT STATE**  
**Phone: 079 23962021, 23962023 Fax: 079 23962277**

**TENDER NOTICE DATED 3-9-2009**

Itemwise sealed tenders are invited from reputed and eligible parties for the following.

| Sr. No | Tender Notice No.                             | Item   | Quantity                            | Due Date & time of opening  | Tender Fee (Rs.) | EMD (Rs.)       |
|--------|---|--|-------------------------------------|-----------------------------|------------------|-----------------|
| 1.     | IPR/TN/PUR/022/09-10                          | 1) SS 304 L Sheets/<br>Plates<br>2) SS304 L Pipes/Tubes/<br>Rods   | As per the tender documents         | 1-10-2009<br>2.30 p.m.      | 200.00           | 15000.00        |
| 2.     | IPR/TN/PUR/023/09-10                          | Cr-Mo Alloy Steel Plate (ASTM A387 Gr91 Class 2) size 8' length x 4' width x 6mm   | 1 No.                               | 7-10-2009<br>2.30 p.m.      | 100.00           | 5000.00         |
| 3.     | IPR/TN/PUR/024/09-10                          | Perforated Aluminium sheets  | 135 Nos.                            | 8-10-2009<br>2.30 p.m.      | 200.00           | 5000,00         |
| 4.     | IPR/TN/PUR/025/09-10                          | Supply of –<br>(a) Abrasive Cutting Machine<br>(b) 12 inches Cut off wheel<br>(c) Cutting oil                                  | 1 No.<br><br>10 Nos.<br><br>3 Ltrs. | 13-10-2009<br>2.30 p.m.     | 100.00           | 5000.00         |
| 5.     | IPR/TN/PUR/026/09-10                          | G-10 (CR) Cryogenics Grade Epoxy Glass Laminate sheet/plate  | As per tender documents             | 14-10-2009<br>2.30 p.m.     | 200.00           | 10000.00        |
| 6.     | <b>IPR/TN/PUR/027/09-10 (TWO PART TENDER)</b> | <b>Manufacture, inspection, testing, supply and commissioning of CNC Single Spindle 3-Axis Horizontal Gun Drilling Machine</b> | <b>1 No.</b>                        | <b>15-10-2009 2.30 p.m.</b> | <b>200.00</b>    | <b>20000.00</b> |

Tender documents are available on IPR Website : [www.ipr.res.in/purchasetenders.html](http://www.ipr.res.in/purchasetenders.html). Tenderers meeting the eligibility criteria mentioned in the tender documents may, at their option, download the tender documents from the website and submit their offer along with prescribed **Tender Fee (non refundable) and EMD** in the form of Demand Draft from any nationalized/scheduled bank drawn in favour of **Institute for Plasma Research** and payable at **Ahmedabad** as per the details given in the tender documents. In case party desires to collect the tender documents by post, they may contact the Purchase Officer along with prescribed tender fee. Tender documents will be issued upto **23-9-2009**. The representative who is going to attend the tender opening should carry an authorization letter from the organization for participation in the tender opening failing which he will not be allowed to attend the tender opening.

**TENDER NOTICE No.IPR/TN/PUR/027/09-10 DATED 3-9-2009**  
**(TWO PART)**

**For Manufacture, inspection, testing, supply and commissioning of  
CNC Single Spindle 3-Axes Horizontal Gun Drilling Machine – 1 No.**

**NOTE: THIS IS A TWO PART TENDER. KINDLY SUBMIT PART-A (TECHNICAL BID & COMMERCIAL TERMS AND CONDITIONS AND (PART-B) PRICE BID SEPARATELY IN TWO DIFFERENT ENVELOPES SUPERSCRIBING TECHNICAL BID AND PRICE BID IN ONE SINGLE ENVELOPE**

**NOTE:**

1. Full details and specifications of the items and general instructions to be followed regarding submission of tenders are indicated in the tender documents.
2. **Proof for fulfillment of eligibility criteria mentioned hereunder should be submitted along with the tender. If the tender is submitted without valid documents, we shall not consider your offer. Tenders received without proof of eligibility criteria will be rejected.**
3. Tender documents can also be obtained by submitting a written request to the Purchase Officer together with prescribed tender fee, provided that the eligibility criteria is fulfilled. Last date for issue of Tender documents is 23-9-2009
4. While requesting for Tender Documents, such request shall indicate **the “REQUEST FOR TENDER DOCUMENTS AGAINST TENDER NOTICE NO.IPR/TN/PUR/027/09-10 DATED 3-9-2009”.**
5. The tender fee of Rs.200/- (non refundable) should be made in the form of **DEMAND DRAFT from any nationalized/scheduled bank drawn in favour of Institute for Plasma Research and payable at Ahmedabad.** Vendor's name and tender number shall be indicated on the reverse side of the Demand Draft.
6. **DD should not be prior dated to the date of advertisement. Separate request letter and separate Demand Draft shall be sent for each tender.**
7. Those who use the downloaded tender documents from IPR Website may submit the prescribed Tender Fee keeping in a separate envelope along with the tender.
8. **Tenders received without the prescribed tender fee will be rejected.**
9. No request for the extension of due date will be considered.
10. Late/Delayed offers will not be accepted.
11. **Tender in a sealed envelope (Technical Bid and commercial terms and conditions Part-A & EMD in one envelope and Price Bid (Part-B) in another envelope) superscribing the envelope with the above tender no., date, due date and brief description of tendered item should be submitted to the Purchase Officer at the above address by 1.00 p.m. on 15<sup>th</sup> October, 2009. Part-A (Technical Bid and**

**commercial terms and conditions along with Tender Fee of Rs.200/- and EMD for Rs.20,000/-) received upto 1.00 p.m. on 15-10-2009 will be opened on the same day at 2.30 p.m. in the presence of attending tenderers.**

12. In the event of any date indicated above is a declared Holiday, the next working day shall become operative for the respective purpose mentioned herein.
13. IPR will not be responsible for any delay/loss of documents in transit.
14. Tenders received without the details asked for including proof of eligibility for participating in the tender may not be considered.
15. Tenderers should furnish/enclose full technical details/literature, delivery period and confirm the terms and conditions attached with the tender.
16. **Those who do not meet with the eligibility criteria need not submit Tender.**
17. **Those who are quoting on behalf of their foreign Principals should submit a Proforma Invoice of Foreign Principals in foreign currency.**
18. The Director, IPR reserves the right to accept or reject any offer in full or part thereof without assigning any reason thereof.
19. **Quotations received without EMD will not be considered.**
20. **The representative who is going to attend the tender opening should carry an authorization letter from the organization for participation in the tender opening failing which he will not be allowed to participate in the tender opening.**

#### **ELIGIBILITY CRITERIA:**

It is preferable that the vendor has made made/supplied similar kind of machines in the past to industries/institutes costing ~ 40 lakhs or more.

**NOTE: Issue of tender documents does not mean that a vendor is qualified to submit tenders. IPR's decision to consider as to whether a vendor has met with the eligibility criteria is final.**

**ANNEXURE– A**

**Manufacture, inspection, testing, supply and there after commissioning of  
CNC Single Spindle 3-Axes Horizontal Gun Drilling Machine  
at BARC, Mumbai**

**Main features**

- Heavy duty bed either made of high grade C.I. or fabricated base made of stress relieved steel
- Single Spindle Gun Drilling unit with motorized spindle.
- Centralized lubrication for all axes and feed screws.
- Spindle with precision angular contact bearings, make is to be specified.
- AC Servo feed slide movements (X, Y and Z slides).
- LM guideways for X, Y and Z axes.
- Telescopic covers for guideways.
- Feed back through built in absolute encoder.
- Carbide gundrill with coolant through tool.
- Guide bush butting arrangement.
- Provision for dialing the job in all X, Y and Z planes.
- SIEMENS 810D/Fanuc OiMD control system.
- Tool Monitoring System with power sensor to detect gun drill wear and breakage.
- Manually operated fixture for component outer dia  $\varnothing 180 \times 320$  mm long &  $\varnothing 100 \times 120$  mm long.
- Filter for effective chip filtration (for ferrous and non-ferrous materials).
- Fully enclosed guards with manually operated door.
- Electrical equip. should be suitable for 3 phase 415 volts, 50 cycles, A.C. supply.
- Electrical control cabinet with built- in air conditioner.
- Standard Machine Lamp.
- High pressure coolant equipment.
- Chip conveyor with chip bin.
- Hand tools and tool box.
- Operation, Programming, Maintenance and Spare parts manual – 3 sets.
- Colour – manufacturer’s standard colour/special colour as per offer.

## Technical Specifications:

### Capacity

|      |                     |   |   |
|------|---------------------|---|---|
| 1.1  | Drilling Diameter   | : | Ø3 to Ø20 mm.   |
| 1.2  | Drilling Depth      | : | 100 mm to 1000 mm.                                    |
| 1..3 | Component Outer Dia | : | Ø 20 mm to Ø 200 mm.                                  |
| 1.4  | Component length    | : | 2000 mm (Max).  |
| 1.5  | Work table size     | : | 500mm x 2000mm<br>Minimum with standard<br>'T' Slots. |
| 1.6  | Max. Load on table  | : | 500 kgs.  |

### Spindle

|     |                 |   |                             |
|-----|-----------------|---|-----------------------------|
| 2.1 | No. of Spindle  | : | 1 No.                       |
| 2.2 | Type of Spindle | : | Integral motorized spindle. |
| 2.3 | Spindle Power   | : | 6 kW.                       |

### Feed

|     |                   |   |   |
|-----|-------------------|---|---|
| 3.1 | Type of feed      | : | AC Servo drive with ball<br>screw and pre loaded nut. |
| 3.2 | Stroke for X-axis | : | 300 mm.   |
| 3.3 | Stroke for Y-axis | : | 250 mm.   |
| 3.4 | Stroke for Z-axis | : | 1000 mm.  |
| 3.5 | Feed range        | : | 1mm/minute to<br>500mm/minute.                        |
| 3.6 | Rapid traverse    | : | 10000 mm/minute.                                      |

### Coolant System

|     |                   |   |  |
|-----|-------------------|---|--|
| 4.1 | Type of coolant   | : | Suitable for Copper &<br>Stainless steel |
| 4.2 | Tank Capacity     | : | 800 liters.                              |
| 4.3 | Delivery Pressure | : | 95 bar (max).                            |
| 4.4 | Coolant delivery  | : | 50 liters per minute.                    |

5. CNC System- Siemens 810 D/ Fanuc OiMD.

|     |                    |   |                            |
|-----|--------------------|---|----------------------------|
| 5.1 | Mode of operations | : | Tool rotating and feeding. |
|-----|--------------------|---|----------------------------|

### 6 Machine accuracies

|     |                                       |   |  |
|-----|---------------------------------------|---|--|
| 6.1 | Spindle run-out in any direction      | : | ≤ 0.005 mm.  |
| 6.2 | Positioning accuracies for X & Y axes | : | ± 0.005 mm/300 mm.                                 |
| 6.3 | Positioning accuracies for Z axis     | : | ± 0.005 mm/300 mm &<br>0.03mm over<br>full length. |
| 6.4 | Repeatability X , Y & Z axes          | : | ≤ 0.005 mm.  |
| 6.5 | Gun Drilling Hole Drift<br>100 mm.    | : | ≤ 0.15 mm over a length of                         |

7 Component

|      |  |   |   |
|------|--|---|---|
| 7.1  | Component type to be proved                                  | : | (i) OFHC Copper Billet as per Sketch-A<br>Dim. before drilling as per Sketch-A1<br>(ii) OFHC Copper Billet as per Sketch-B<br>Dim. before drilling as per Sketch-B1 |
| 8    | Fixture  |   |   |
| 8.1  | Manual fixture for Copper Billet as per Sketch – A           | : | 1 No.   |
| 8.2  | Manual Fixture for Copper as per sketch – B                  | : | 1 No.   |
| 8.3  | Number of component per fixture                              | : | 1.  |
| 9    | Toolings for Copper Billet as per Sketch – A.                |   |   |
| 9.1  | Carbide Gun Drill $\varnothing$ 8.5 mm                       | : | 50 Nos.   |
| 9.2  | Carbide Counter boring tool/ gun reamer $\varnothing$ 9.0 mm | : | 50 Nos.   |
| 9.3  | Gun Drill adaptors   | : | 4 Nos.  |
| 9.4  | Guide Bush $\varnothing$ 8.5 mm gun drill                    | : | 5 Nos.  |
| 9.5  | Guide Bush $\varnothing$ 9 mm gun reamer                     | : | 5 Nos.  |
| 10   | Toolings for Copper Billet as per Sketch – B.                |   |   |
| 10.1 | Carbide Gun Drill $\varnothing$ 4.6 mm                       | : | 50 Nos.   |
| 10.2 | Carbide Counter boring tool/ gun reamer $\varnothing$ 4.9 mm | : | 50 Nos.   |
| 10.3 | Gun Drill adaptors   | : | 4 Nos.  |
| 10.4 | Guide Bush $\varnothing$ 4.6 mm gun drill                    | : | 5 Nos.  |
| 10.5 | Guide Bush $\varnothing$ 4.9 mm gun reamer                   | : | 5 Nos.  |

## 11 Optional accessories

Voltage stabilizer.

Isolation transformer.

Standard Gun drills and guide bushes of sizes  $\varnothing$ 3 mm to  $\varnothing$  20 mm in steps of 1 mm with break up cost. Length of the quoted drills are to be specified.

Gun Drill re-grinding unit (make is to be specified).

- 12 Spares including PCB for further two years smooth operation after warranty period. If spare PCBs are not quoted please quote for full CNC system package along with motor and drive or the basic CNC system with drives only (without motor) as spare. Electronics spares are to be tested on machine. List and price break-up shall be furnished.**

## **ANNEXURE- B**

### **General terms and conditions.**

- 1 Offer shall include the complete cost of manufacture, Inspection, testing, supply at CDM, BARC, Mumbai and thereafter commissioning and guarantee of CNC Single Spindle 3-Axes Horizontal Gun Drilling machine as specified in Annexure-A along with standard, optional and manufacturers' special accessories for the proposed machine, spares for two years smooth operation after warranty period etc. Erection will be undertaken by the purchaser as per details provided by the supplier.
- 2 **The supplier shall furnish the following information along with the quotation**
  - 2.1 Detailed catalogue of the machine and other accessories.
  - 2.2 Cycle time estimate for components as per Sketch – A & B.
  - 2.3 Drawings of foundation details if any.
  - 2.4 Geometrical alignment and practical test chart for the machine offered indicating the guaranteed accuracies.
  - 2.5 The overall size and weight of the machine
  - 2.6 Packing and forwarding charges.
  - 2.7 Supplier should provide complete PLC listing in English along with comments (Hard & soft copy)
  - 2.8 Service manuals along with PCB circuit diag. & complete electrical diag. should be provided
- 3 **Inspection, testing and acceptance at manufacturer's works:**

Machine will be inspected and tested for geometrical accuracies at manufacturer's works and witnessed by our representative as per the test chart issued by the supplier and approved by us. Positioning accuracy and repeatability will be tested as per VDI DGQ 3441 or equivalent by LASER interferometer method and witnessed by our representatives. 3 numbers each of copper billets as per Sketch-A & B have to be successfully machined at supplier's works for which pre-machined materials as per Sketch-A1 & B1 will be provided by the purchaser. The supplier has to provide certified position gauges (pin insertion type) approved by the purchaser, for inspection of hole orientation and drift. The supplier has also to demonstrate drilling of 20mm diameter through holes (drilling from both ends) in 3 sample rods of 30 to 50 mm diameter and 2000 mm long SS/Alloy Steel material for which material is to be arranged by the supplier.
- 4 **Final acceptance at CDM, BARC after commissioning:**
  - 4.1 Geometrical accuracies as per test chart issued by the supplier. Positioning accuracy and repeatability will be tested as per VDI/DGQ 3441 or equivalent test chart by LASER interferometer method.
  - 4.2 Successful drilling of 3 numbers of copper billets as per Sketch-A & B and drilling of 10 mm diameter through holes in 2000 mm long OFHC Copper rods.

- 5 **Training:**  
The supplier shall arrange for training three persons from operation and three persons from maintenance (mechanical and electronics) at their works for one week.
- 6 **Warranty:** 12 months from the date of commissioning of machine at purchaser's works.
- 7 **The supplier shall furnish the list of users for similar machines with date of installation and complete address.**
- 8 **Validity:** 120 days from the date of opening the tender.
- 9 **Police Verification certificate:** Please note that vendor's persons coming for installation and commissioning need to have Police Verification Certificate (PVC), and without this document it will not be possible to allow him to enter in purchaser's premises. The vendor will have to submit to the purchaser PVC of the persons coming for installation and commissioning at the time of pre dispatch inspection. The vendor will have to arrange this document themselves, in advance in the event of placing the purchase order so that installation and commissioning work at purchaser's site is completed in time.

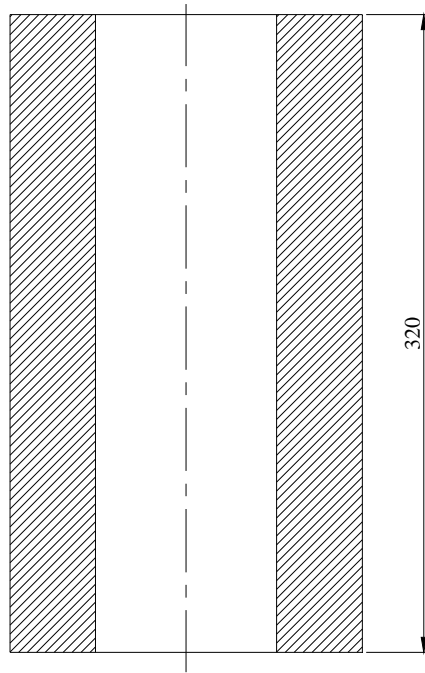
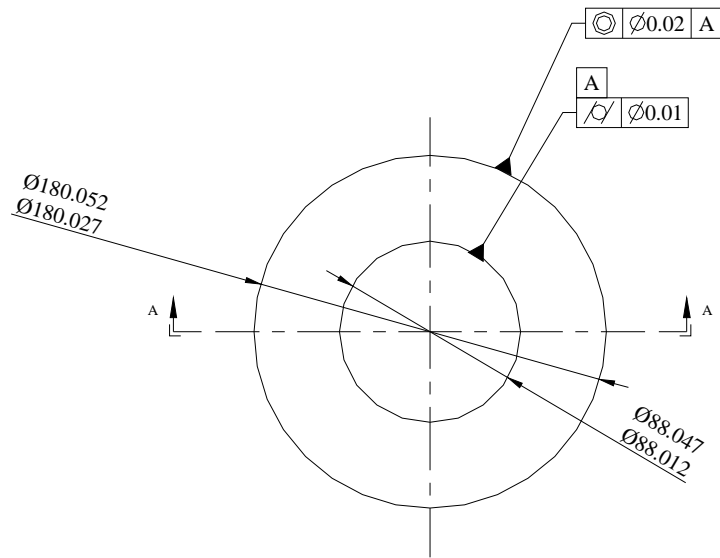

SECTION - 'A - A'

EXTRUSION BILLET  
 STAGE - 1 PRE MACHINED RAW MATERIAL  
 Material - OFHC Copper

SKETCH - A1

All dimensions are in mm.

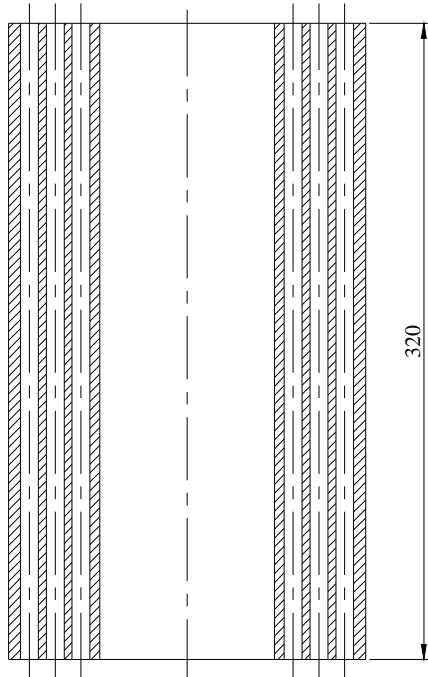
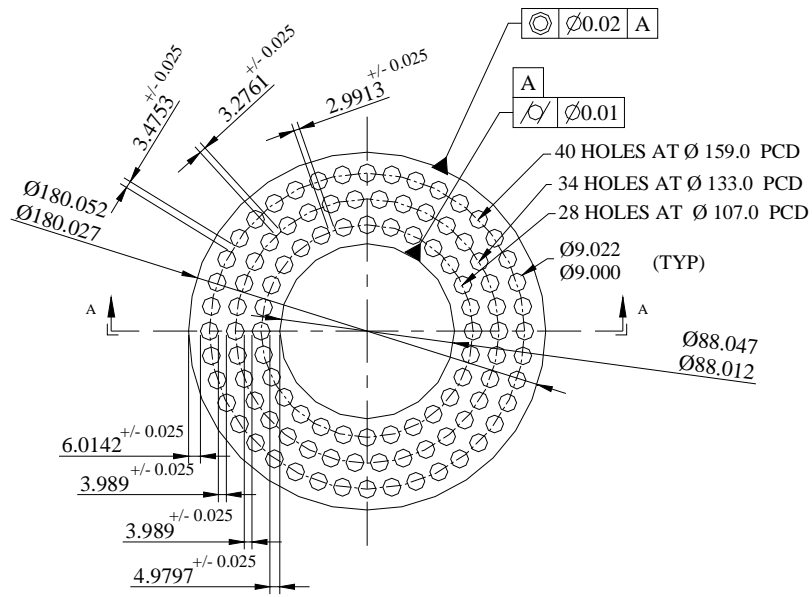

SECTION - 'A - A'

**EXTRUSION BILLET**  
**STAGE - 2 GUN DRILLING**  
 Material - OFHC Copper  
 Surface Finish - 0.8 micron or better for all holes.

**SKETCH - A**

All dimensions are in mm.

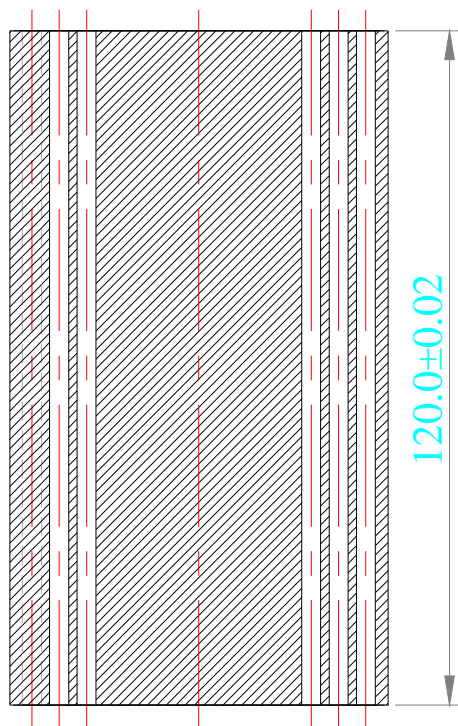
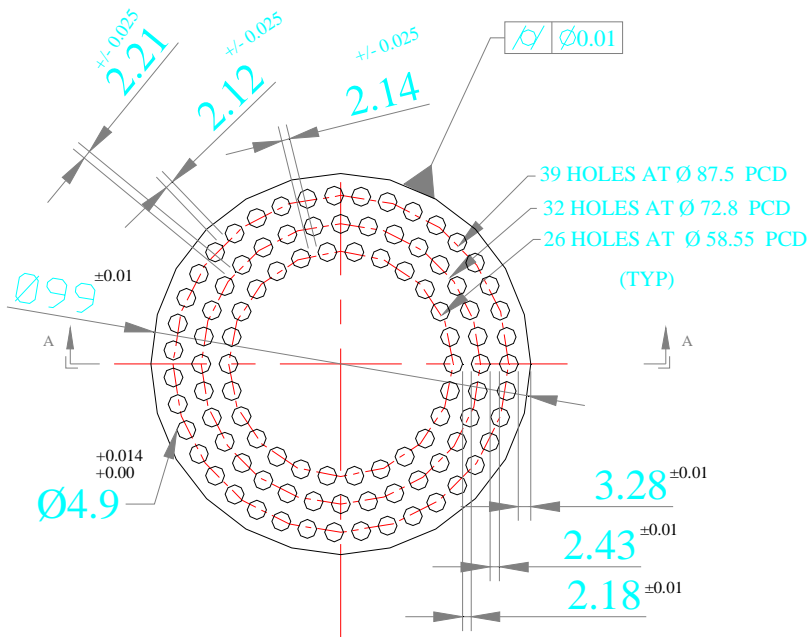

All dimensions are in mm

SKETCH B  
 EXTRUSION BILLET  
 Material - OFHC Copper  
 Surface finish :  $0.8 \mu$  better for all holes

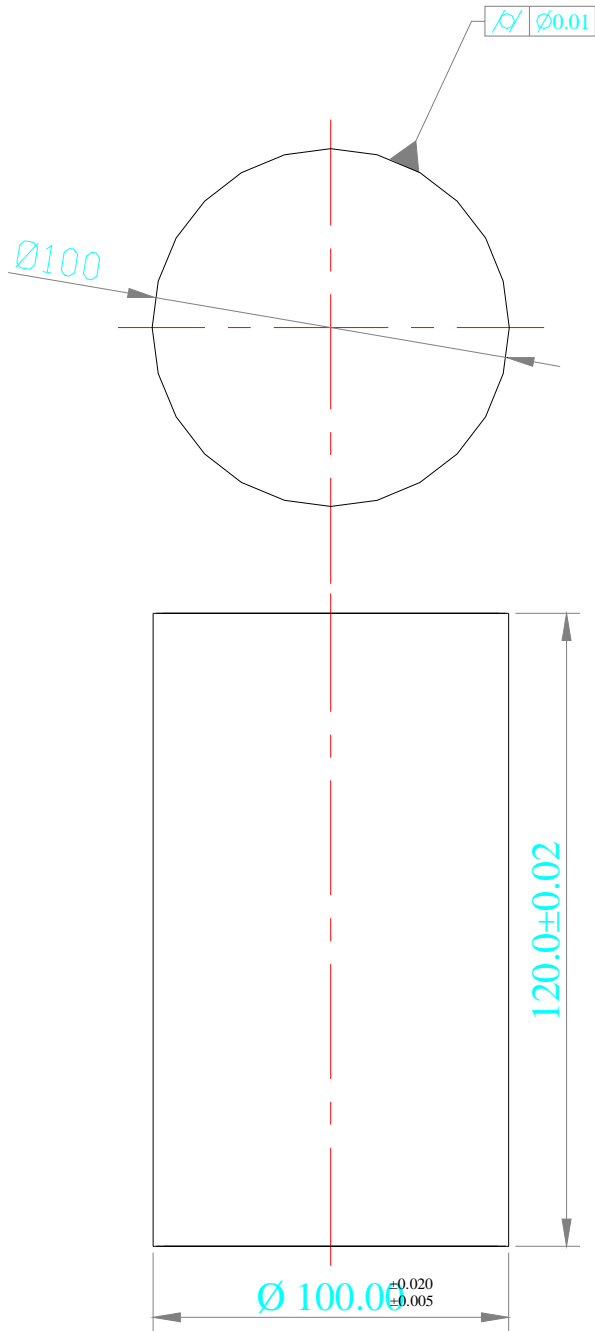

All dimensions are in mm

SKETCH : B1

Material - OFHC Copper

**INSTRUCTIONS TO BIDDERS AND TERMS AND CONDITIONS**

1. The quotation and any order resulting from this tender/enquiry shall be governed by our Conditions of contract and supplier quoting this enquiry shall be deemed to have read and understood the same in toto.
2. Where counter terms and conditions have been offered by the supplier, the same shall not be deemed to have been accepted by us, unless our specific written acceptance thereof is obtained.
3. **Tender Fee: Tenders received without the prescribed Tender Fee will be rejected.**
4. **Clarifications:**  
Any technical and commercial questions, information, clarifications, etc. that may be required pertaining to this Tender/enquiry may be obtained from the Purchaser before submitting the tender.
  - 4.1 Bids shall be complete in all respects and shall include properly filled in prices, other specifications, schedules, relevant drawings and catalogues as necessary alongwith the bid covering letter, all in duplicate.
5. **QUOTATION:**  
Quotation should be submitted **in two parts, i.e. Part-A (Technical Bid, Commercial Terms and conditions, Tender Fee and EMD and Part-B (Price Bid).** Tender should be submitted in two separate sealed envelopes (in duplicate) superscribing the above tender no., date, due date and brief description of tendered item along with Earnest Money Deposit (EMD) for Rs.20,000/- by way of Demand Draft from a nationalized/scheduled drawn in favour of ***Institute for Plasma Research*** and payable at Ahmedabad should be submitted to the Purchase Officer at the above address latest by 1.00 p.m. on **15-10-2009.** **Part-A (Technical Bid along with Tender Fee of Rs.200/-, commercial terms and conditions and EMD for Rs.20,000/-)** will be opened on the same day at 2.30 p.m. in the presence of attending tenderers.
  - 5.1 Late and delayed quotations will not be considered. IPR will not be responsible for postal delays or any other delays in receipt of quotation. Envelopes received without Tender number, date, due date and short description of item may be rejected. The quoted prices should be firm for a period of 120 days from due date for placing order. IPR is not bound to accept lowest rate/s. IPR reserves the right to place order on one or more parties irrespective of whether he is lowest or not. The scope of supply includes insurance by the Contractor/Supplier.
6. **Specifications:** Material should be offered strictly conforming to our specifications/drawings. Deviation, if any, should be clearly indicated by the supplier in their quotation. The supplier should also indicate the Make/Type number of the materials offered and catalogues, technical literature and samples, wherever necessary should accompany the quotation.
7. **Terms of prices:** Quotation should be submitted on door delivery basis without extra charge wherever possible. For quotations on Ex-Works, Ex-godown basis

the approximate packing and forwarding charges should be indicated by the supplier. In the case of local suppliers, the material is to be delivered at our stores free of charge. Unit rate/s should be valid throughout the validity of purchase order/contract period for addition/deletion purposes. Break-up of price should be furnished. The quoted price should not be subject to price escalation for whatsoever reasons. The quoted price shall be firm, fixed and non-revisable during the validity/extended validity of purchase order/contract.

- 7.1 Prices are required to be quoted according to the units indicated in the tender form. When quotations are given in terms of units other than those specified in the tender form, relationship between the two sets of units must be furnished.
- 7.2 Wherever options are specified in the tender documents, IPR reserves the right to accept any option/s irrespective of whether all the vendors have quoted for all the options or not. The decision of IPR in this regard will be final.
8. Tender should be free from Correction and Erasures. Corrections, if any, must be attested. All amounts shall be indicated both in words as well as in figures. Where there is difference between amounts quoted in words and figures, amount quoted in words shall prevail.
9. IPR shall be under no obligation to accept the lowest or any tender and reserves the right of acceptance of the whole or any part of the tender or portion of the quantity offered and the tenderers shall supply the same at the rates quoted.
10. **Sales Tax etc.:** We have no "C" or "D" form. The percentage of Sales Tax/VAT, surcharge, if applicable, and other levies legally leviable and intended to be claimed should be clearly indicated in the tender. Where this is not done, no claim on these accounts would be admissible later.
- 10.1 **VAT Registration:** You may submit a copy of VAT Registration certificate along with your quotation (if applicable).
- 10.2. **Service Tax:** Wherever Service tax is applicable, it should be mentioned clearly. You may indicate percentage of Service Tax in your quotation.
- 10.3 **Excise Duty:** As per Notification No.10/97-CE (Central Excise) dated 1-3-1997, the Purchaser is entitled for availing Excise Duty exemption at present. Excise Duty Exemption Certificate, wherever applicable, and as per rules will be issued at the appropriate time. Hence Excise Duty should not be included in the BID. However, prevailing percentage of Excise Duty may be indicated.
- 10.4 **Octroi:** Octroi is not applicable in our case.
11. **Delivery Date:** The supplier must indicate the firm delivery date by which the materials will be despatched/delivered by them from the date of our order.
12. **Inspection:** Materials on its arrival at IPR will be inspected by Stores In-charge, and his decision in the matter will be final.
13. **EARNEST MONEY DEPOSIT (EMD):**  
The Bidder shall submit interest free Earnest Money Deposit (EMD) for Rs.20,000/- (Rupees Twenty thousand only) by way of Demand Draft from a nationalized/scheduled bank issued in favour of ***"Institute for Plasma Research"***

and payable at **Ahmedabad**. Tender received without EMD will be rejected at the discretion of IPR.

14.1 **EMD of unsuccessful Bidder will be returned after finalizing the Contract/placing Purchase order.**

14.2 **The EMD shall be forfeited in case the selected Bidder does not start the work within the time limit specified or fail to complete the work within the stipulated delivery period or fail to comply with any of the terms and conditions in the purchase order/contract.**

15. **Payment:**

15.1 10% advance against submission of Bank Guarantee for an equivalent amount from a nationalized/scheduled commercial Bank. This payment will be made only after signing the contract/Purchase order and submission of Security Deposit.

15.2 10% after approval of major drawings by IPR and on receipt of Bank Guarantee for an equivalent amount from a nationalized/scheduled commercial bank.

15.3 60% against delivery of material at BARC, Mumbai site, its verification by IPR/BARC representative and on receipt of Proforma Invoice in triplicate.

15.4. 20% within 30 days from the date of final acceptance and on receipt of Performance Bank guarantee for 10% of the contract value from a nationalized/scheduled commercial bank.

Wherever, advance payment is involved, it will be paid only against submission of Bank Guarantee from a Nationalised Bank. Bank Guarantees should be furnished as per IPR format.

16. No correspondence will be entertained within 30 days from the date of receipt of material and bills, whichever is later.

17. Quotation should be valid at least for 120 days from the date of opening of the tender.

18. **Guarantee:** The Stores/material/goods/equipment offered by the bidder should be guaranteed for a minimum period of twelve months, against defective materials, design, workmanship, operation or manufacture. For defects noticed during the Guarantee period, replacement/ rectification should be arranged free of cost within a reasonable period of such notification. In cases where our specifications call for a guarantee period more than 12 months specifically, then such a period shall apply.

19. **Security Deposit:** The successful Bidder will have to furnish to the Purchaser an interest free security deposit for 10% (Ten percent) of the order value in the form of Bank Guarantee of an equivalent amount from a nationalised/scheduled commercial Bank within 15 days from the date of LOI/Purchase order and the said Guarantee should be valid till the goods are accepted by IPR. The Security deposit shall be forfeited in case the selected Bidder does not start the work within the time limit specified or fail to complete the work within the stipulated delivery period or fail to comply with any of the terms and conditions in the purchase order/contract.

20. **Liquidated Damages:** In addition to forfeiting Security Deposit, Liquidated Damages for the delay shall be 1/2% (half percent) of the total order value for the

delay of each week in the scheduled time of supply or the scheduled date of final completion for the work as the case may be, subject to a maximum of 5% (five percent) of total order value. Liquidated Damages will be recovered from the payment due to the supplier.

21. **Performance Bank Guarantee:** The Contractor/Supplier will have to furnish to the Purchaser (IPR) an interest free performance bank guarantee for 10% (Ten percent) of the order value/ contract value by Demand Draft or by way of providing a Bank Guarantee from a Nationalised/Scheduled commercial Bank valid for a period of 12 months/guarantee period mentioned in the order from the date of installation/acceptance for satisfactory performance of the work carried out by the Contractor.
22. The Contractor/Supplier shall at all times indemnify the purchaser against all claims which may be made in respect of the stores/material/goods/equipment for infringement of any right protected by Patent Registration of design or Trade Mark and shall take all risk of accidents or damage, which may cause failure of supply from whatever cause arising and the entire responsibility for sufficiency of all means used by him for the fulfillment of the contract.
23. **BAR/PERT Charts:**  
To be provided as per the requirement of Purchaser.
24. **Sub-Contract:** All sub-contractors are required to be appraised and approved by the Purchaser before placement of orders by the Vendor.
25. **Jurisdiction:** The contract/Purchase order shall be governed by the Laws of India for the time being in force. The Courts of Ahmedabad only shall have jurisdiction to deal with and decide any legal or dispute arising out of this contract.
26. **Settlement of disputes:** Any disputes or difference arising out of or in connection with the Contract/Purchase order shall be to the extent possible settled amicably between the parties.  
  
If amicable settlement cannot be reached then all disputed issues shall be settled by arbitration.
27. **Arbitration:** In the event of any dispute or difference arising under this Contract, the matter shall be referred to the Arbitrators one each nominated by the Purchaser and Contractor from their respective organisations. In case the said Arbitrators are not able to settle the dispute by themselves, the matter shall be referred to the Arbitrator mutually nominated by the Purchaser and the Contractor and whose decision will be final and binding on both the parties. The venue of arbitration will be IPR. Subject to as aforesaid the Arbitration Act, 1940 and the rules thereunder and any statutory modification thereof for the time being in force shall be deemed to apply to the Arbitration proceedings under this Contract.
28. **Permits and Licences:** The Contractor shall secure and pay for all permits and licence which he may require to comply with in respect of all laws, ordinances and regulations of the Government or Public Authorities in connection with the performance of his obligations under the Contract. The successful contractor shall be responsible for all damages and shall indemnify and save the Purchaser harmless from and against all claims for damages and liability which may arise due to his failure to comply with what is stated above.

29. **Training:** The successful tenderer shall, if required by the Purchaser, provide facilities for the practical training of Purchaser's engineering or technical personnel for their active association on the manufacturing process throughout the manufacturing period of the Contract/stores, number of such personnel to be mutually agreed upon.
30. **Operation/Instruction Manual:** Where operation/instruction manual is essential to enable the Purchaser to put the stores to proper use, the successful tenderer shall furnish such operation/instruction manual along with the stores.
31. **Test Certificate:** Wherever required, test certificates should be sent along with the despatch documents.
32. **Secrecy:**
- 32.1 All information, drawings, designs and specifications imparted to the bidder/successful contractor shall, at all times, remain the absolute property of the Purchaser, the bidder/successful contractor shall not use them for purposes other than for which they are provided for and shall treat all these documents as confidential. These shall not be reproduced in whole or in part for any other purpose.
- 32.2 The contractor shall use his best endeavours to ensure that such information are not divulged to third parties except where needed for the performance of the contract by the successful bidder with the prior consent of the Purchaser. In such cases, the successful contractor shall ensure and obtain similar obligation of confidence, from third parties in question.
33. **Indemnity:** The Contractor shall warrant and be deemed to have warranted that all stores supplied against this contract are free and clean of infringement of any Patent, copy right or trade mark and shall at all times indemnify the Purchaser against all claims which may be made in respect of the stores for infringement of any right protected by patent. Registration of design or Trade Mark and shall all risk of accidents of damage which may cause a failure of the supply from whatever cause arising and the entire responsibility for the sufficiency of all the means used by him for the fulfilment of the contract.
34. **Counter terms and conditions of Suppliers:** Where counter terms and conditions printed or cyclostyled conditions have been offered by the supplier, the same shall not be deemed to have been accepted by the Purchaser unless specific written acceptance thereof is obtained.
35. **Installation/commissioning/site works:** Wherever these activities are part of scope of work/specifications, Vendor should carryout out the same without any extra cost to IPR.
36. **Free Issue Material (FIM) (If specified in the tender documents):** Successful tenderer will have to furnish in the form a Bank Guarantee or in any other form as called for by the Purchaser towards adequate security for the materials/property provided/issued by the Purchaser as Free Issue Material (FIM) for the due execution

of the contract. Successful bidder shall submit Bank Guarantee from a nationalized bank and arrange insurance for the cost of FIM at his expenses.

37. Late/delayed tenders will not be accepted. Incomplete tenders may be rejected at the discretion of IPR.
38. **IPR is not bound to accept the lowest tender. IPR reserves the right to select any vendor at its sole discretion.**
39. **Result of the tenders:** Unsuccessful tenderers will not be informed of the result of their tenders.
40. The Director, IPR reserves the right to accept or reject any quotation/tenders fully or partly without assigning any reason.
41. IPR reserves the right to place order on a single party or to split the order at its sole discretion.

**We agree to the above terms and conditions.**

**Place:**

**Signature of Bidder with seal**

**Date:**

**Note: A copy of our terms and conditions duly signed should accompany your quotation.**

## PART-B

### PRICE BID FORMAT

*(Bidders are requested to offer their price bid in the following format)*

| S.No             | Description   | Quantity | Unit cost (Rs.) | Total price (Rs.) |
|------------------|---|----------|-----------------|-------------------|
| 1                | Design, fabrication, factory testing and supply at BARC site of the three axes Gun Drilling machine as mentioned in the tender specifications | 1 No.    |                 |                   |
| 2.               | Installation and commissioning charges (including unloading, shifting, handling with accessories)<br><b>(Quote Lumpsum charge)</b>            | Lumpsum  |                 |                   |
| 3.               | Other charges, if any.  |          |                 |                   |
| <b>Total Rs.</b> |   |          |                 |                   |

|                              | <u>Indicate percentage except Freight</u> |          |          |
|------------------------------|---|----------|----------|
|                              | Percentage                                | Included | Excluded |
| Packing and forwarding       |   |          |          |
| Excise Duty                  |   |          |          |
| Sales Tax/VAT                |   |          |          |
| Insurance                    |   |          |          |
| Service Tax on Sr.No.2 above |   |          |          |
| Freight                      | Rs.                                       |          |          |

**Place:**

**Signature of Bidder with seal**

**Date :**