

INSTITUTE FOR PLASMA RESEARCH
NEAR INDIRA BRIDGE, BHAT, GANDHINAGAR 382 428
GUJARAT STATE
Phone: 079 23962021, 23962023 Fax: 079 23962277

TENDER NOTICE DATED 17-11-2009

Itemwise sealed tenders are invited from reputed and eligible parties for the following.

Sr. No	Tender Notice No.	Item	Quantity	Due Date & time of opening	Tender Fee (Rs.)	EMD (Rs.)
1.	IPR/TN/PUR/030/09-10	1. ASTM A 387 Gr91 Steel Plate 6mm thick 2. ASTM A 387 Gr91 Steel Plate 5mm thick	150 Kgs. 125 Kgs.	17-12-2009 2.30 p.m.	200.00	10000.00
2.	IPR/TN/PUR/031/09-10	Supply, erection, installation and commissioning of Rotary Screw Air Compressor. Pressure rating: 10 bar (G)	1 No.	23-12-2009 2.30 p.m.	200.00	10000.00
3.	IPR/TN/PUR/032/09-10	Supply, erection, installation and commissioning of Reciprocating Air Compressor unit	1 No.	23-12-2009 3.30 p.m.	100.00	5000.00
4.	IPR/TN/PUR/033/09-10	DC Coil Power supply of 0 to 40V, 125 Amp.	1 No.	31-12-2009 2.30 p.m.	200.00	5000.00
5.	IPR/TN/PUR/034/09-10	Design, fabrication, factory testing, installation, commissioning and testing at site of Integrated Power Supply on turnkey basis	1 No.	31-12-2009 3.30 p.m.	200.00	15000.00

Tender documents are available on IPR Website : www.ipr.res.in/purchasetenders.html. Tenderers meeting the eligibility criteria mentioned in the tender documents may, at their option, download the tender documents from the website and submit their offer along with prescribed **Tender Fee (non refundable) and EMD** in the form of Demand Draft from any nationalized/scheduled bank drawn in favour of **Institute for Plasma Research** and payable at **Ahmedabad** as per the details given in the tender documents. In case party desires to collect the tender documents by post, they may contact the Purchase Officer along with prescribed tender fee. Tender documents will be issued upto **11-12-2009** representative who is going to attend the tender opening should carry an authorization letter from the organization for participation in the tender opening failing which he will not be allowed to attend the tender opening.

TENDER NOTICE No.IPR/TN/PUR/034/09-10 DATED 17-11-2009

For Design, fabrication, factory testing, installation, commissioning at site of Integrated Power Supply on turnkey basis – 1 No.

NOTE:

1. Full details and specifications of the items and general instructions to be followed regarding submission of tenders are indicated in the tender documents.
2. **Proof for fulfillment of eligibility criteria mentioned hereunder should be submitted along with the tender. If the tender is submitted without valid documents, we shall not consider your offer. Tenders received without proof of eligibility criteria will be rejected.**
3. Tender documents can also be obtained by submitting a written request to the Purchase Officer together with prescribed tender fee, provided that the eligibility criteria is fulfilled. Last date for issue of Tender documents is 11-12-2009
4. While requesting for Tender Documents, such request shall indicate the **“REQUEST FOR TENDER DOCUMENTS AGAINST TENDER NOTICE NO.IPR/TN/PUR/034/09-10 DATED 17-11-2009”.**
5. The tender fee of Rs.200/- (non refundable) should be made in the form of **DEMAND DRAFT from any nationalized/scheduled bank drawn in favour of Institute for Plasma Research and payable at Ahmedabad.** Vendor's name and tender number shall be indicated on the reverse side of the Demand Draft.
6. **DD should not be prior dated to the date of advertisement. Separate request letter and separate Demand Draft shall be sent for each tender.**
7. Those who use the downloaded tender documents from IPR Website may submit the prescribed Tender Fee keeping in a separate envelope along with the tender.
8. **Tenders received without the prescribed tender fee will be rejected.**
9. No request for the extension of due date will be considered.
10. Late/Delayed offers will not be accepted.
11. Tenders in a sealed envelope superscribing the envelope with the above tender no., date, due date and brief description of tendered item along with EMD for Rs.15,000/- by way of Demand Draft from a nationalized/scheduled bank drawn in favour of **Institute for Plasma Research** and payable at **Ahmedabad** should be submitted to the *Purchase Officer* at the above address by 1.00 p.m. on **31st December, 2009.** Tenders received upto 1.00 p.m. on 31-12-2009 will be opened on the same day at **3.30 p.m.** in the presence of attending tenderers.

12. In the event of any date indicated above is a declared Holiday, the next working day shall become operative for the respective purpose mentioned herein.
13. IPR will not be responsible for any delay/loss of documents in transit.
14. Tenders received without the details asked for including proof of eligibility for participating in the tender may not be considered.
15. Tenderers should furnish/enclose full technical details/literature, delivery period and confirm the terms and conditions attached with the tender.
16. **Those who do not meet with the eligibility criteria need not submit Tender.**
17. **Those who are quoting on behalf of their foreign Principals should submit a Proforma Invoice of Foreign Principals in foreign currency.**
18. The Director, IPR reserves the right to accept or reject any offer in full or part thereof without assigning any reason thereof.
19. **Quotations received without EMD will not be considered.**
20. **The representative who is going to attend the tender opening should carry an authorization letter from the organization for participation in the tender opening failing which he will not be allowed to participate in the tender opening.**

ELIGIBILITY CRITERIA: The vendor (i) must be a manufacturer or authorized dealer/distributor (in case of authorized dealer/distributor, attach valid dealership/distributorship certificate); (ii) must have supplied regulated power supply or drives of output rating 6kV or higher (attach copy of purchase order) and (ii) must have proven experience in supplying Programmable Logic Controllers (PLC) based automated control power supply or any other systems (Proof for the above should be submitted with the tender).

NOTE: Issue of tender documents does not mean that a vendor is qualified to submit tenders. IPR's decision to consider as to whether a vendor has met with the eligibility criteria is final.

INSTRUCTIONS TO BIDDERS AND TERMS AND CONDITIONS

1. The quotation and any order resulting from this tender/enquiry shall be governed by our Conditions of contract and supplier quoting this tender shall be deemed to have read and understood the same in toto.
2. Where counter terms and conditions have been offered by the supplier, the same shall not be deemed to have been accepted by us, unless our specific written acceptance thereof is obtained.
3. **Tender Fee:** Tenders received without the prescribed Tender Fee will be rejected.

4. **Clarifications:** Any technical and commercial questions, information, clarifications, etc. that may be required pertaining to this Tender/enquiry may be obtained from the Purchaser before submitting the tender.
- 4.1 Bids shall be complete in all respects and shall include properly filled in prices, other specifications, schedules, relevant drawings and catalogues as necessary alongwith the bid covering letter, all in duplicate.
5. **Quotation:** Your quotation superscribing our tender/enquiry No., date, due date and short description of item should be submitted to the Purchase Officer, IPR in a sealed envelope on or before the due date. Late and delayed quotations will not be considered. IPR will not be responsible for postal delays or any other delays in receipt of quotation. Envelopes received without Tender number, date, due date and short description of item may be rejected. The quoted prices should be firm for a period of 120 days from due date for placing order. IPR is not bound to accept lowest rate/s. IPR reserves the right to place order on one or more parties irrespective of whether he is lowest or not. The scope of supply includes insurance by the Contractor/Supplier.
6. **Specifications:** Material should be offered strictly conforming to our specifications/drawings. Deviation, if any, should be clearly indicated by the supplier in their quotation. The supplier should also indicate the Make/Type number of the materials offered and catalogues, technical literature and samples, wherever necessary should accompany the quotation.
7. **Terms of prices:** Quotation should be submitted on door delivery basis without extra charge wherever possible. For quotations on Ex-Works, Ex-godown basis the approximate packing and forwarding charges should be indicated by the supplier. In the case of local suppliers, the material is to be delivered at our stores free of charge. Unit rate/s should be valid throughout the validity of purchase order/contract period for addition/deletion purposes. Break-up of price should be furnished. The quoted price should not be subject to price escalation for whatsoever reasons. The quoted price shall be firm, fixed and non-revisable during the validity/extended validity of purchase order/contract.
- 7.1 Prices are required to be quoted according to the units indicated in the tender form. When quotations are given in terms of units other than those specified in the tender form, relationship between the two sets of units must be furnished.
- 7.2 Wherever options are specified in the tender documents, IPR reserves the right to accept any option/s irrespective of whether all the vendors have quoted for all the options or not. The decision of IPR in this regard will be final.
8. Tender should be free from Correction and Erasures. Corrections, if any, must be attested. All amounts shall be indicated both in words as well as in figures. Where there is difference between amounts quoted in words and figures, amount quoted in words shall prevail.
9. IPR shall be under no obligation to accept the lowest or any tender and reserves the right of acceptance of the whole or any part of the tender or portion of the quantity offered and the tenderers shall supply the same at the rates quoted.

10. **Sales Tax etc.:** We have no "C" or "D" form. The percentage of Sales Tax/VAT, surcharge, if applicable, and other levies legally leviable and intended to be claimed should be clearly indicated in the tender. Where this is not done, no claim on these accounts would be admissible later.
- 10.1 **VAT Registration:** You may submit a copy of VAT Registration certificate along with your quotation (if applicable).
- 10.2. **Service Tax:** Wherever Service tax is applicable, it should be mentioned clearly. You may indicate percentage of Service Tax in your quotation.
- 10.3 **Excise Duty:** As per Notification No.10/97-CE (Central Excise) dated 1-3-1997, the Purchaser is entitled for availing Excise Duty exemption at present. Excise Duty Exemption Certificate, wherever applicable, and as per rules will be issued at the appropriate time. Hence Excise Duty should not be included in the BID. However, prevailing percentage of Excise Duty may be indicated.
- 10.4 **Octroi:** Octroi is not applicable in our case.
11. **Delivery Date:** The supplier must indicate the firm delivery date by which the materials will be despatched/delivered by them from the date of our order.
12. **Inspection:** Materials on its arrival at IPR will be inspected by Stores In-charge, and his decision in the matter will be final.
13. **Earnest Money Deposit (EMD):** Tenderer should furnish EMD for Rs.15,000/- (Rupees Fifteen thousand only) by way of Demand Draft from a nationalized/scheduled bank drawn in favour of *Institute for Plasma Research* and payable at *Ahmedabad* should be submitted along with quotation. Tender received without EMD will not be accepted.
- 13.1 **EMD of unsuccessful Bidder will be returned after finalizing the Contract/placing Purchase order.**
- 13.2 **The EMD shall be forfeited in case the selected Bidder does not start the work within the time limit specified or fail to complete the work within the stipulated delivery period or fail to comply with any of the terms and conditions in the purchase order/contract.**
14. **Payment:** Within 30 days from the date of acceptance. Wherever, advance payment is involved, it will be paid only against Bank Guarantee from Nationalised/Scheduled Bank.
15. No correspondence will be entertained within 30 days from the date of receipt of material and bills, whichever is later.
16. Quotation should be valid at least for 120 days from the date of opening of the tender.
17. Delivery periods be clearly indicated against each item separately.
18. **Guarantee:** The Stores/material/goods/equipment offered by the bidder should be guaranteed for a minimum period of twelve months, against defective materials, design, workmanship, operation or manufacture. For defects noticed during the Guarantee period, replacement/ rectification should be arranged free of cost within a reasonable period of such notification. In cases where our specifications call for a guarantee period more than 12 months specifically, then such a period shall apply.

19. **Security Deposit:** The successful Bidder will have to furnish to the Purchaser an interest free security deposit for 10% (Ten percent) of the order value in the form of Bank Guarantee of an equivalent amount from a nationalised/scheduled Bank within 15 days from the date of LOI/Purchase order and the said Guarantee should be valid till the goods are accepted by IPR. The Security deposit shall be forfeited in case the selected Bidder does not start the work within the time limit specified or fail to complete the work within the stipulated delivery period or fail to comply with any of the terms and conditions in the purchase order/contract.
20. **Liquidated Damages:** In addition to forfeiting Security Deposit, Liquidated Damages for the delay shall be 1/2% (half percent) of the total order value for the delay of each week in the scheduled time of supply or the scheduled date of final completion for the work as the case may be, subject to a maximum of 5% (five percent) of total order value. Liquidated Damages will be recovered from the payment due to the supplier.
21. **Performance Bank Guarantee:** The Contractor/Supplier will have to furnish to the Purchaser (IPR) an interest free performance bank guarantee for 10% (Ten percent) of the order value/ contract value by Demand Draft or by way of providing a Bank Guarantee from a Nationalised/Scheduled Bank valid for a period of 12 months/guarantee period mentioned in the order from the date of installation/acceptance for satisfactory performance of the work carried out by the Contractor.
22. The Contractor/Supplier shall at all times indemnify the purchaser against all claims which may be made in respect of the stores/material/goods/equipment for infringement of any right protected by Patent Registration of design or Trade Mark and shall take all risk of accidents or damage, which may cause failure of supply from whatever cause arising and the entire responsibility for sufficiency of all means used by him for the fulfillment of the contract.
23. **BAR/PERT Charts:**
To be provided as per the requirement of Purchaser.
24. **Sub-Contract:** All sub-contractors are required to be appraised and approved by the Purchaser before placement of orders by the Vendor.
25. **Jurisdiction:** The contract/Purchase order shall be governed by the Laws of India for the time being in force. The Courts of Ahmedabad only shall have jurisdiction to deal with and decide any legal or dispute arising out of this contract.
26. **Settlement of disputes:** Any disputes or difference arising out of or in connection with the Contract/Purchase order shall be to the extent possible settled amicably between the parties.

If amicable settlement cannot be reached then all disputed issues shall be settled by arbitration.
27. **Arbitration:** In the event of any dispute or difference arising under this Contract, the matter shall be referred to the Arbitrators one each nominated by the Purchaser and Contractor from their respective organisations. In case the said Arbitrators are not able to settle the dispute by themselves, the matter shall be referred to the Arbitrator mutually nominated by the Purchaser and the Contractor and whose decision will be final and binding on both the parties. The venue of arbitration will be IPR.

Subject to as aforesaid the Arbitration Act, 1940 and the rules thereunder and any statutory modification thereof for the time being in force shall be deemed to apply to the Arbitration proceedings under this Contract.

28. **Permits and Licences:** The Contractor shall secure and pay for all permits and licence which he may require to comply with in respect of all laws, ordinances and regulations of the Government or Public Authorities in connection with the performance of his obligations under the Contract. The successful contractor shall be responsible for all damages and shall indemnify and save the Purchaser harmless from and against all claims for damages and liability which may arise due to his failure to comply with what is stated above.
29. **Training:** The successful tenderer shall, if required by the Purchaser, provide facilities for the practical training of Purchaser's engineering or technical personnel for their active association on the manufacturing process throughout the manufacturing period of the Contract/stores, number of such personnel to be mutually agreed upon.
30. **Operation/Instruction Manual:** Where operation/instruction manual is essential to enable the Purchaser to put the stores to proper use, the successful tenderer shall furnish such operation/instruction manual along with the stores.
31. **Test Certificate:** Wherever required, test certificates should be sent along with the despatch documents.
32. **Secrecy:**
 - 32.1 All information, drawings, designs and specifications imparted to the bidder/successful contractor shall, at all times, remain the absolute property of the Purchaser, the bidder/successful contractor shall not use them for purposes other than for which they are provided for and shall treat all these documents as confidential. These shall not be reproduced in whole or in part for any other purpose.
 - 32.2 The contractor shall use his best endeavours to ensure that such information are not divulged to third parties except where needed for the performance of the contract by the successful bidder with the prior consent of the Purchaser. In such cases, the successful contractor shall ensure and obtain similar obligation of confidence, from third parties in question.
33. **Indemnity:** The Contractor shall warrant and be deemed to have warranted that all stores supplied against this contract are free and clean of infringement of any Patent, copy right or trade mark and shall at all times indemnify the Purchaser against all claims which may be made in respect of the stores for infringement of any right protected by patent. Registration of design or Trade Mark and shall all risk of accidents of damage which may cause a failure of the supply from whatever cause arising and the entire responsibility for the sufficiency of all the means used by him for the fulfilment of the contract.
34. **Counter terms and conditions of Suppliers:** Where counter terms and conditions printed or cyclostyled conditions have been offered by the supplier, the same shall not be deemed to have been accepted by the Purchaser unless specific written acceptance thereof is obtained.

35. **Installation/commissioning/site works:** Wherever these activities are part of scope of work/specifications, Vendor should carryout out the same without any extra cost to IPR.
36. **Free Issue Material (FIM) (If specified in the tender documents):** Successful tenderer will have to furnish in the form a Bank Guarantee or in any other form as called for by the Purchaser towards adequate security for the materials/property provided/issued by the Purchaser as Free Issue Material (FIM) for the due execution of the contract. Successful bidder shall submit Bank Guarantee from a nationalized bank and arrange insurance for the cost of FIM at his expenses.
37. Late/delayed tenders will not be accepted. Incomplete tenders may be rejected at the discretion of IPR.
38. **IPR is not bound to accept the lowest tender. IPR reserves the right to select any vendor at its sole discretion.**
39. **Result of the tenders:** Unsuccessful tenderers will not be informed of the result of their tenders.
40. The Director, IPR reserves the right to accept or reject any quotation/tenders fully or partly without assigning any reason.
41. IPR reserves the right to place order on a single party or to split the order at its sole discretion.

We agree to the above terms and conditions.

Place:

Signature of Bidder with seal

Date:

Note: A copy of our terms and conditions duly signed should accompany your quotation.

Specification

Design, Fabrication, Factory testing, Installation, Commissioning & Testing at site of One Integrated Power Supply on turnkey basis. The Integrated Power Supply consists of a HVDC (High Voltage DC) Power Supply and one LVAC (Low Voltage AC) Power Supply with typical output ratings as mentioned below.

S.No.	POWER SUPPLY	RATING	QUANTITY
1.	HVDC Power Supply (HVPS)	10kV DC, 7Amp	1Unit
2.	LVAC Power Supply (LVPS)	12V AC, 120Amp	1Unit

Both of the individual power supplies are PLC controlled and interconnected in a specific configuration for operation. The HVDC power supply shall be floating at a specified voltage. Negative terminal of the HVDC power supply will be grounded through a resistance within the integrated supply. The load will be placed within 10meters of the integrated supply. The details are provided in the general specifications.

A. SCOPE OF BIDDER

- (1) All the attached data sheets must be filled and attached with the quotation. The quotations without filled in data sheets may summarily be rejected.
- (2) Design, Fabrication, Factory testing, Installation, Commissioning & Testing at site of the Integrated Power Supply (Qty. 1No) on turnkey basis.
- (3) Quote for additional cable per meter in case of main input at IPR is available farther away than 10m.

B. SCOPE OF PURCHASER (IPR)

Mains input (3 ϕ , Neutral, Safety Ground & Power Ground) within IPR available at ~10m of the Integrated Power Supply. Dummy / Actual load for the individual power supplies is within 10m of the Integrated Power Supply at IPR.

1. SPECIFICATIONS

A. GENERAL SPECIFICATION

The Integrated Power Supply for indoor operation will be constituted with a HVDC (High Voltage DC) Power Supply and one LVAC (Low Voltage AC) Power Supply. The power transformers and rectifiers are needed to be dry type. Suitable compensation techniques must be used with Rectifier Array that uses the least possible number of elements in series with sufficient current rating to accommodate crowbar current also. The HVDC power supply must limit the arc fault energy to ≤ 50 Joules so that to pass the wire-burn test as described in later sections. A typical block diagram of the Integrated Power Supply is shown in Figure 1.

Output flexible cables of copper conductor and shield (if applicable) must be provided as mentioned in the individual supply specifications. All the performance requirements are needed at load end of output cable. The load would be located within 10m of the Integrated Power Supply.

Mains input of $415V \pm 10\%$; 3 ϕ ; Neutral, Safety Ground, 50Hz, 120kVA will be provided by IPR at a single point within 10m from the Integrated Power Supply. The bidder should provide the additional utility power connections of 230V, 2 Nos. each of 5 & 15A Sockets. All enclosures, cable shields, cable armors and power transformer cores etc of the Integrated Power Supply must be connected to Safety Ground. Integrated Power Supply housing of W 2000 X D 1200 X H 2400mm (Change in width is possible if volume is to be altered) must be kept on lockable wheels based SS structure of sufficient mechanical strength.

B. PROGRAMMABLE LOGIC CONTROLLER (PLC) FUNCTIONS

(1) All internal, external and input signals to the PLC should be optically isolated to more than 8kV. Output signals of the PLC may be optically isolated as and when found necessary for proper operation of the system.

(2) Switching On/Off sequence of the individual power supplies to the load is to be programmed using PLC. The voltages should always be applied in the following sequence only, (a) All air & water-cooling circuits for the load must be applied first. (b) Wait for 2 minutes before biasing the supplies. (c) The steps of LVPS voltage should be applied progressively over settable 2 to 3 minutes with 60 seconds pause after attaining full voltage. (d) Apply required operating voltage of HVPS.

(3) Switching-Off sequence of individual power supplies should also be programmed using PLC. HVPS voltage must always be removed first and faster within 10msec in case of any fault/failure within Integrated Power Supply, cooling system or the Load.

(4) All cooling circuits of the load must be removed after 5min of the power supplies shut down.

(5) With or without PLC (in case of fault), a TTL low signal must be provided to switch off the external experiment at load, within few microseconds before any of the individual supply is tripped or lowered below threshold level. TTL high should be provided while normal operation.

(6) The PLC of a reputed brand (Siemens, ABB etc.) may in general be included with (a) CPU of response time of ≤ 1 msec (b) Digital Input Module of input delay ≤ 1 msec (c) Digital Output Module (d) Analog Input Modules of more than 12bit resolution & 200Hz per channel sampling rate (e) Analog Output Modules of more than 12bit resolution & 50Hz per channel sampling rate.

Following are required for both of the individual power supplies:

(1) Control voltages, monitor voltages, limit set voltages and analog dials of 0 to 10 Volts corresponds to 0 to 1.2 times V_{max} or 0 to 1.2 times I_{max} .

(2) LVPS current where inrush in general is 1.5 times I_{max} , control voltages, monitor voltages, limit set voltages and analog dials, upper limit corresponding to 1.5 times I_{max} should be used.

C. MECHANICAL AND TERMINATIONS

1.	Terminations		Brass or SS Bolts only.
	(i)	HVDC and Return	Suitable Epoxy Bushing. (Else Feed through capacitors that will be supplied by IPR).
	(ii)	Power Ground	Isolated, connector with suitable Epoxy Bushing
	(iii)	Safety Ground	Panel should have provision to connect safety ground at two different locations.
	(iv)	Control signals	All input/output digital/analog signals should be suitably routed to terminal blocks as four distinct sets AI, AO, DI, DO.
2.	Enclosure		The LVPS may be installed within HVPS panel with perforated sheet separation. The separating SS sheets of 1mm thick may have ~50% of its area covered by punched holes of ~4mm diameter for air ventilation
3.	Housing		Generally conforming to standard IS: 12063-1987 and grade IP-41. Pest proof, SS housing with removable skins and/or doors, Necessary cooling fans, Dust filters at all air entries, Panel lighting, Suitable power and control cable entries, Capacitor discharge device like Idiot Stick etc.
4.	Ambient Temperature		45 °C Maximum
5.	Cooling		Forced Air

D. SPECIFICATIONS FOR THE INDIVIDUAL POWER SUPPLIES

1. HVDC POWER SUPPLY (HVPS)			
1.	Power Input	415V (Taps at $\pm 10\%$); 3 ϕ ; 50Hz	
2.	AC Mains Filter	Suitable EMI/EMC modular filter	
3.	Output cables	Co-axial type each for HV and Return.	
4.		1.1kV insulated Single core cable for Power Ground	
5.	Output Voltage Operating	0 to 10kV DC continuously variable	
6.	Output Voltage Test	12KV at 7A Maximum	
7.	HV Setting Precision	100V	
8.	Output Current (Continuous)	7A (Excluding bleeder current)	
9.	Short Duration Output Current	70A for 10ms at 0 to 10kV DC (1% Duty Cycle)	
10.	HVDC Return Path	Insulation level for floating at ≥ 8 kV DC	
11.	Ripple (Peak to Peak)	$\leq \pm 0.2\%$ at 10kV DC and $\leq \pm 1\%$ at 5kV DC	
12.	Load Regulation	$\leq \pm 1\%$ (for 0 to 100% load current change)	
13.	Line Regulation	$\leq \pm 0.5\%$ (for $\pm 10\%$ line voltage variation)	
14.	Dynamic Response		When sudden load is applied in typically 1ms.
	(i)	Over / Under shoot	$\pm 1\%$ Maximum
	(ii)	Settling time	≤ 3 ms to settle within $\pm 0.2\%$
	(iii)	Current rise time	~1 ms into resistive load

15.	Stability		
	(i)	Output Drift	$\leq 0.2\%$ per Hour.
	(ii)	Temperature sensitivity	$\leq 0.01\%$ per $^{\circ}\text{C}$
16.	Metering		All Analog Meters
	(i)	Input (Selector Switch)	Voltage (415V; 3 ϕ) and Current (R, Y, B)
	(ii)	Output	HVDC Voltage
			HVDC Current
		Floating Voltage (Between HV return and Power Ground)	
17.	Indications		LED Based Lamps
	(i)	Input	Voltage R, Y, B
	(ii)	Status	Auto/Manual, Supply On/Off, Ready (output voltage >2kV), External Trip, Emergency Off, LVPS Delay ON, Doors Open, Over Voltage, Over Current, Fault Output, Load Cooling, Supply Cooling etc.
18.	Feedback		Closed loop feedback control system to maintain the set output DC voltage within specified limit. Necessary protections to be provided for failure of feedback signal.
19.	Controls		Manual Selector Switch
	(i)	Auto	By using 0-10V external analog input (AI) signal
	(ii)	Manual	(a) Voltage Set By a front panel 10 turn readable potentiometer
20.	Manual Limits Setting (10 turn indoor potentiometer)		(a) Over Voltage Limit (12kV) (b) Over Current Limit (8.5A) (c) Floating Voltage Limit (100V)
21.	Analog Input (AI) signals (0 to 10V)		(a) Voltage Set (Auto Mode) for corresponding 0 to 12kV HVDC at 100V settable precision
22.	Analog Output (AO) Signal (0 to 10V)		(a) DC Output Voltage (b) DC Output Current (c) Bleeder current (d) Floating Voltage (e) LVPS Voltage (f) LVPS Current
23.	Digital Input (DI) Signals (TTL / Potential Free Contact PFC)		(a) Fast Trip -TTL (Crowbar in μs) (b) Slow Trip -PFC (without crowbar in ms) (c) Start / Stop -PFC (Normal Start or Stop)
24.	Digital Output (DO) Signals (Should not Multiplex the output signals)		(a) Supply Trip -TTL (b) Supply ON -TTL (c) Supply OFF -TTL (d) Ready to Operate -TTL (e) Over Voltage Fault -TTL (f) Over Current Fault -TTL (g) Supply Fault -PFC (h) Crowbar Fired -TTL (i) Interlock Open -TTL

25.	Protections		All active high or as suitable for fool proof operation
	(i)	Series Resistance	(2X10) 20Ω Non Inductive Non Capacitive
	(ii)	Shunt Resistance	Suitable Bleeder $\geq 500W$ for Stable Operation
	(iii)	Arc Protection	Light activated, within HVDC chamber
	(iv)	DC Over Voltage	Settable from 3 to 12kV
	(v)	DC Over Current	(a) Settable from 20 to 120% of rating measured on HT, (b) Series over current relay set at 120% of rating.
	(vi)	High di/dt (Load Arc)	Rate of current rise sensed by a pulse CT
	(vii)	Crowbar Trigger for Fault Energy ≤ 50 Joules for Wire burn test	Within 10μs including detection by Over Voltage, Over Current, High di/dt, External Trip, Additional Inputs etc.
(viii)	Others	Interlocks according to switching on/off sequence, Doors open, HV On, Danger markings etc.	
26.	Interlock		
	(i)	Self	Power Supply Open/Close for OFF/ON -PFC Power Supply Cooling OK -PFC Load Water Cooling OK -PFC Bleeder Over Current -PFC Floating Over Voltage -PFC Air Cooling OK -PFC
(ii)	Other Supplies	Trip HVPS if (1) HVPS faults (2) LVPS faults (3) External faults.	
27.	Possible Topology (Any other more suitable may be quoted)		Single or Multiple Modules including Bridge rectifier, Filter, Controlled PWM at primary of HF transformer, HF rectifier, filter, crowbar, feedback and monitoring etc. PWM at DC output is not preferred.

2. LVAC POWER SUPPLY (LVPS)		
1.	Power Input	230V (Taps at $\pm 10\%$); 1 ϕ ; 50Hz
2.	AC Mains Filter	Suitable EMI/EMC modular filter
3.	Output cable	Suitable flexible cables for both Supply and Return.
4.	Output Voltage (Operating)	12V AC Continuous with Center Tapping
5.	Output Current	0 to 120A Continuous
6.	Max. Surge Current	Limited to $\leq 200A$ by using High Impedance Transformer
7.	FLPS and HVPS Return Path	Insulation level for floating at $\geq 8kV$ DC
8.	Load Regulation	$\leq \pm 5\%$ (for 100% load change) Preferably
9.	Voltage Rise Time	Steps of 30%, 60%, and 100% for soft start. Sequential switching of suitable resistances may be undertaken at transformer primary by means of timers and contactors.
10.	Metering at Output	V & I Analog Meters on primary calibrated to secondary
11.	Indications	
	(i)	Status

12.	Controls		Manual Selector Switch
	(i)	Auto	By using 5V external signal for LVPS On/Off
	(ii)	Manual	By a front panel contact switch
13.	Manual Limits Setting (10 turn indoor accessible potentiometer)		(a) Over Voltage Limit (b) Over Current Limit
14.	Analog Output (AO) Signal (0 to 10V)		(a) AC Output Voltage (b) AC Output Current
15.	Digital Input (DI) Signals (TTL / Potential Free Contact PFC)		(a) Start / Stop -PFC (Normal Start or Stop)
16.	Digital Output (DO) Signals (TTL / Potential Free Contact PFC)		(a) Supply Delay ON -TTL (b) Supply ON -TTL (c) Supply OFF -TTL (d) Supply Ready -TTL (e) Over Voltage Fault -TTL (f) Over Current Fault -TTL (g) Supply Fault -PFC (h) Cooling Interlock Open -TTL
17.	Protections		All active high /as suitable for fool proof operation
	(i)	AC Over Voltage	Settable from 10 to 15V
	(ii)	AC Over Current	(a) Settable from 20 to 120% of rating.
	(iii)	Others	Interlocks to coordinate switch on/off sequence, Doors open, Danger markings etc.
18.	Interlock		Open/Close for Power Supply OFF/ON -PFC Air Blower Fault -PFC Water Cooling Fault -PFC Bleeder over Current -PFC External Interlock -PFC (Open–LVPS OFF; Close- LVPS ON)
19.	Possible Topology (Any other more suitable may be quoted)		Sequential switching of suitable resistances may be undertaken by means of timers/PLC and relays/contactors at primary of the transformer with center tapped secondary. (Without modifying sine wave shape of the mains)

E. ACCEPTANCE TESTS PROCEDURE

This will include tests to ensure that the Integrated Power Supply meets all the above-mentioned specifications. The tests will be carried out at the factory before dispatch and at Institute for Plasma Research during commissioning. The tests mentioned below are to be performed as minimum required and will be elaborated within three months of placing the order with mutual discussions and understanding.

(i) COMPONENT LEVEL: Brand names of most of the major components to be used must be submitted with the quotation. Sufficient margins must be kept to ensure smooth operation and longer life of the Integrated Power Supply. Only reputed brands and make should be used. Specifications and Tests Reports of every individual component that is used in fabrication of the Power Supply must be submitted. Submit the technical data sheet of the components where such tests are not possible to be conducted.

(ii) SUBSYSTEM LEVEL: Stage wise progress will be monitored. IPR representative should be invited for witnessing the relevant tests at pre-decided time intervals in order to ensure quality and optimized progress. The stage wise progress that should be executed in order to complete the specified Integrated Power Supply in the given time duration will be elaborated within one month of placing the order with mutual discussions and understanding.

(iii) INDIVIDUAL POWER SUPPLIES: Both of the specified HVPS, LVPS must be tested for the following,

Sl.No	Specification	Tests to be Performed
1.	No-load test	Rise time, Fall time, Voltage setting resolution, Minimum DC output Voltage, Maximum DC output Voltage etc.
2.	Load Test	Rise time, Fall time, Voltage setting resolution, Minimum DC output Voltage, Maximum DC output Voltage, Load Regulation, Line regulation, Dynamic Response, Ripple, Stability etc.
3.	Monitoring	Resolution, Accuracy, Calibration etc.
4.	Control	Auto, Manual Mode of Operation.
5.	Settings	Settable Parameters like Over Voltage, Over Current etc.
6.	Floating	HVPS return floated to 8kV with respect to ground (With observation of effect on monitoring signals).
7.	Indications	Proper operation of monitors, indicators and signals like AI, AO, DI, DO etc.
8.	Protections	Proper operation of all protections and Interlocks.
9.	Shielding	Effectiveness in terms of EMI/EMC within and outside the Individual and Integrated Power Supply.
10.	Wire-burn test	With 30AWG (Diameter 0.225mm), 6" long soft copper wire for anticipated fault energy ≤ 50 Joules as per attached details.
11.	Others	Remaining of the specifications.

(iv) OVERALL INTEGRATED POWER SUPPLY: At least following must be tested,

(1) Systematic switching On/Off of the individual power supplies as per given sequence, specified and settable delays. Performance of various inter-supplies' interlocks.

(2) Continuous full load operation of the power supply system for more than 8Hours without performance degradation.

(3) Temperature within the Power Supply should not be raised 10 degrees above ambient while in equilibrium during continuous operation.

(4) Performance of each of the above mentioned parameters of the power supplies while operating simultaneously with the remaining power supplies in a particular configuration.

(5) Remote operation of the integrated power supply.

F. WIRE BURN TEST PROCEDURE

The fault sensing element for Over Voltage, Over Current, test push button for crowbar, external and other protections etc must sense a fault condition. The fault signals i.e. signal above threshold will trigger the crowbar. The crowbar is a fault energy-diverting element such as thyatron, ignitron, SCR etc. Typical fault energy diverting element fires within few microseconds of the fault detection and remove HVDC from the load in few microseconds.

Only HVPS need this testing. The power supply should be short circuited through 6 inch long soft copper wire of diameter 0.255mm i.e. 30AWG. The wire should remain intact to ensure that total energy dumped in the wire is less than 50 Joules. These 50 Joules of fault energy includes

energy from the storage devices and the follow on current from the power supply before tripping.

The resistance R1 (Figure 2) is used to limit the peak current into the fault energy diverting element and load on the transformer & rectifier. R2 should be large enough to keep sufficient voltage across fault energy diverting element required for proper firing. R1 and R2 should be such as to damp the circuit ringing sufficiently for preventing current reversal into the fault energy-diverting element. This may cause the fault energy-diverting element to open before the fault conditions are cleared. Crowbar test switch is a high voltage air or vacuum construction.

2. DATA-SHEETS

A. GENERAL SPECIFICATION

S.NO	DESCRIPTION	VALUE REQUIRED	VALUE OFFERED
1.	Scope of bidder	As specified	
2.	Mains input voltage	415V±10%; 3φ; 50Hz; N, PE;	
3.	Input Power	120kVA	
4.	Overall Efficiency		
5.	System suitability	Indoor	
6.	All power transformers	Dry type only	
7.	All rectifiers	Dry type only	
8.	Use of oil	Not recommended anywhere	
9.	Performance terminals	Load end of the output cables	
10.	Supply to load distance	10m	
11.	Grounding scheme	As specified	
12.	Spare utility sockets	230V, 5 & 15A (2 Nos. each)	
13.	Fault energy of HVPS	≤ 50Joules	
14.	Total Preferred Space	W 2000 X D 1200 X H 2400mm (Increase in width is possible)	
15.	Rectifier Arrays	(i) Suitable compensation techniques must be used.	
		(ii) Least possible number of elements in series, with sufficient current rating to accommodate crowbar current.	
16.	Submit details of Topology Used	(i) HVDC Power Supply	
		(ii) LVAC Power Supply	
17.	Wheels	lockable wheels based SS structure of sufficient mechanical strength.	
		Easy movement with all components assembled, would be checked.	

B. PLC FUNCTIONS

S.NO	DESCRIPTION/ SPECIFICATION	VALUE OFFERED
1.	All internal, external and input signals to PLC should be optically isolated for ≥8KV.	
2.	Switching On/Off sequence of individual power supplies to be programmed using PLC.	
3.	The voltages would always be applied in the mentioned sequence only.	
4.	Switching Off sequence of individual power supplies would also be programmed using PLC.	
5.	The voltages should be switched off in the reverse order of startup.	

6.	All of the load cooling circuits must be removed only after 5min of the biasing supplies are shut down.	
7.	With or without PLC, TTL low signal must be provided to switch off the external experiment at load, within few microseconds in case of a fault before any of the supply is tripped or lowered below threshold level. TTL high should be provided otherwise.	
8.	Tripping of one supply need to act on other supply. It should also generate signal for load & external experiment with or without help of PLC.	
9.	Reputed brand of the PLC (Siemens, ABB etc).	
10.	(a) CPU of response time of ≤ 1 msec	
	(b) Digital Input Module of input delay ≤ 1 msec	
	(c) Digital Output Module	
	(d) Analog Input Modules of more than 12bit resolution & 200Hz per channel sampling rate	
	(e) Analog Output Modules of more than 12bit resolution & 50Hz per channel sampling rate.	

C. MECHANICAL AND TERMINATIONS

S.NO	DESCRIPTION	VALUE REQUIRED	VALUE OFFERED
1.	Terminations	Brass or SS Bolts only.	
	(i) HVDC and Return	Suitable Epoxy Bushing. (Else Feed through capacitors that will be supplied by IPR).	
	(ii) Power Ground	Isolated, connector with suitable Epoxy Bushing	
	(iii) Safety Ground	Panel should have provision to connect safety ground at two different locations.	
	(iv) Control signals	All input/output digital/analog signals should be suitably routed to terminal blocks as four distinct sets AI, AO, DI, DO.	
2.	Enclosure	The LVPS may be installed within HVPS panel with perforated sheet separation. The separating SS sheets of 1mm thick may have ~50% of its area covered by punched holes of ~4mm diameter for air ventilation	

3.	Housing	Generally conforming to standard IS:12063-1987 and grade IP-41. Pest proof, SS housing with removable skins and/or doors, Necessary cooling fans, Dust filters at all air entries, Panel lighting, Suitable power and control cable entries, Capacitor discharge device like Idiot Stick etc.,	
4.	Ambient Temp.	45 °C Maximum	
5.	Cooling	Forced Air	

D. INDIVIDUAL POWER SUPPLIES

1. HVDC POWER SUPPLY (HVPS)			
S.NO	DESCRIPTION	VALUE REQUIRED	VALUE OFFERED
1.	Power Input	415V (Taps at $\pm 10\%$); 3 ϕ ; 50Hz	
2.	AC Mains Filter	Suitable EMI/EMC modular filter	
3.	Output cable	Co-axial type: HV and Return.	
4.	Output Voltage	0 to 10kV DC continuous	
5.	Output Voltage Test	12KV at 7A Maximum	
6.	HV Setting Precision	100V	
7.	Output Current	7A (Exclude bleeder current at any output voltage)	
8.	Short Duration Output Current	70A for 10ms at 0 to 12kV DC (1% Duty Cycle)	
9.	HVDC Return Path	Insulation level ≥ 8 kV DC	
10.	Ripple (Peak to Peak)	$\leq \pm 0.2\%$ at 10kV DC and $\leq \pm 1\%$ at 5kV DC	
11.	Load Regulation	$\leq \pm 1\%$ (for 100% load change)	
12.	Line Regulation	$\leq \pm 0.5\%$ ($\pm 10\%$ line variation)	
13.	Dynamic Response	When sudden load is applied in typically 1ms.	
	(i)	Over /Under shoot	$\pm 1\%$ Maximum
	(ii)	Settling time	≤ 3 ms to settle within $\pm 0.2\%$
	(iii)	Current rise time	~ 1 ms into resistive load
14.	Stability		
	(i)	Output Drift	$\leq 0.2\%$ per Hour.
	(ii)	Temp. Sensitivity	$\leq 0.01\%$ per °C
15.	Metering	Analog Meters	
	(i)	Input (Selector Switch)	Voltage (415V; 3 ϕ) and Current (R, Y, B)
	(ii)	HVDC Voltage	
		Accuracy	
	(iii)	HVDC Current	
		Accuracy	
(iv)	Floating Voltage		
	Accuracy		

16.	Indications		LED Based Lamps	
	(i)	Input	Voltage R,Y, B	
	(ii)	Status	Auto/Manual, Supply On/Off, Ready, External Trip, Emergency Off, LVPS Delay ON (External), Doors Open, Over Voltage, Over Current, Fault Output, Load Cooling, Power Supply Cooling etc.	
17.	Feedback		Closed loop feedback control system to maintain the set output DC voltage within specified limit.	
			Necessary protections to be provided for failure of feedback signal.	
18.	Controls		Manual Selector Switch	
19.	(i)	Auto	By using 0-10V external signal for corresponding 0 to 12kV HVDC at 100V settable precision	
20.	(ii)	Manual	By a front panel 10 turn readable potentiometer	
21.	Manual Limits Setting (10 Turn potentiometer)		(a) Over Voltage Limit (12kV) (b) Over Current Limit (8.5A) (c) Floating Voltage Limit (100V)	
22.	Analog Input (AI) signals (0 to 10V)		(a) Voltage Set (Auto Mode)	
23.	Analog Output (AO) Signal (0 to 10V)		(a) DC Output Voltage (b) DC Output Current (c) Bleeder Current (d) Floating Voltage	
	Band Width			
	Sampling Rate			
24.	Digital Input (DI) Signals (TTL / Potential Free Contact PFC)		(a) Fast Trip -TTL (b) Slow Trip -PFC (c) Start / Stop -PFC	
25.	Digital Output (DO) Signals (TTL / Potential Free Contact PFC)		(a) Supply Trip -TTL (b) Supply ON -TTL (c) Supply OFF -TTL (d) Supply Ready -TTL (e) Over Voltage Fault -TTL (f) Over Current Fault -TTL (g) Supply Fault -PFC (h) Crowbar Fired -TTL (i) Interlock Open -TTL	

26.	Protections	All active high or as required for fool proof operation	
	(i) Series Resistance	2 X 10Ω Non Inductive Non Capacitive	
	(ii) Shunt Resistance	Suitable Bleeder ≥500W for Stable Operation	
	(iii) Light Activated Arc Protection	To be provided with HVDC chamber	
	(iv) DC Over Voltage	Settable from 3 to 12kV	
	(v) DC Over Current	(a) Settable from 20 to 120% of rating measured on HT.	
		(b) Series over current relay set at 120% of rating.	
	(vi) High di/dt (Load Arc)	Rate of current rise sensed by a pulse CT	
	(vii) Crowbar Trigger for Fault Energy ≤50J (Wire burn test)	Within 10μs including detection by Over Voltage, Over Current, High di/dt, External Trip, Additional Inputs etc.	
(viii) Others	Interlocks according to switching on/off sequence, Doors open, HV On, Danger markings etc.		
27.	Interlock		
	(i) Self	Power Supply Open/Close for OFF/ON -PFC Power Supply Cooling -PFC Load Water Cooling -PFC Bleeder over Current -PFC Floating OV -PFC Air Cooling -PFC	
	(ii) Other Supplies	Trip HVPS if (1) HVPS faults (2) LVPS faults (3) External faults.	
28.	Possible Topology (Any other more suitable may be quoted)	Single or Multiple Modules including Bridge rectifier, Filter, Controlled PWM at primary of HF transformer, HF rectifier, filter, crowbar, feedback and monitoring etc. PWM at DC output is not preferred.	

2. LVAC POWER SUPPLY (LVPS)

S.NO	DESCRIPTION	VALUE REQUIRED	VALUE OFFERED
1.	Power Input	240V (Taps at ± 10%); 1φ; 50Hz	
2.	AC Mains Filter	Suitable EMI/EMC modular filter	
3.	Output cable	Suitable flexible cables for both Supply and Return.	
4.	Output Voltage	12V AC with Center Tapping	
5.	Output Current	0 to 120A Continuous	

6.	Max. Surge Current	Limited to $\leq 200A$ by using high impedance transformer	
7.	FLPS & HVPS Return Path	Insulation level for floating at $\geq 8kV$ DC	
8.	Load Regulation	$\leq \pm 5\%$ (for 100% load change) preferably	
9.	Voltage Rise Time	Steps of 30%, 60%, and 100% for soft start. Sequential switching of suitable resistances may be undertaken at transformer primary by means of timers and contactors.	
10.	Metering at Output	V & I Analog Meters on primary calibrated to secondary	
11.	Indications	LED Based Lamps	
	(i) Input	Voltage R, Y, B	
	(ii) Status	Auto/Manual, LVPS Delay ON, LVPS On/Off, Ready to Start, Trip Status, Over Voltage, Over Current, Fault Output etc.	
12.	Controls	Manual Selector Switch	
13.	(i) Auto	By using 5V external signal for LVPS On/Off	
14.	(ii) Manual	By a front panel contact switch	
15.	Manual Limits Setting 10 turn potentiometer	(a) Over Voltage Limit (b) Over Current Limit	
16.	Analog Output (AO) Signal (0 to 10V)	(a) AC Output Voltage (b) AC Output Current	
	Band Width		
	Sampling Rate		
17.	Digital Input (DI) Signals (TTL / PFC)	(a) Start / Stop - PFC (Normal Start or Stop)	
18.	Digital Output (DO) Signals (TTL / Potential Free Contact PFC)	(a) Supply Delay ON -TTL (b) Supply ON -TTL (c) Supply OFF -TTL (d) Supply Ready -TTL (e) Over Voltage Fault -TTL (f) Over Current Fault -TTL (g) Supply Fault -PFC (h) Cooling Interlock Open -TTL	
19.	Protections	All active high or as required for fool proof operation	
	(i) AC Over Voltage	Settable from 10 to 15V	
	(ii) AC Over Current	(a) Settable from 20 to 120%.	
	(iii) Others	Interlocks to coordinate switch on/off sequence, Doors open, Danger markings etc.	
20.	Interlock	Power Supply OFF/ON -PFC Air Blower Fault -PFC Water Cooling Fault -PFC Bleeder over Current -PFC External Interlock -PFC	

21.	Possible Topology (Any other more suitable may be quoted)	Sequential switching of suitable resistances may be undertaken by means of timers/PLC and relays/contactors at primary of the transformer with center tapped secondary. (Without modifying sine wave shape of the mains)	
-----	---	--	--

E. ACCEPTANCE TESTS PROCEDURE

S.NO	DESCRIPTION	VALUE REQUIRED	VALUE OFFERED
1.	General	<p>The tests required to ensure that the integrated power supply meets all mentioned specifications</p> <p>All the specified tests will be carried out at the factory or any reputed laboratory before dispatch</p> <p>The tests will also be carried out at the Institute for Plasma Research during commissioning.</p> <p>The tests specified will be elaborated within three months of placing the order with mutual discussions and understanding.</p>	
2.	<p>Tests to be performed</p> <p>(i) Component level</p> <p>(ii) Subsystem level</p>	<p>Brand names of most of the major components to be used would be submitted with the quotation.</p> <p>Sufficient margins would be kept to ensure smooth operation and longer life of the Integrated Power Supply.</p> <p>Only reputed brands and make should be used.</p> <p>Specifications and Tests Reports of every individual component that is used in fabrication of the Power Supply should be submitted.</p> <p>Submit the technical data sheet of the components where such tests are not possible to be conducted.</p> <p>Stage wise progress would be monitored by IPR representatives as mentioned in specification, in order to ensure quality and optimized progress.</p> <p>The stage wise progress that should be executed in order to complete the ordered requirements in the given time duration will be elaborated within one month of placing the order with mutual discussions and understanding</p>	

3.	(iii) Individual Power Supplies	HVPS would be tested as specified.	
		LVPS would be tested as specified.	
	(iv) Overall Integrated Power Supply	(1) Systematic switching On /Off of each of the Power Supplies as per given sequence and specified / settable delays. Performance of various inter-supply interlocks.	
		(2) Full load operation of the integrated power supply for more than 8Hours without performance degradation.	
		(3) Temperature within the Power Supply should not be raised 10 ⁰ C above ambient while in equilibrium during continuous operation.	
		(4) Performance of each of the above mentioned parameters of the power supplies while operating simultaneously with the remaining power supplies in a particular configuration.	
	(5) Remote operation of the integrated power supply.		
4.	Other tests proposed by bidder (if any)	HVDC Power Supply	
		LVAC Power Supply	
5.	Tests that cannot be performed on HV Power Supply		
6.	Tests that cannot be performed on LV Power Supply		

F. WIRE BURN TEST PROCEDURE

S.NO	DESCRIPTION	VALUE REQUIRED	VALUE OFFERED
1.	General	The fault-sensing element for Over Voltage, Over Current, test push button for crowbar, external and other protections must sense a fault condition. The fault signal will trigger the crowbar.	
		Proposed fault sensing element for HVPS	
		Proposed fault sensing element for LVPS	
		Fault energy diverting element fires within few μ s of the fault detection and remove all voltages and currents from the load in few μ s.	
		Proposed fault energy diverting element for HVPS	
		Proposed fault energy diverting element for LVPS	
2.	Test Procedure	As mentioned with the specifications	
3.	Operation Details	Acceptable for HVDC Power Supply	
		Acceptable for LVAC Power Supply	

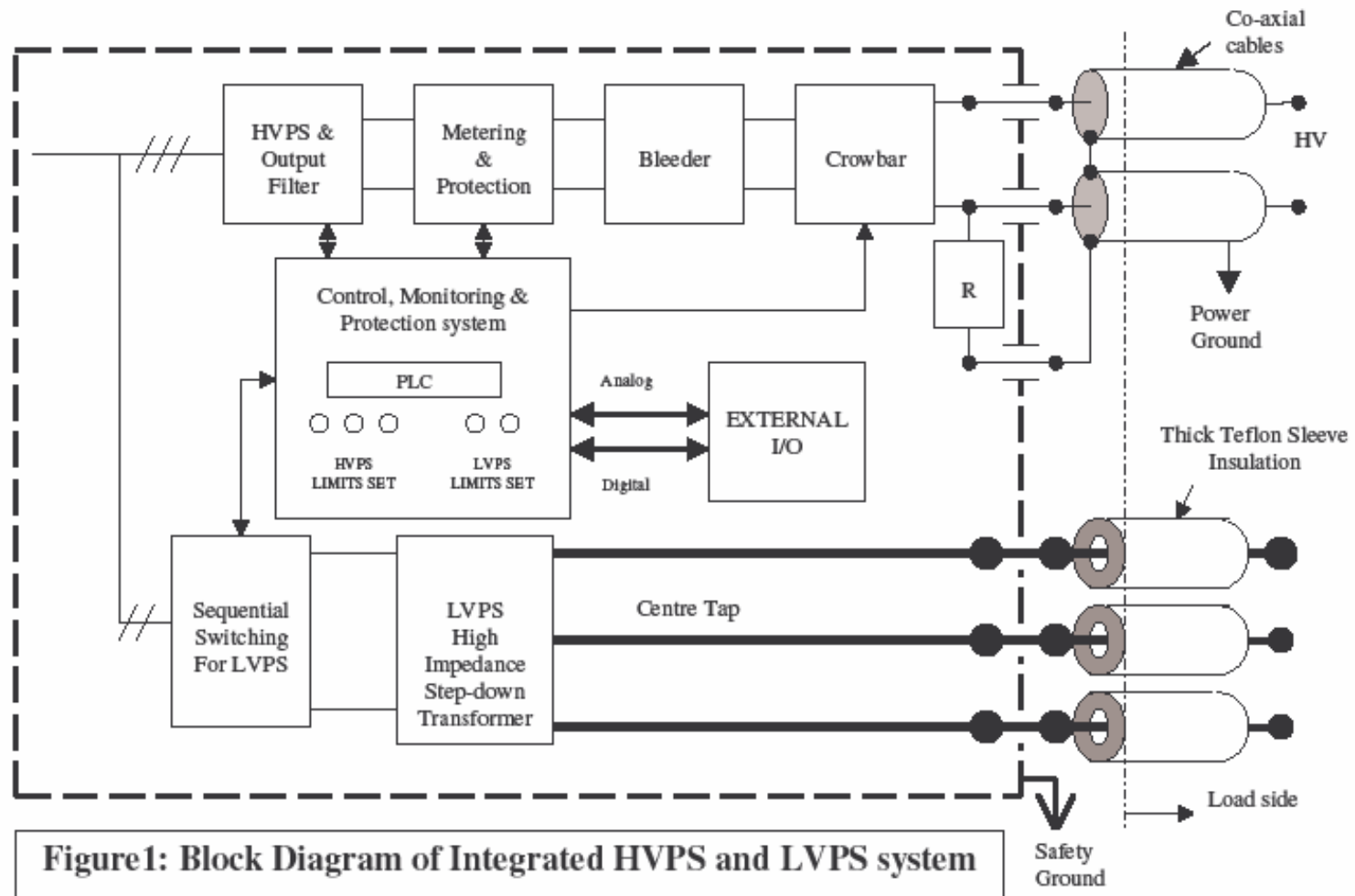

Figure1: Block Diagram of Integrated HVPS and LVPS system

