

H G F E D C B A

4

3

2

1

4

3

2

1

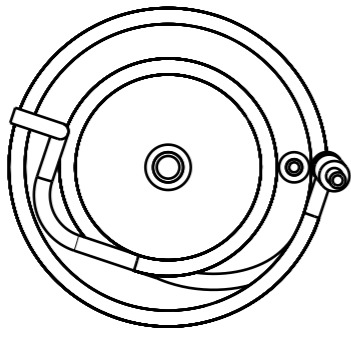

K

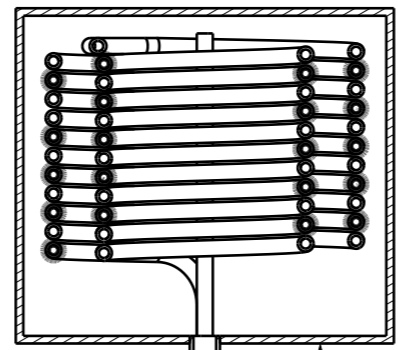
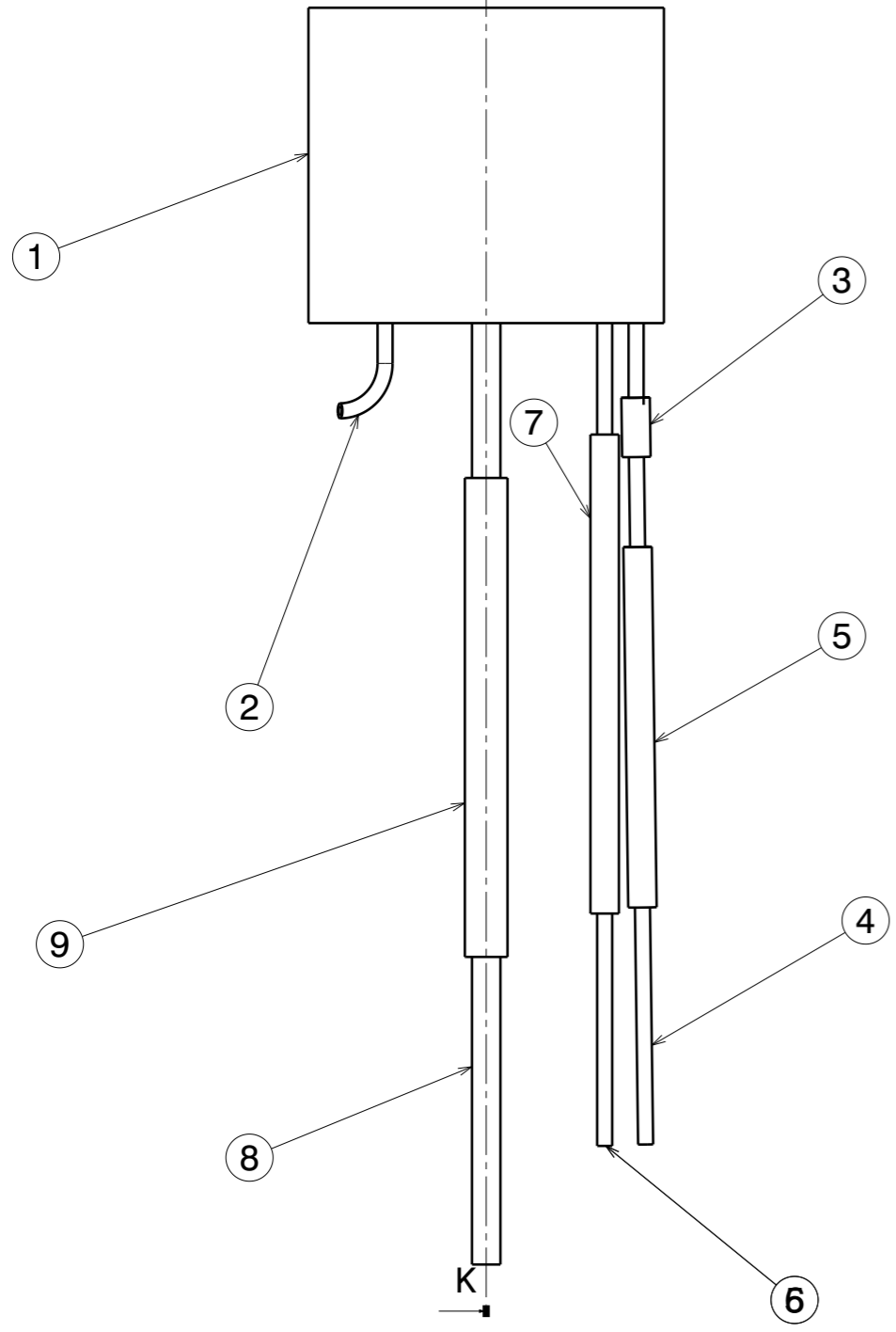

C

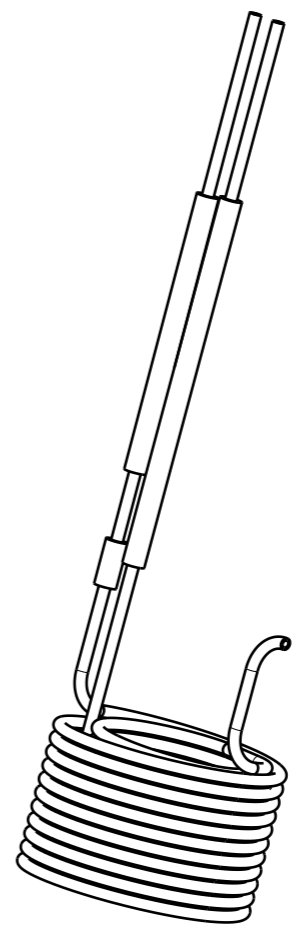

Component No	Component Name	Drawing No.	Material
1	Precooler Diwar	80KPRECOOLER-005	SS-304
2	H2 Precooler Coil First Stage	80KPRECOOLER-008	OFHC COPPER
3	CU-SS Pipe Joint	80KPRECOOLER-001	OFHC COPPER
4	H2 Inlet Pipe	80KPRECOOLER-009	SS-304
5	H2 Inlet Jacket	80KPRECOOLER-002	SS-304
6	LN2 Inlet Pipe	80KPRECOOLER-006	SS-304
7	LN2 Inlet Jacket	80KPRECOOLER-003	SS-304
8	LN2 Outlet Pipe	80KPRECOOLER-007	SS-304
9	N2 Outlet Jacket	80KPRECOOLER-004	SS-304

This drawing is our property. It can't be reproduced or communicated without our written agreement.

**INSITITUTE FOR PLASMA RESEARCH BHAT, GANDHINAGAR**

DRAWING TITLE

DRAWN BY  
**KRISHANPAL**

DATE  
10/10/2016

**H2 FIRST STAGE PRECOOLER ASSEMBLY**

CHECKED BY  
**SAMIRAN**

DATE  
10/10/2016

SIZE  
**A3**

DRAWING NUMBER  
**80KPRECOOLER-010**

REV  
**0**

DESIGNED BY  
**DEVESH**

DATE  
XXX

SCALE 1:1 WEIGHT(kg) 0.02 SHEET 10/10

Section view K-K

Note: All dimensions are in mm  
Remove all sharp edges

H G F E D C B A

D C B A

4

3

2

1

4

3

2

1

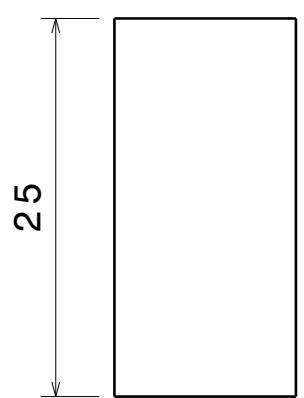
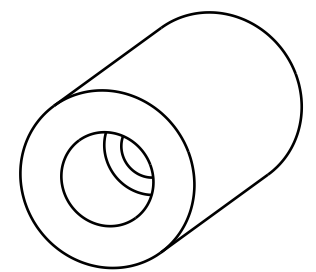

A

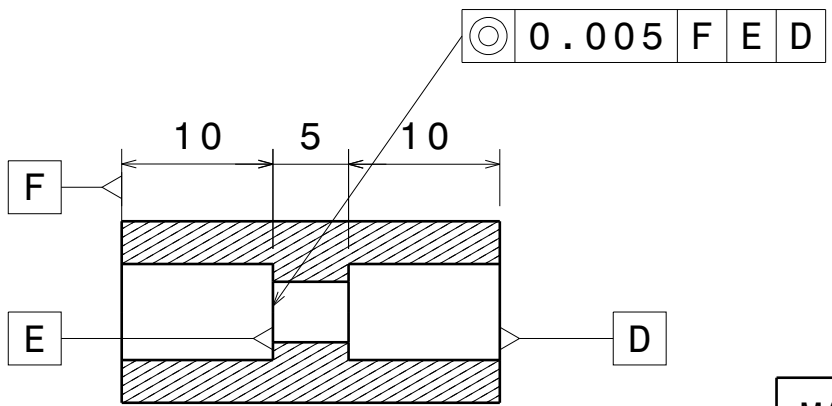
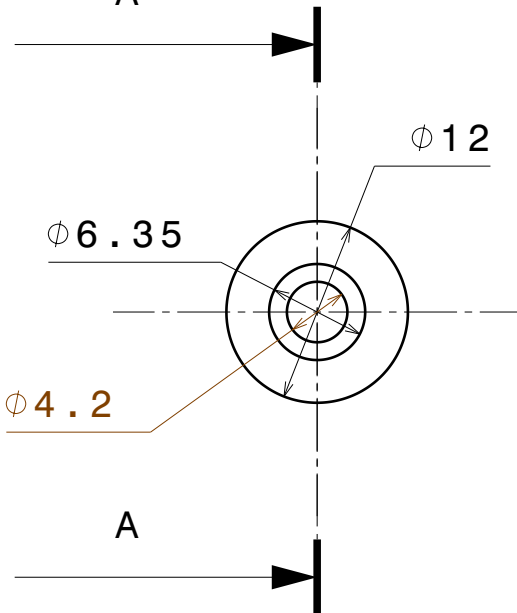

Section view A-A

MATERIAL	OFHC COPPER
QUANTITY	1

This drawing is our property.  
It can't be reproduced  
or communicated without  
our written agreement.

**INSITITUTE FOR PLASMA  
RESEARCH BHAT, GANDHINAGAR**

DRAWN BY  
**KRISHANPAL**

DATE  
10/10/2016

DRAWING TITLE  
**CU SS Pipe Joint**

CHECKED BY  
**SAMIRAN**

DATE  
10/10/2016

SIZE  
**A4**

DRAWING NUMBER  
**80KPRECOOLER-001**

REV  
**0**

DESIGNED BY  
**DEVESH**

DATE  
xxx

SCALE  
**1:1**

WEIGHT(kg) **0.02**

SHEET **1/10**

Note: All dimensions are in mm  
Remove all sharp edges

D C B A

D

C

B

A

4

4

3

3

2

2

1

1

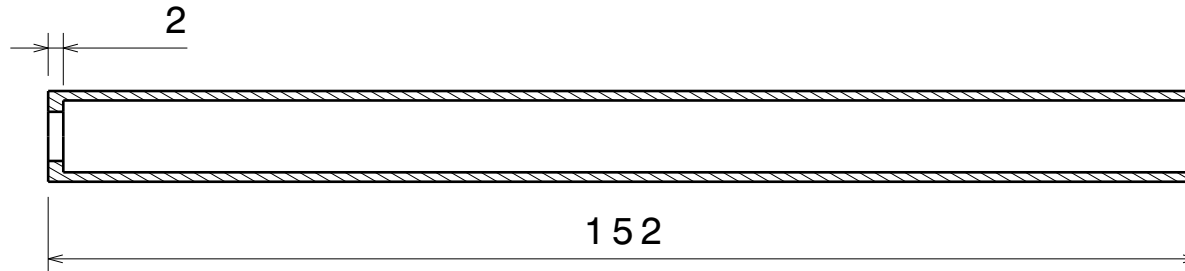
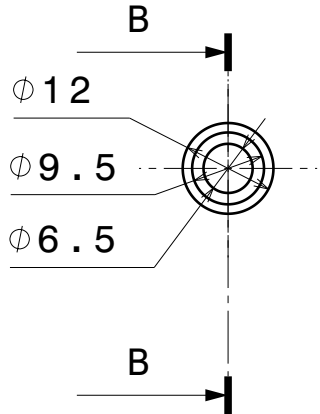
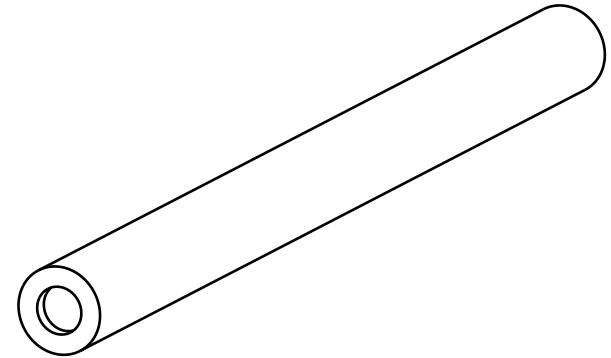

Section view B-B

MATERIAL	SS-304
QUANTITY	1

This drawing is our property. It can't be reproduced or communicated without our written agreement.		<b>INSITITUTE FOR PLASMA RESEARCH BHAT, GANDHINAGAR</b>				
DRAWN BY <b>KRISHANPAL</b>		DATE 10/10/2016		DRAWING TITLE <b>H2 INLET JACKET</b>		
CHECKED BY <b>SAMIRAN</b>		DATE 10/10/2016				
DESIGNED BY <b>DEVESH</b>		DATE xxx		SIZE <b>A4</b>	DRAWING NUMBER <b>80KPRECOOLER-002</b>	REV <b>0</b>
Note: All dimensions are in mm Remove all sharp edges		SCALE 1:1	WEIGHT (kg) 0.02	SHEET 2/10		

D

A

D

C

B

A

4

4

3

3

2

2

1

1

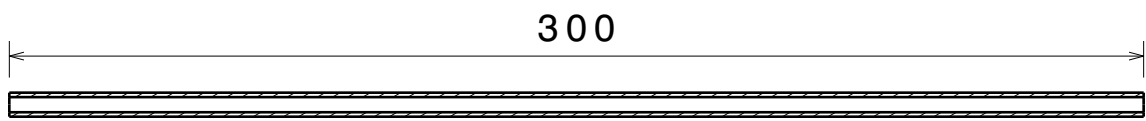
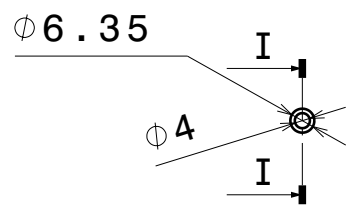

Section view I-I

MATERIAL	SS-304
QUANTITY	1

This drawing is our property.  
It can't be reproduced  
or communicated without  
our written agreement.

**INSITITUTE FOR PLASMA  
RESEARCH BHAT, GANDHINAGAR**

DRAWN BY <b>KRISHANPAL</b>	DATE 10/10/2016
-------------------------------	--------------------

DRAWING TITLE <b>H2 INLET PIPE</b>	
---------------------------------------	--

CHECKED BY <b>SAMIRAN</b>	DATE 10/10/2016
------------------------------	--------------------

SIZE <b>A4</b>	DRAWING NUMBER <b>80KPRECOOLER-009</b>	REV <b>0</b>
-------------------	---	-----------------

DESIGNED BY <b>DEVESH</b>	DATE xxx
------------------------------	-------------

SCALE 1:1	WEIGHT(kg) 0.02	SHEET 9/10
--------------	--------------------	---------------

Note:All dimenssions are in mm  
Remove all sharp edges

D

A

H G F E D C B A

4 3 2 1

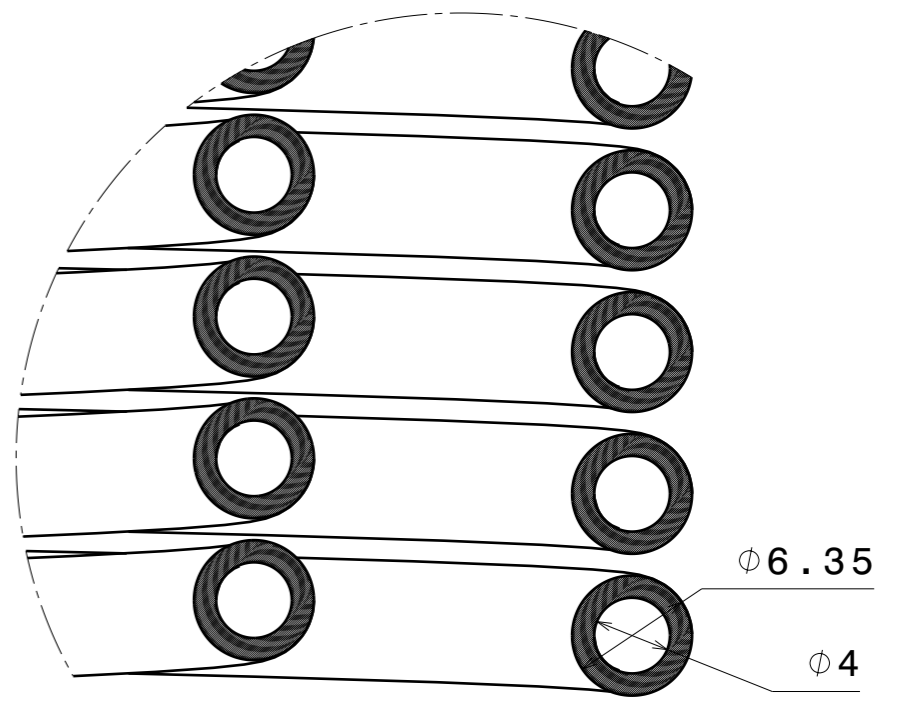
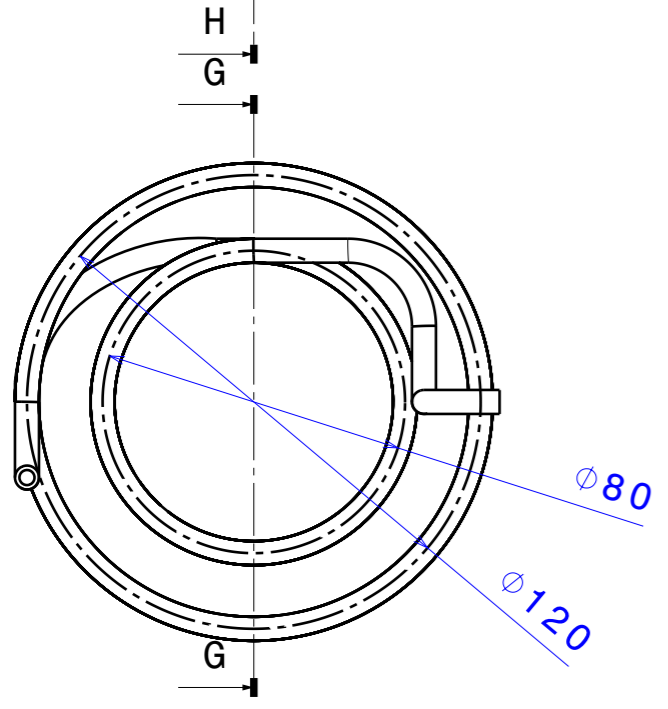
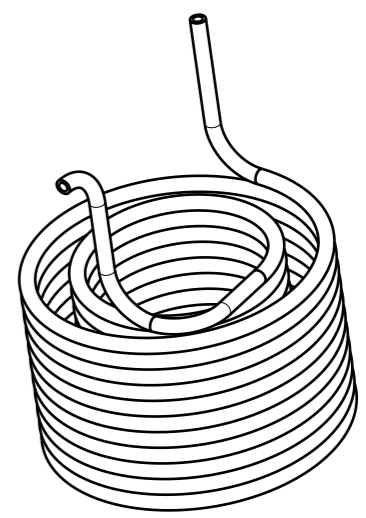
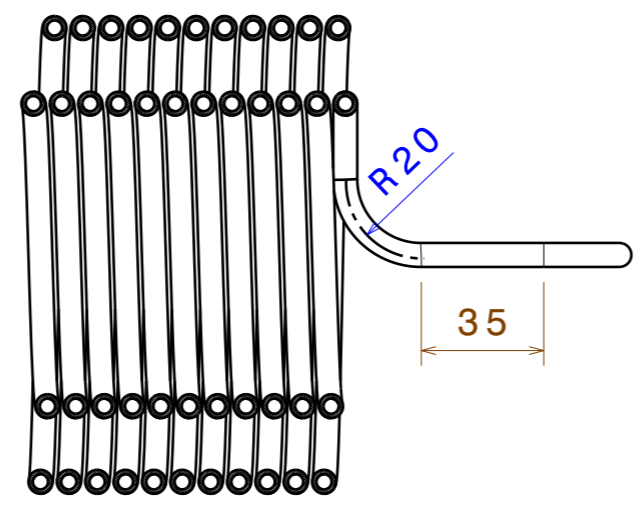
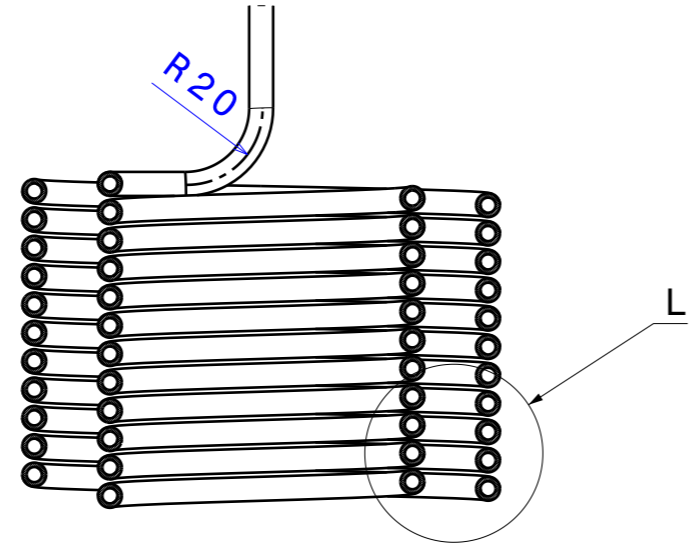
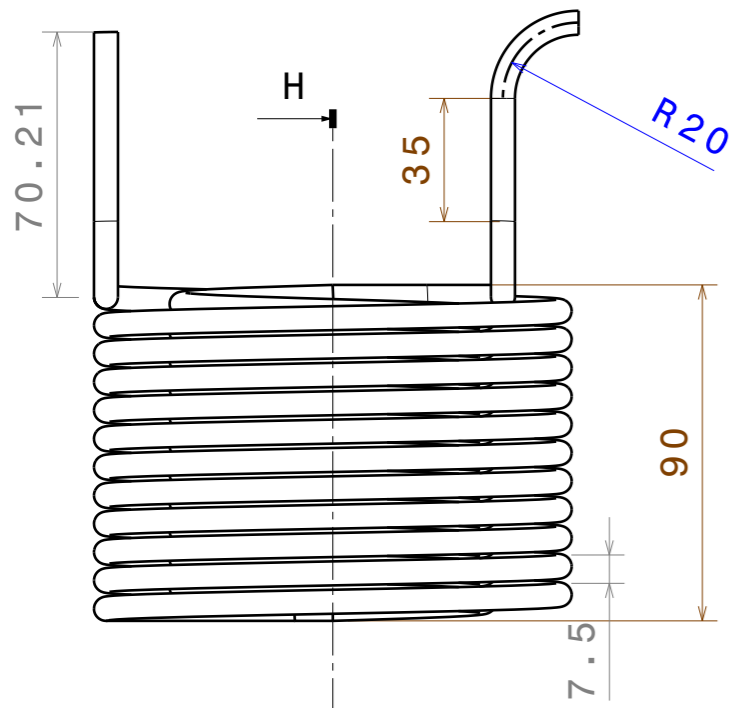

MATERIAL	OFHC COPPER
QUANTITY	1

This drawing is our property. It can't be reproduced or communicated without our written agreement.		<b>INSITITUTE FOR PLASMA RESEARCH BHAT, GANDHINAGAR</b> DRAWING TITLE H2 PRECOOLER COIL FISRT STAGE		
DRAWN BY <b>KRISHANPAL</b>	DATE 10/10/2016			
CHECKED BY <b>SAMIRAN</b>	DATE 10/10/2016	SCALE 1:1	WEIGHT (kg) 0.02	SHEET 8/10
DESIGNED BY <b>DEVESH</b>	DATE XXX			

Note: All dimensions are in mm  
Remove all sharp edges

H G B A

D

C

B

A

4

4

3

3

2

2

1

1

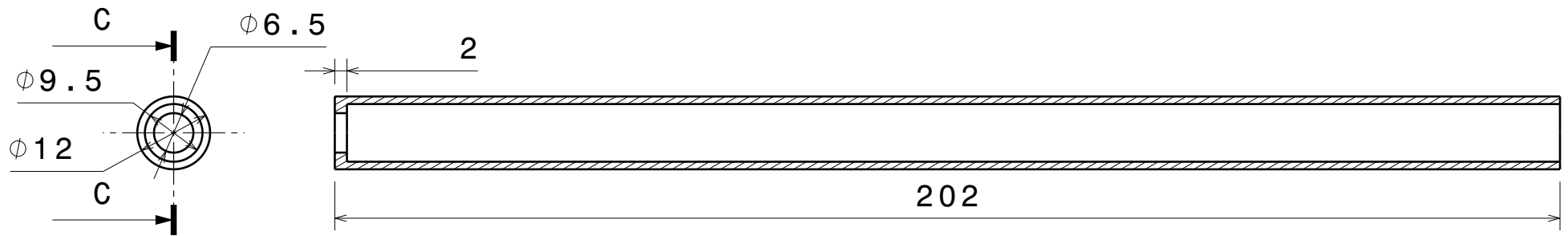
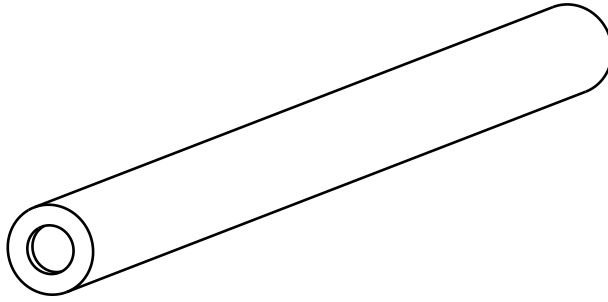

Section view C-C

MATERIAL	SS-304
QUANTITY	1

This drawing is our property. It can't be reproduced or communicated without our written agreement.		<b>INSITITUTE FOR PLASMA RESEARCH BHAT, GANDHINAGAR</b>			
		DRAWING TITLE <b>LN2 INLET JACKET</b>			
DRAWN BY <b>KRISHANPAL</b>	DATE 10/10/2016	SIZE <b>A4</b>		DRAWING NUMBER <b>80KPRECOOLER-003</b>	
CHECKED BY <b>SAMIRAN</b>	DATE 10/10/2016	SCALE 1:1			REV <b>0</b>
DESIGNED BY <b>DEVESH</b>	DATE xxx	WEIGHT(kg) 0.02		SHEET 3/10	

Note: All dimensions are in mm  
Remove all sharp edges

D

A

D

C

B

A

4

4

3

3

2

2

1

1

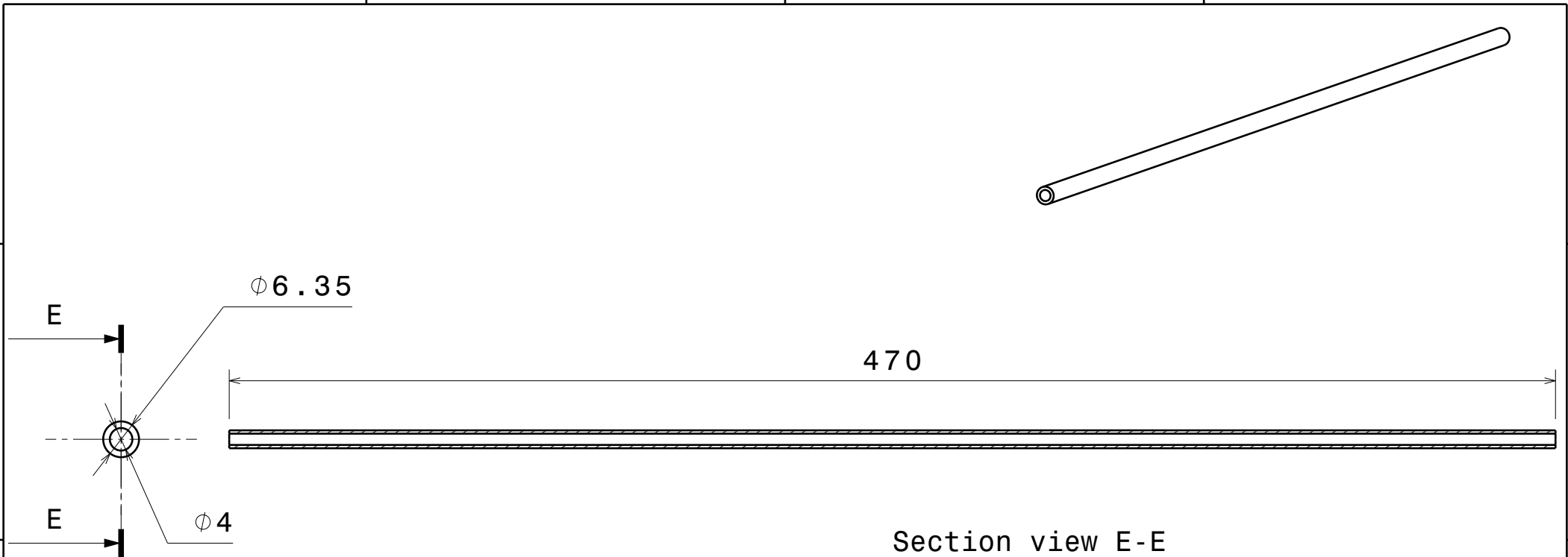

Section view E-E

MATERIAL	SS-304
QUANTITY	1

This drawing is our property.  
It can't be reproduced  
or communicated without  
our written agreement.

**INSITITUTE FOR PLASMA  
RESEARCH BHAT, GANDHINAGAR**

DRAWN BY <b>KRISHANPAL</b>		DATE 10/10/2016		DRAWING TITLE <b>LN2 INLET PIPE</b>			
-------------------------------	--	--------------------	--	--	--	--	--

CHECKED BY <b>SAMIRAN</b>		DATE 10/10/2016		SIZE <b>A4</b>	DRAWING NUMBER <b>80KPRECOOLER-006</b>		REV <b>0</b>
------------------------------	--	--------------------	--	-------------------	---	--	-----------------

DESIGNED BY <b>DEVESH</b>		DATE xxx		SCALE 1:1	WEIGHT(kg) 0.01	SHEET 6/10	
------------------------------	--	-------------	--	--------------	--------------------	---------------	--

Note: All dimensions are in mm  
Remove all sharp edges

D

A

D

C

B

A

4

4

3

3

2

2

1

1

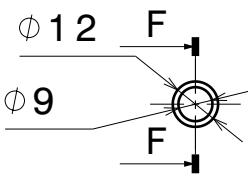
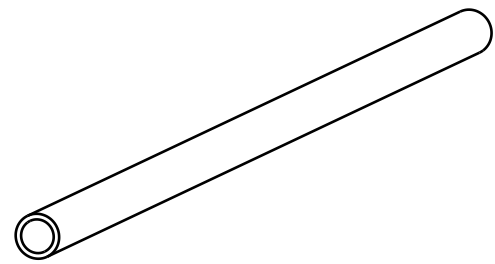

Section view F-F

MATERIAL	SS-304
QUANTITY	1

This drawing is our property.  
It can't be reproduced  
or communicated without  
our written agreement.

**INSITITUTE FOR PLASMA  
RESEARCH BHAT, GANDHINAGAR**

DRAWN BY  
**KRISHANPAL**

DATE  
10/10/2016

DRAWING TITLE  
**LN2 OUTLET PIPE**

CHECKED BY  
**SAMIRAN**

DATE  
10/10/2016

SIZE <b>A4</b>	DRAWING NUMBER <b>80KPRECOOLER-007</b>	REV <b>0</b>
-------------------	---	-----------------

DESIGNED BY  
**DEVESH**

DATE  
xxx

SCALE 1:1	WEIGHT(kg) 0.02	SHEET 7/10
--------------	--------------------	---------------

Note: All dimensions are in mm  
Remove all sharp edges

D

A



D

C

B

A

4

4

3

3

2

2

1

1

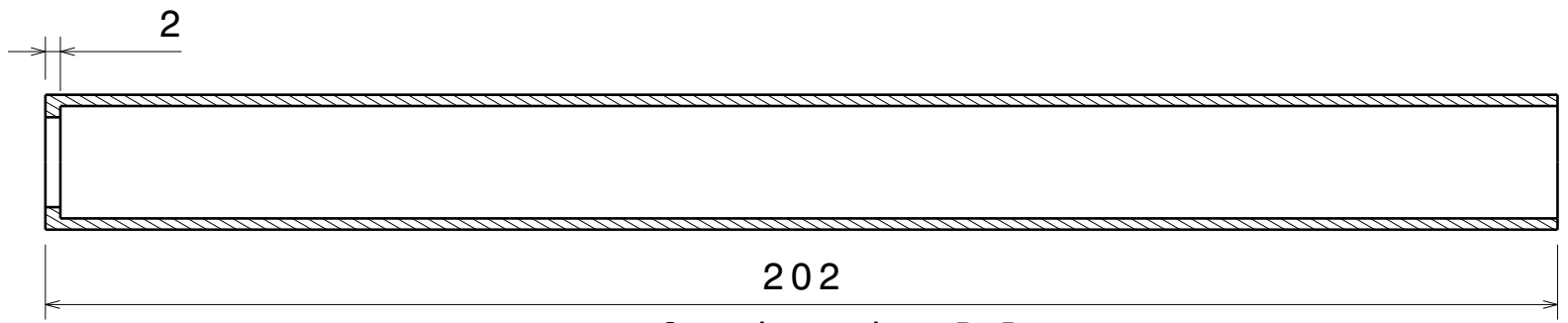
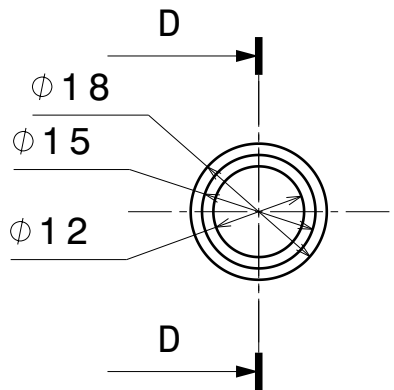
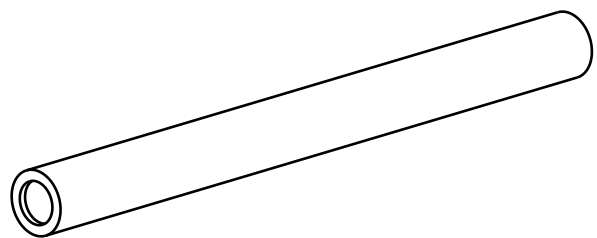

Section view D-D

MATERIAL	SS-304
QUANTITY	1

This drawing is our property.  
It can't be reproduced  
or communicated without  
our written agreement.

**INSITITUTE FOR PLASMA  
RESEARCH BHAT, GANDHINAGAR**

DRAWING TITLE  
**N2 OUTLET JACKET**

DRAWN BY  
**KRISHANPAL**

DATE  
10/10/2016

SIZE  
**A4**

DRAWING NUMBER  
**80KPRECOOLER-004**

REV  
**0**

CHECKED BY  
**SAMIRAN**

DATE  
10/10/2016

DESIGNED BY  
**DEVESH**

DATE  
xxx

SCALE  
1:1

WEIGHT(kg)  
0.02

SHEET  
4/10

Note:All dimenssions are in mm  
Remove all sharp edges

D

A

H G F E D C B A

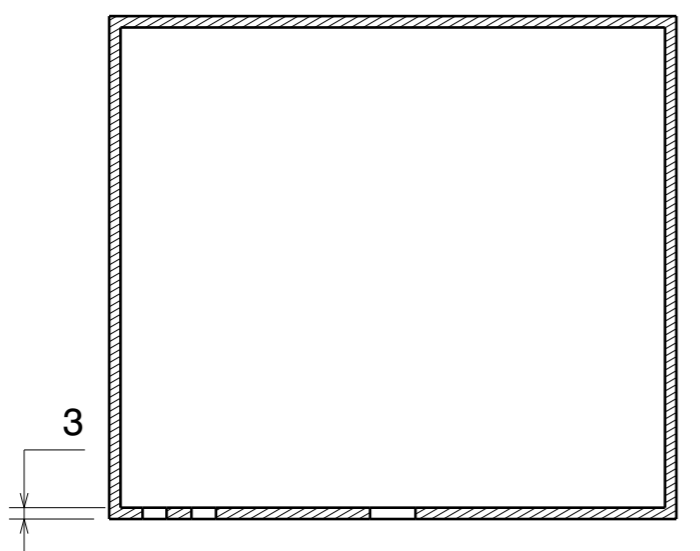
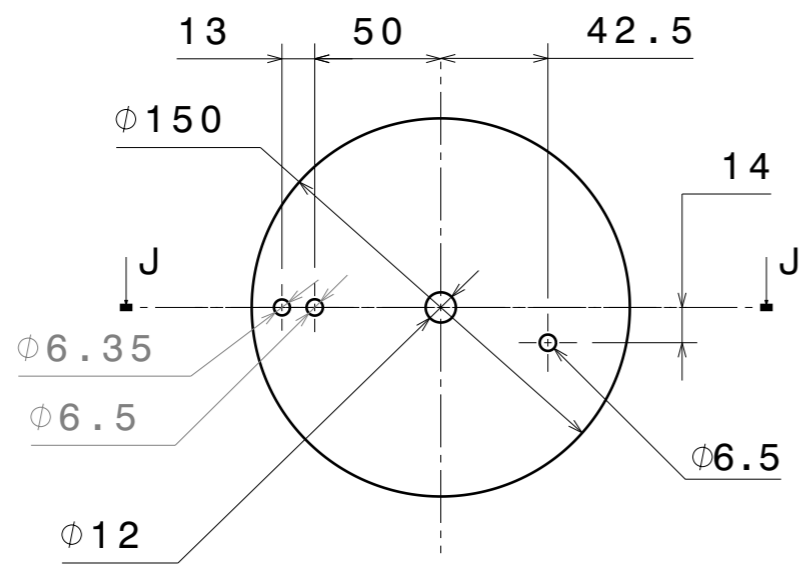
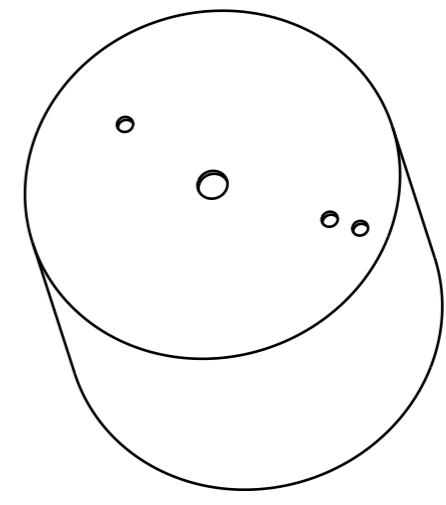
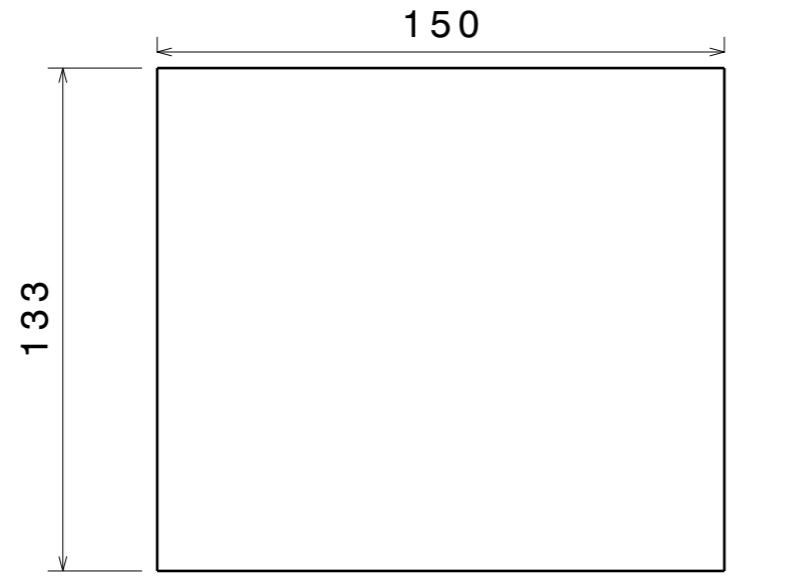

Note: All dimensions are in mm  
Remove all sharp edges

MATERIAL	SS-304
QUANTITY	1

This drawing is our property. It can't be reproduced or communicated without our written agreement.		<b>INSITITUTE FOR PLASMA RESEARCH BHAT, GANDHINAGAR</b> DRAWING TITLE <b>PRECOOLER LN2 DEWAR</b>		
DRAWN BY <b>KRISHANPAL</b>	DATE 10/10/2016			
CHECKED BY <b>SAMIRAN</b>	DATE 10/10/2016	SCALE 1:1	WEIGHT (kg) XXX	SHEET 5/10
DESIGNED BY <b>DEVESH</b>	DATE XXX			

4

4

3

3

2

2

1

1

H G F E D C B A