

Preferred assembly sequence (Annexure-1)

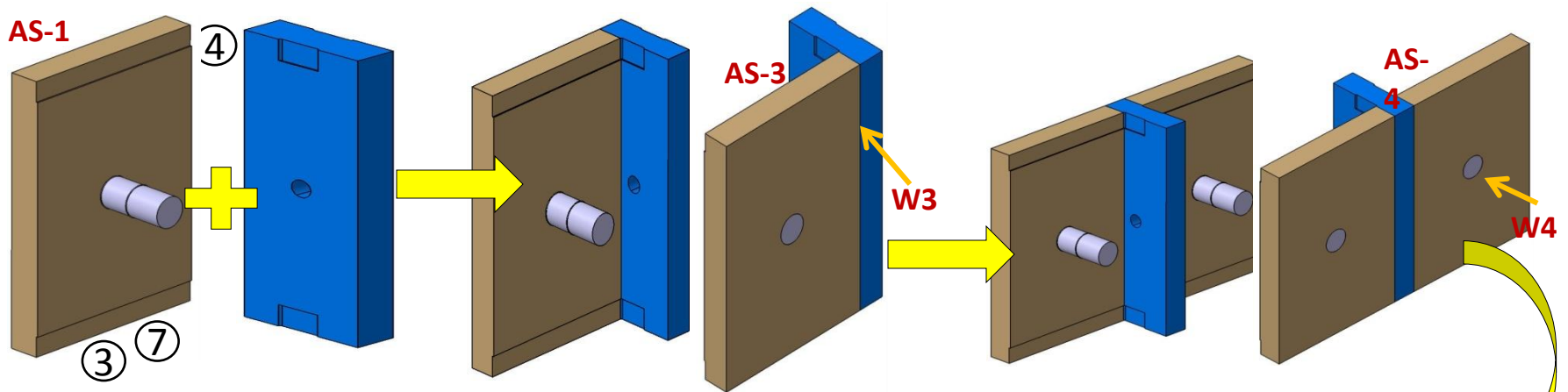

Note: Fabricator should follow the preferred assembly sequence and welding direction as shown here.

Preferred assembly sequence (Annexure-1)

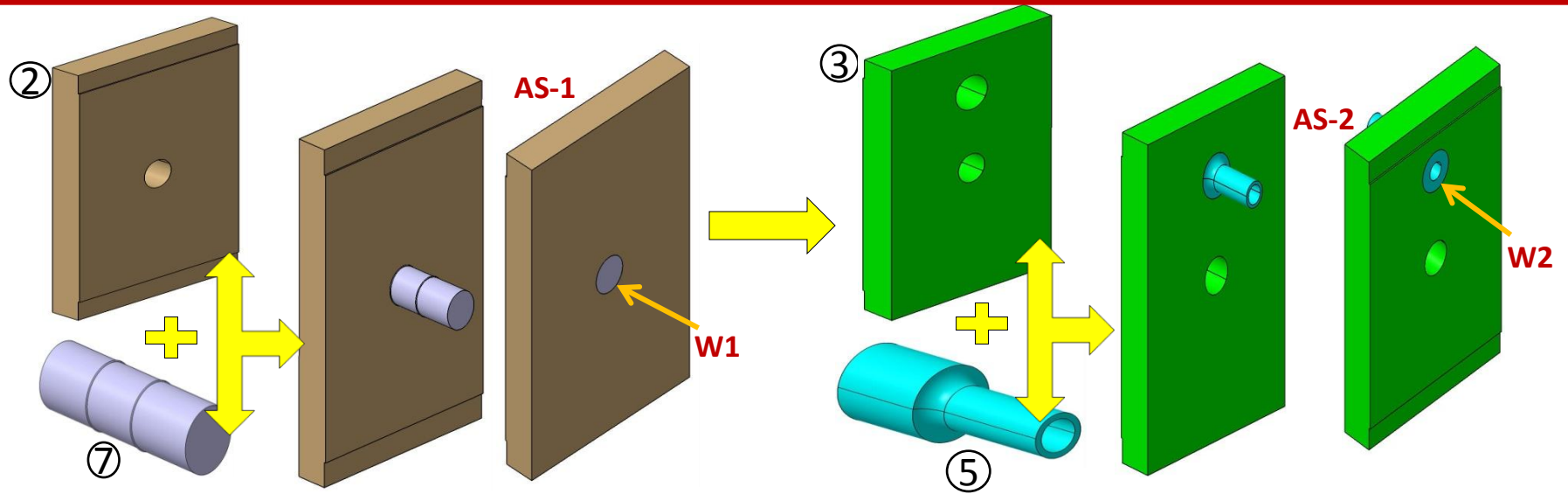
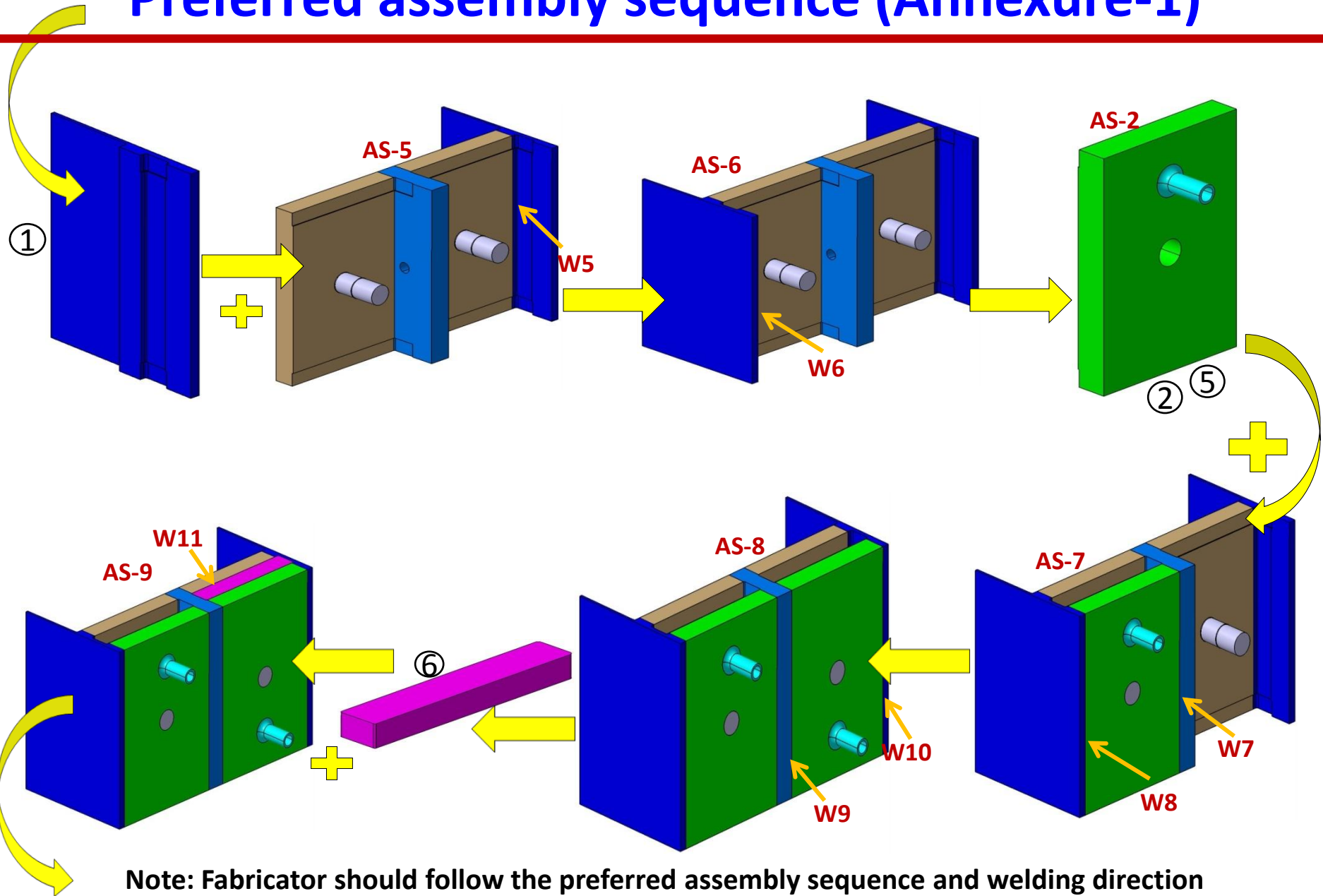

Note: Fabricator should follow the preferred assembly sequence and welding direction as shown here.

Preferred assembly sequence (Annexure-1)

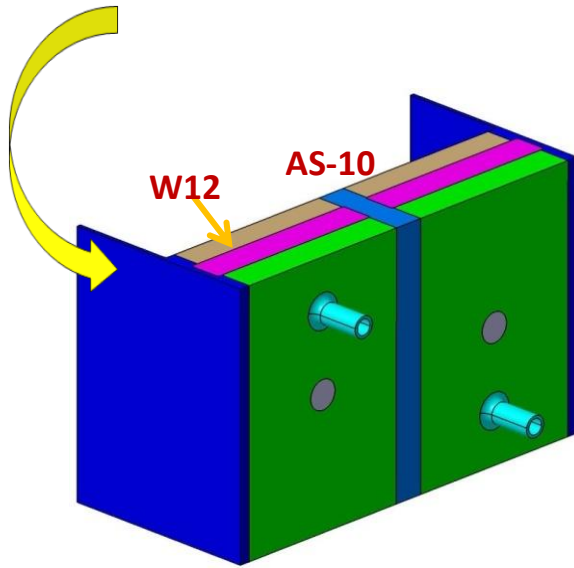

AS = Assembly sequence
W = Welding direction

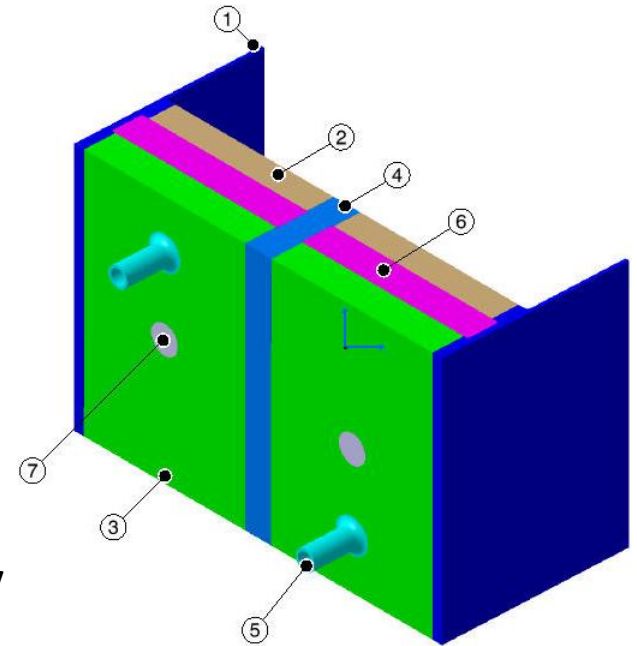

Note: Fabricator should follow the preferred assembly sequence and welding direction as shown here.

7	BKPA_IPR_01_7	STIFFNER_PIN	2	ASTM-182 F91
6	BKPA_IPR_01_6	COVER PLATE	4	ASTM-387 GR.91 CLASS 2
5	BKPA_IPR_01_5	PIPE	2	ASTM-182 F91
4	BKPA_IPR_01_4	MID PLATE	1	ASTM-387 GR.91 CLASS 2
3	BKPA_IPR_01_3	OUTER BACK PLATE	2	ASTM-387 GR.91 CLASS 2
2	BKPA_IPR_01_2	INNER BACK PLATE	2	ASTM-387 GR.91 CLASS 2
1	BKPA_IPR_01_1	SIDE PLATE	2	ASTM-387 GR.91 CLASS 2
PART NO	DRAWING NO	PART NAME	QTY.	MATERIAL