

This file has been cleaned of potential threats.

To view the reconstructed contents, please SCROLL DOWN to next page.

INSTITUTE FOR PLASMA RESEARCH  
(An Aided Institute of Department of Atomic Energy, Government of India)  
Near Indira Bridge; Bhat; Gandhinagar-382428; India

**Notice Inviting Tender  
(NIT)**

निविदा सूचना TENDER NOTICE NO: IPR/TN/PUR/TPT/ET/21-22/036  
दिनांकित DATED 30-12-2021

Head-Purchase and Stores Department, Institute for Plasma Research, for and on behalf of Director, Institute for Plasma Research (IPR) invites online tenders IN **TWO PART (INR quote only)** for execution of contract in accordance with the purchaser's tender specifications. The invitation to tender, tendering conditions, general conditions of contract, special conditions of contract and additional conditions of contract, if any, which will govern the contract pursuant to the tender are attached.

Bidders interested to submit bid are requested to go through the contents of the NIT and ensure that the bid is submitted online on or before the due date and time indicated in NIT and as per technical specifications and terms and conditions indicated herein and upload digitally signed or ink signed undertaking of Form No. **IPR-LP-ET-02.V5**.

Off line bids including hard copy in any form will not be accepted.

Head-Purchase Section  
For and on behalf of Director, IPR  
(The Purchaser)

Encl: as above.

**निविदा सूचना TENDER NOTICE NO: IPR/TN/PUR/TPT/ET/21-22/036**

**दिनांकित DATED 30-12-2021**

निम्नलिखित के लिए प्रतिष्ठित और योग्य पार्टियों से ई-निविदा विधि के माध्यम से दो भाग में ऑनलाइन निविदा आमंत्रित की जाती है।

Online tender is invited in **TWO PARTS** through e-tendering mode from reputed and eligible parties for the following.

Work/Item Description	Design, Manufacturing, Inspection, Testing, FAT, Supply and SAT of Double walled bellows at Institute for Plasma Research, Gandhinagar as per the detailed specifications mentioned in the tender documents.
Tender Fee	<b>Not Applicable</b>
Earnest Money Deposit (EMD)	Not Applicable. <b>In place of EMD, vendor should upload sealed and signed "Bid Security Declaration" as per ANNEXURE-V</b>
Publishing Date	<b>31-12-2021 at 10:00 Hrs.</b>
Document Download / Sale Start Date	<b>31-12-2021 at 10:00 Hrs.</b>
Seek Clarification Start Date	<b>31-12-2021 at 10:00 Hrs.</b>
Seek Clarification End Date	<b>11-01-2022 by 17:00 Hrs.</b>
Pre-bid Meeting Date	<b>18-01-2022 by 10.30 Hrs</b>
Response to Clarification by IPR	<b>31-01-2022 by 17.00 Hrs</b>
Bid Submission Start Date	<b>01-02-2022 at 10.00 Hrs</b>
Bid Submission Closing Date	<b>15-02-2022 at 13.00 Hrs</b>
भाग-I के ऑनलाइन खोलने का समय और तिथि (तकनीकी बोली)  Time and Date of online Opening of PART-I (Technical Bid)	<b>16-02-2022 at 14.00 Hrs</b>
भाग-II के ऑनलाइन खोलने का समय और तिथि (मूल्य बोली)  Time and Date of online Opening of PART-II (Price Bid)	<b>Will be declared later on</b>

Pre-bid meeting with the vendors will be held through Video Conference on **18/01/2022 10:30 Hrs** onwards after receipt of pre-bid queries. The interested vendors are required to register themselves for participation in the pre-bid meeting through the following link on or before: **12/01/2022**.

Link: <https://forms.gle/FLGZPGZ5DrGoYezT9>

The web link to join the scheduled pre-bid meeting through Video Conference along with password will be shared with the registered (for pre-bid meeting participation) vendors only by **13/01/2022**.

If any registered vendor had not received the link to join the video Conference they may contact the Tender Inviting officer @ [nodalofficer.et@ipr.res.in](mailto:nodalofficer.et@ipr.res.in)

It may please be noted that any clarifications required in this tender either technical or otherwise shall be carried out before submission of bids.

Detailed tender notice along with Eligibility criteria and Tender Document is available on website <https://eprocure.gov.in/eprocure/app> for free view and downloading. For participating in the e-tendering process, it is mandatory to get registered on the above e-tender portal and required to have Digital Signature Certificate (Class -III). For new registration/ tendering, bidders may go through the “**Instructions for Online Bid Submission**” provided as under.

A copy of this NIT is also available on the Institute’s website [www.ipr.res.in](http://www.ipr.res.in) . For further information, please contact: 079 23962020/2021, Fax: 079 23962277.



## **Instructions for Online Bid Submission**

The bidders are required to submit soft copies of their bids electronically on the CPP Portal, using valid Digital Signature Certificates. The instructions given below are meant to assist the bidders in registering on the CPP Portal, prepare their bids in accordance with the requirements and submitting their bids online on the CPP Portal.

More information useful for submitting online bids on the CPP Portal may be obtained at: <https://eprocure.gov.in/eprocure/app>.

### **REGISTRATION**

- 1) Bidders are required to enroll on the e-Procurement module of the Central Public Procurement Portal (URL: <https://eprocure.gov.in/eprocure/app>) by clicking on the link **“Online bidder Enrollment”** on the CPP Portal which is free of charge.
- 2) As part of the enrolment process, the bidders will be required to choose a unique username and assign a password for their accounts.
- 3) Bidders are advised to register their valid email address and mobile numbers as part of the registration process. These would be used for any communication from the CPP Portal.
- 4) Upon enrolment, the bidders will be required to register their valid Digital Signature Certificate (Class III Certificates with signing key usage) issued by any Certifying Authority recognized by CCA India (e.g. Sify / nCode / eMudhra etc.), with their profile.
- 5) Only one valid DSC should be registered by a bidder. Please note that the bidders are responsible to ensure that they do not lend their DSC's to others which may lead to misuse.
- 6) Bidder then logs in to the site through the secured log-in by entering their user ID / password and the password of the DSC / e-Token.

### **SEARCHING FOR TENDER DOCUMENTS**

- 1) There are various search options built in the CPP Portal, to facilitate bidders to search active tenders by several parameters. These parameters could include Tender ID, Organization Name, Location, Date, Value, etc. There is also an option of advanced search for tenders, wherein the bidders may combine a number of search parameters such as Organization Name, Form of Contract, Location, Date, Other keywords etc. to search for a tender published on the CPP Portal.
- 2) Once the bidders have selected the tenders they are interested in, they may download the required documents / tender schedules. These tenders can be moved to the respective 'My Tenders' folder. This would enable the CPP Portal to intimate the bidders through SMS / e-mail in case there is any corrigendum issued to the tender document.
- 3) The bidder should make a note of the unique Tender ID assigned to each tender, in case they want to obtain any clarification / help from the Helpdesk.

## PREPARATION OF BIDS

- 1) Bidder should take into account any corrigendum published on the tender document before submitting their bids.
- 2) Please go through the tender advertisement and the tender document carefully to understand the documents required to be submitted as part of the bid. Please note the number of covers in which the bid documents have to be submitted, the number of documents - including the names and content of each of the document that need to be submitted. Any deviations from these may lead to rejection of the bid.
- 3) Bidder, in advance, should get ready the bid documents to be submitted as indicated in the tender document / schedule and generally, they can be in PDF / XLS / RAR / DWF/JPG formats. Bid documents may be scanned with 100 dpi with black and white option which helps in reducing size of the scanned document.
- 4) To avoid the time and effort required in uploading the same set of standard documents which are required to be submitted as a part of every bid, a provision of uploading such standard documents (e.g. PAN card copy, annual reports, auditor certificates etc.) has been provided to the bidders. Bidders can use "My Space" or "Other Important Documents" area available to them to upload such documents. These documents may be directly submitted from the "My Space" area while submitting a bid, and need not be uploaded again and again. This will lead to a reduction in the time required for bid submission process.

**Note:** *My Documents space is only a repository given to the Bidders to ease the uploading process. If Bidder has uploaded his Documents in My Documents space, this does not automatically ensure these Documents being part of Technical Bid.*

## SUBMISSION OF BIDS

- 1) Bidder should log into the site well in advance for bid submission so that they can upload the bid in time i.e. on or before the bid submission time. Bidder will be responsible for any delay due to other issues.
- 2) The bidder has to digitally sign and upload the required bid documents one by one as indicated in the tender document.
- 3) Bidder has to select the payment option as "offline" to pay the tender fee / EMD as applicable and enter details of the instrument.
- 4) Bidder should prepare the EMD as per the instructions specified in the tender document. The original should be posted/couriered/given in person to the concerned official, latest by the last date of bid submission or as specified in the tender documents. The details of the DD/any other accepted instrument, physically sent, should tally with the details available in the scanned copy and the data entered during bid submission time. Otherwise the uploaded bid will be rejected.
- 5) Bidders are requested to note that they should necessarily submit their financial bids in the format provided and no other format is acceptable. If the price bid has been given as a standard BoQ format with the tender document, then the same is to be downloaded and to be filled by all the bidders. Bidders are required to download the BoQ file, open it and complete the white coloured (unprotected) cells with their respective financial quotes and other details (such as name of the bidder). No other cells should be changed. Once the details have been completed, the bidder should save it and submit it online, without changing the filename. If the BoQ file is found to be modified by the bidder, the bid will be rejected.

- 6) The server time (which is displayed on the bidders' dashboard) will be considered as the standard time for referencing the deadlines for submission of the bids by the bidders, opening of bids etc. The bidders should follow this time during bid submission.
- 7) All the documents being submitted by the bidders would be encrypted using PKI encryption techniques to ensure the secrecy of the data. The data entered cannot be viewed by unauthorized persons until the time of bid opening. The confidentiality of the bids is maintained using the secured Socket Layer 128 bit encryption technology. Data storage encryption of sensitive fields is done. Any bid document that is uploaded to the server is subjected to symmetric encryption using a system generated symmetric key. Further this key is subjected to asymmetric encryption using buyers/bid opener's public keys. Overall, the uploaded tender documents become readable only after the tender opening by the authorized bid openers.
- 7) The uploaded tender documents become readable only after the tender opening by the authorized bid openers.
- 8) Upon the successful and timely submission of bids (i.e. after Clicking "Freeze Bid Submission" in the portal), the portal will give a successful bid submission message & a bid summary will be displayed with the bid no. and the date & time of submission of the bid with all other relevant details.
- 9) The bid summary has to be printed and kept as an acknowledgement of the submission of the bid. This acknowledgement may be used as an entry pass for any bid opening meetings.

### **ASSISTANCE TO BIDDERS**

- 1) Any queries relating to the tender document and the terms and conditions contained therein should be addressed to the Tender Inviting Authority for a tender or the relevant contact person indicated in the tender.
- 2) Any queries relating to the process of online bid submission or queries relating to CPP Portal in general may be directed to the 24x7 CPP Portal Helpdesk.

\*\*

\*\*

## **TWO-PART TENDER SECTION – A**

### **Invitation to Tender and Tendering Conditions**

#### **1.0 INVITATION TO TENDER**

1.1 Institute for Plasma Research (IPR) invites online tenders for supply of Plant, Machinery, Equipment/Components to the specifications detailed in Section "C" to this tender document. The conditions of contract/purchase order which will govern the contract pursuant to the tender are as contained in Section "B" of this tender document. If you are in a position to quote for supply in accordance with the technical specifications indicated in Section "C" to this tender document and as per the conditions stipulated in this Section and Section B, please upload your offer in a manner and method specified below.

#### **2.0 MANNER AND METHOD FOR SUBMISSION OF TENDERS**

2.1 All tenderers in response to this invitation shall be submitted through online mode only. Tender submitted by **fax/cable/telegram or any mode other than online will NOT be considered at all** and all such tenders will be rejected without any notice to the tenderer.

2.1.1 **Part-I (Techno-commercial):** This part of the tender shall include/contain documents related to eligibility criteria, all technical details, technical specifications, drawings and also the commercial terms and conditions of contract for the supplies to be made and the services to be rendered **EXCLUDING ANY PRICE DETAILS THEREOF.**

**Proof for fulfillment of eligibility criteria mentioned in Annexure-A should be uploaded along with the tender. If the tender is submitted without valid documents, we shall not consider your offer. Tenders received without proof of eligibility criteria will be rejected. The offers which meets the eligibility criteria will only be considered for evaluation.**

2.1.2 **Part-II (Price):** This part should contain only the prices of the stores offered for the services to be rendered. Part-II (Price) should be furnished in accordance with the format provided by the Purchaser at Section "D" of this tender document

2.1.3 If tenderer includes prices of any nature in Part-I (Techno-commercial) of the tender such offers are liable for rejection without any notice to the tenderers.

#### **3.0 EARNEST MONEY DEPOSIT (EMD)**

3.1 The Tenderer shall submit, as part of its bid, interest free Earnest Money Deposit (EMD) for an amount as specified in the Tender Notice. In the case of foreign bidders, the EMD shall be submitted either by the

principal or by the Indian agent and in the case of indigenous bidders; the EMD shall be submitted by the manufacturer or their specifically authorized dealer/bidder. EMD shall be submitted by way of Demand Draft from **SBI/nationalized banks or any one of the scheduled banks mentioned in the bracket (Axis Bank, HDFC Bank, ICICI Bank and IDBI Bank)** issued in favour of "**Institute for Plasma Research**" and payable at **Ahmedabad**. **Tender received without EMD will be rejected at the discretion of IPR.**

***(Copy of Demand Draft to be uploaded with the quotation, Original DD should be sent to IPR on or before the specified closing date and time)***

- 3.2 The EMD of unsuccessful Tenderer will be discharged/returned after finalizing award of the Contract/placement of Purchase order.
- 3.3 The successful Tenderers EMD shall be discharged upon the Bidder submitting the Security Deposit as specified in the contract/purchase order, without any interest.
- 3.4 **Exemption from payment of EMD:** The firms registered with DGS&D, NSIC, DPS or Micro & Small Enterprises (MSEs) which are actual producers/manufacturers of tendered items are exempted from payment of EMD provided valid registration certificate is uploaded along with the offer. In the case of foreign bidders, payment of EMD is exempted if they submit their bid directly or through their Indian agent in **foreign currency** against the tender document bought by them, so that the order can be placed directly on their Principals.
- 3.5 **The EMD may be forfeited:**
  - 3.5.1 If a Tenderer withdraws or amends or modifies or impairs or derogates its bid during the period of bid validity specified by the Bidder on the Bid Form; or
  - 3.5.2 In case of a successful tenderer, if the tenderer fails to furnish order acceptance within 15 days of the order or fails to submit the Security Deposit within 21 days from the date of contract/order.

#### **4.0 LATE/DELAYED TENDERS**

- 4.1 Uploading of the offer document after the due date and time shall not be permitted. Time being displayed on e-Tendering portal shall be final and binding on the applicant.

#### **5.0 OPENING OF TENDERS**

- 5.1 Unless otherwise pre-opened or postponed with advance intimation to the tenderers, tender will be opened in two stages on the date and time indicated on e-Tendering portal.
- 5.2 Part-I (Techno-commercial) of the tender will be opened at the first stage on the due date and time indicated for opening on the e-Tendering portal while the Part-II (Price) will be opened at the second stage after completion of the evaluation of the Techno-Commercial Part (Part-I) of the tender.
- 5.3 While all the tenderers who uploaded tenders within the due date and time will be permitted to participate in the opening of Part-I (Techno-Commercial) of the tender on the due date and time indicated on e-Tendering portal, opening of the Part-II (Price) of the tender can be attended to only by such of those tenderers whose Part-I (Techno-Commercial) of the tenders are found to be technical suitable/

acceptable to the Purchaser and to whom intimation thereof is given by the Purchaser by Email/letter or through e-Tendering portal.

- 5.4 The tenderers whose Techno-commercial part (Part-I) are found suitable/acceptable to the Purchaser, will be given seven days advance intimation by the Purchaser to enable such tenderers to depute their representative to participate in the opening of the Part-II (Price) of the tender. The technically unqualified tenderers will neither be given any intimation about the date and time of opening of Part-II (Price) of the tender nor will they be permitted to participate in the opening of the same. **Part-II (Price) of the technically disqualified tenderers will not be opened.**

## **6.0 AUTHORITY LETTER**

- 6.1 The tenderers who wish to participate in the opening of the tenders may depute their representatives to IPR on the respective due date and time as indicated in the tender notice with an authority letter addressed to the Purchase Officer which should be produced to the officers who are opening the tenders, on demand to prove the bonafides of the representative who participates in the opening of the tender. In case the representative of the tenderer fails to produce such an authority letter on behalf of the tenderer, he will be debarred from participating in the opening of the tenders.

- 6.2 The tenderers representative, who reaches the venue of the tender opening late, i.e. after the starting time specified for opening of the tenders, may not be allowed to take part in the tender opening. It should be noted that only one representative of each tenderer will be permitted to participate in the tender opening.

## **7.0 EVALUATION OF TENDER**

- 7.1 Evaluation of tender shall be based on all inclusive landed cost.

## **8.0 PURCHASER'S RIGHTS TO REJECT QUOTATION**

- 8.1 The Purchaser reserves the right to reject any quotation without assigning any reason thereof.

## **9.0 TECHNICAL CLARIFICATIONS**

- 9.1 After opening of Part-I (Techno-commercial) of the tender, if it becomes necessary for IPR to seek clarifications from the tenderers, the same will be sought for from the tenderers.

## **10.0 DATE FOR OPENING OF PART-II (PRICE):**

After completion of technical evaluation, Part-II (Price) of only technically qualified tenderers shall be opened. The date and time of opening of Part-II (Price) shall be intimated only to the technically qualified tenderers. Whose Part-I offers have been found suitable will only be permitted to participate in the opening of the Part-II (Price) of the tender.

## **11.0 HOLIDAYS**

If the date (s) specified for receipt and opening of the tenders is/are declared as holidays abruptly by the competent authority due to any administrative reasons, then the date(s) for opening of tenders will get postponed automatically to the next working day. As for instance, if the due date for receipt of tender and its opening falls on 3<sup>rd</sup> of a particular month and if the 3<sup>rd</sup> day of the month is declared as a holiday, then the

opening date of tender will stand automatically postponed to 4th day of the month at the same time. However, due date for submission of tender online will remain same as mentioned in the tender notice.

**12.0 VALIDITY OF OFFERS**

Offers shall be kept valid for acceptance for a period of of 120 (One hundred twenty) days from the date of opening of the tender. Offers with shorter validity period will be liable for rejection.

**13.0 CATALOGUES/TECHNICAL LITERATURE**

Vendor shall upload all necessary catalogues/drawings technical literature data as are considered essential for full and correct evaluation of the offers shall invariably accompany the Part-I (Techno-Commercial) of the tender. The quotations are liable to be ignored if this condition is not complied with.

**14.0 TERMS AND CONDITIONS OF THE CONTRACT**

It must be clearly understood that any contract concluded pursuant to this invitation to tender shall be governed by the General Conditions of the Contract as contained in Section "B" of this tender document. Tenderers must therefore, take special care to go through these general conditions of contract and in exceptional cases if any deviations are proposed, these must be clearly indicated in the Part-I of the tender as a separate annexure instead of merely enclosing their printed conditions of Sale. Tenders made subject to counter conditions or far too many deviations from the general conditions of contract, i.e. Section "B" of this tender document are liable to be ignored. It should also be realised that failure to bring out deviations from the General Conditions of Contract contained in Section "B" of this tender document will imply that the tenderer is willing to execute the contract as per the Purchaser's terms and conditions of contract.

**15.0 TENDERING CONDITIONS FOR BIDS**

- 15.1 The prices quoted must be FIRM and preference will be given to such tenders. In exceptional cases (e.g. items involving substantial use of raw materials susceptible to sharp fluctuations in prices) if prices quoted subject to variation it shall be on the basis of a standard 'Price Variation Formula'. The basis for calculation shall be very clearly stated. The responsibility for furnishing the documentary evidence for price variation lies with the vendor. Here again preference will be given to the tenders with a specific ceiling on escalation.
- 15.2 Prices quoted by the tenderer should include all charges involved for direct and safe-delivery of the stores to the consignee/place of delivery indicated in the tender document. If a tenderer so desires, separate lump sum charges for safe-delivery of the stores to the consignee/purchaser's site, could be furnished. However, the purchaser reserves the right to call for break-up. The purchaser will neither undertake responsibility for transit insurance nor pay for it separately.
- 15.3 In respect of tenders on Ex-works basis, in case the tenderer has not mentioned in the offer packing, forwarding and transportation charges for safe delivery up to Purchaser's site, 2% of the price quoted towards packing (in respect of both local and outstation firms), 1% of the basic price quoted towards safe delivery charges in respect of local tenderer and 3% of the basic price quoted towards safe delivery charges in



respect of outstation firm will be added for comparison of offers on safe door delivery at Purchaser's site.

- 15.4 The stores shall neither be despatched under 'owner's risk' nor consigned to 'self', but only to the consignee's name and address indicated in the Purchase order. Non-adherence to this condition shall make the contractor liable to bear all consequential penalties/expenses such as demurrage, wharf age, etc. which the Purchaser may incur.
- 15.5 The consignee will, as soon as possible, but not later than 45 days from the date of arrival of stores at destination notify the contractor of any loss or damage to the stores that may have occurred during transit to enable the contractor to repair/rectify the defects/damages or replace the goods as is appropriate, free of all charges. In case it is desired by the contractor for returning of the material to them all expenses towards transportation etc. will be borne by the supplier and also will furnish bank guarantee towards the cost of material.
- 15.6 In case an Indian supplier/Agent furnishes an offer for supply of out-rightly imported stores, the price of such stores shall be quoted in Indian Rupees for delivery to the consignee's premises exclusive of import duties and on firm price basis.
- 15.6 **Conditional Discount:** In case the tenderer offers any conditional discount with regard to acceptance of their offer within a specific payment terms, delivery, quantity etc. the purchaser will not take into consideration such conditional discount while evaluating their offer.

## **16.0 SPARES AND ACCESSORIES**

- 16.1 Tenders for plant/machinery/equipment/component shall also indicate prices for essential accessories, optional accessories and spares necessary for satisfactory operation of the plant/machinery/equipment.
  - 16.1.1 for a period of two years and
  - 16.1.2 for a period of five years
- 16.2 Prices for accessories and spares shall be itemized. Tenders where only lumpsum prices are indicated are liable to be ignored. Particular care must be taken to list out each item of spare and quantity recommended and also the individual price for these items. These details should be included only in Part-II (Price) of the tender. However, a list of spares and accessories without Price should be included in Part-I (Techno-Commercial) of the tender.

## **17.0 QUANTITY**

The purchaser reserves the right to accept tenders for any quantity of his choice and the tenderer shall be bound to accept a contract for any quantity. The Purchaser also reserves the right to accept or reject lowest or any tender in full or in part without assigning any reasons.

## **18.0 STATUTORY LEVIES SUCH AS CUSTOMS DUTY, GOODS AND SERVICE TAX**

### **18.1 CUSTOMS DUTY**

- 18.1.1 The Purchaser is entitled for assessment of customs duty at the concessional rate as per Customs Notification No. 51/96-Custom dated 23.7.1996 issued by the Department of Revenue, Ministry of Finance, as amended from time to time, in respect of purchases made for the Research Institutions under the Department of Atomic Energy and the Purchaser will obtain the requisite



- certificate from the appropriate authority.
- 18.1.2 In case an Indian vendor/agent submits an offer for supply of outrightly imported stores in Indian Rupees, they should quote price for free and safe delivery of stores at destination.
- 18.1.3 Wherever, against a requirement, both indigenous as well as imported offers are received, the offers for imported stores will be evaluated on the basis of the total landed cost after loading the custom duty and other levies as may be applicable from time to time for taking purchase decision.
- 18.1.4 High Seas sale will not be considered.

**18.2 FLUCTUATION IN THE CUSTOMS DUTY**

- 18.2.1 Unless otherwise specifically agreed to in terms of the Contract, the purchaser shall not be liable for any claim on account of fresh imposition and /or increase in Customs Duty on raw materials and/or components used directly in the manufacture of the contracted stores, taking place during the pendency of the contract.

- 18.3 Offers from Indian Agents on behalf of foreign suppliers:** In case the tender is submitted by an Indian supplier/Indian agent on behalf of their foreign supplier/ principals, following documents should be submitted with the tender, failing which, their offer is liable to be ignored.

- 18.3.1 Photocopy of the Agency Agreement between the Principals and the Indian Agent showing the percentage or the quantum of agency commission payable and a Letter of Authority from the Principals authorizing the Indian Agents to submit the tender on their behalf.
- 18.3.2 The type and nature of after sales services to be rendered by the Indian Agent.
- 18.3.3 Both Indian Agent and Principal/OEM cannot bid simultaneously for the same item/product in the same tender.
- 18.3.4 The Indian Agents are allowed to quote on behalf of only one foreign Principal/ Supplier against this tender.
- 18.3.5 Copy of Registration Certificate with DGS&D or DPS.

**18.4 GOODS AND SERVICE TAX**

- 18.4.1 GOODS AND SERVICE TAX where legally leviable as per relevant HSN code will be admitted and reimbursed at the rate applicable during original delivery date.
- 18.4.2 GOODS AND SERVICE TAX intended to be claimed should be distinctly shown separately along with the price quoted. Where this is not done, no claim for GOODS AND SERVICE TAX will be admitted at any later stage and on any ground whatsoever.
- 18.4.3 The Purchaser is entitled for assessment of GST at the Concessional rate as per Notifications issued by the Government, as amended from time to time, in respect of purchases made for the Research and Development applications under the Department of Atomic Energy and other R&D units.
- 18.4.4 **GST for R&D Unit:** Goods and Service Tax (GST) wherever applicable will be paid extra at actual during the delivery period stipulated in the Purchase order. In terms of notifications issued by the Central Government and State Governments, R&D units of Department of Atomic Energy are entitled for IGST @ 5% or CGST @ 2.5% and SGST @ 2.5% as applicable for stores covered under the Purchase Order.

- 18.4.5 **GST for Services:** As applicable. Specify the SAC codes wherever services are involved.
- 18.4.6 It would be the responsibility of the contractor to ensure that relevant certificate is obtained from the Purchaser before effecting the delivery of goods ordered failing which the excess tax paid by the contractor shall not be reimbursed by the Purchaser.
- 18.4.7 When GOODS AND SERVICE TAX is claimed as extra by the vendor in general and on packing charges in particular, the following certificates should be submitted by the vendor to the Paying Authority on the bills itself.
- 18.4.8 Certified that the goods and packing charges on which GOODS AND SERVICE TAX has been charged have not been exempted under the Central Sales Tax or the State Sales Tax Act or the rules made there-under and the amount charged on account of GST on these goods and packing charges are not more than what is payable under the provision of relevant Act or the rules there-under.
- 18.4.9 Certified further that we have actually paid GOODS AND SERVICE TAX and are being assessed to GST on packing charges and also that where there are statutory exemption under the Relevant Act/Law of the State Government concerned, we have availed ourselves of it and certified non-availability of such a provision for GST on packing charges wherever claimed.
- 18.4.10 Certified further in respect of amount claimed into the bill no claim is pending for refund/or admissible. Certified that in the event of our getting refund in whole or in part of the element of GOODS AND SERVICE TAX on packing charges claimed from Government, we shall pass on the benefit to the Purchaser by remitting to Government the amount equivalent to the amount of refund obtained by us.
- 18.4.11 Further certified that we abide by the all the provisions of Acts of Governemnt and rules made thereunder especially regarding anti-profiteering provisions.
- 18.4.12 Certified further that we (our Branch or agent) \_\_\_\_\_  
 \_\_\_\_\_  
 (address) are registered as dealers in the State of \_\_\_\_\_  
 under Local Regn. No. \_\_\_\_\_ and in the State of \_\_\_\_\_  
 under Central Regn. No. \_\_\_\_\_ for the  
 purpose of State/Central Tax.  
 (Stamp & Signature of the Vendor)
- 18.4.13 The vendor shall solely be responsible for declaration of Goods and Service Tax made in his invoice and shall indemnify the purchaser from any claim or its liability from concerned authorities at any stage.
- 18.4.14 Certificate with each bill to the effect that no refund has been obtained in respect of the reimbursement of GST made to vendor during three months immediately preceding the date of the claim covered by the relevant bill.
- 18.4.15 AN UNDERTAKING to the effect that in case any refund of GST is granted to the vendor by concerned authorities in respect of stores supplied under the contract, they shall pass on the credit to the purchaser immediately alongwith a certificate from their Director/Manager/Proprietor/ Accountant to the effect that the credit so passed on relates to the GST originally paid for the stores

supplied under the contract. In case of their failure to do so within 10 days of the issue of the refund orders to them by the Authorities, the purchaser would be empowered to deduct a sum equivalent to the amount refunded by the authorities without any further reference to the vendor, from any of their outstanding bills against this or any other pending Government Contracts and that no dispute on this account would be raised by the vendor.

18.4.16 Statutory Deductions, as applicable shall be made from the supplier's bill.

#### 18.5 **DEDUCTION OF TAX AT SOURCE (TDS)**

As per Government of India rules, it is mandatory that income tax shall be deducted at source at applicable rates as per relevant act, rules and notifications issued by the government from time to time.

18.5.1 **In case of Indigenous Vendors** (Indian Suppliers who provide indigenous products and services, Indian subsidiaries with permanent establishment in India who supply imported goods and services and paid in Indian currency only): Tax deducted at source will be applicable under Section 194-C for carrying out any work (including supply of labour for carrying out any work) in pursuance of contract as per Income Tax Act 1961. In case of technical or professional services, TDS will be applicable as per under Section 194-J of Income Tax Act 1961.

18.5.2 **In case of Foreign Vendors** (Foreign Suppliers who provide goods from abroad paid in foreign currency and providing technical services by Indian subsidiary paid in Indian currency): The TDS is applicable where services are rendered in India directly or through their Indian counter part against foreign Purchase order / Contract as per the provision of under Section 195 of Income Tax act of India. Wherever DTAA (Double Taxation Avoidance Agreement) agreement exists between India and the supplier country the provisions of the agreement shall be applicable. For getting benefit of DTAA (Double Taxation Avoidance Agreement), the following documents must be submitted, otherwise full TDS will be deducted.

- a) No Permanent Establishment in India certificate
- b) Tax Residency Certificate (TRC) issued by Tax authorities of their country
- c) Form 10F if TRC does not contain required details
- d) PAN (Permanent Account Number) details issued by Indian Income Tax Authority

#### **Important Note:**

- a) Where bifurcation is inappropriate and unacceptable for supply of material and providing services the purchase order / contract will be treated as **Composite Contract** and TDS will be deducted on whole contract / purchase order value as per applicable rate.
- b) TDS or any other leviable taxes or duties, if applicable, shall be deducted recovered from the Supplier's bill and necessary certificate will be issued to the supplier.

- c) Details on relevant sections of Income Tax Act and DTAA treaties can be obtained from [https://www.incometaxindia.gov.in/ Pages/acts/income-tax-act.aspx](https://www.incometaxindia.gov.in/Pages/acts/income-tax-act.aspx).

**19.0 FLUCTUATION IN STATUTORY LEVIES**

Unless otherwise specifically agreed to in terms of the Contract, the purchaser shall not be liable for any claim on account of fresh imposition and/or increase in statutory levies on raw materials and/or components used directly in the manufacture of the contracted stores, taking place during the pendency of the contract. However, any reduction in statutory levies on these raw materials and/or components must be passed on to the Purchaser.

**20.0 SAMPLES/PROTOTYPES**

If any called for shall be submitted free of all charges by the Tenderer and the Purchaser shall not be responsible for any loss or damage thereof for any reason whatsoever. In the event of non-acceptance of the tender, the tenderer will have to make arrangements to remove/collect the sample/prototypes at his own expenses.

**21.0 QUANTITIES**

Quantities indicated are approximate only and one or more of the items of the stores tendered, or a portion of any one or more of the items of such stores may be accepted and the tenderer notwithstanding that his Tender has not been accepted in whole shall be bound to supply contracted quantity to the Purchaser.

**22.0 SUBMISSION OF DRAWINGS**

The tenderer shall furnish all drawings pertaining to the plant/machinery/ equipment/component to the Purchaser along with the tender for correct understanding and appreciation of the tender in quadruplicate. Besides, tenderers should also furnish general arrangement, schematic and such other drawings prescribed by the Purchaser within 4 weeks from the date of receipt of a Purchase Order for approval. Such drawings should be furnished along with Part-I (Techno-Commercial) of the tender. Tenderer's drawing will form part of the purchase order/contract only after these are approved by the Purchaser.

**23.0 INSTALLATION AND COMMISSIONING**

- 23.1 Wherever, the purchaser's invitation to tender calls for installation and commissioning or supervision of installation and commissioning of the instrument/equipment by the tenderer, the tenderer must clearly and separately quote the prices for the supply of the stores and the charges and the terms for installation and commissioning or supervision of installation and commissioning, as the case may be. The charges towards installation and commissioning should not be included in the price of the stores.
- 23.2 In respect of contracts involving installation and commissioning by vendors including overseas vendors where identifiable charges for the same has been quoted by the vendor, he shall bear the Income-tax liability as per the rates prevailing at the time of undertaking the job in accordance with the Income-tax Act in force in India.

23.3 Wherever, the scope of the contract includes installation and commissioning, it shall be the sole responsibility of the contractor to undertake the installation and commissioning as and when called for, by the Purchaser.

24.0 **INSPECTION**

24.1 The Contractor shall be responsible for and perform all inspection and testing required in accordance with the contract/purchase order and specifications included therewith.

24.2 The Purchaser may at his option depute his representative for inspection of the stores to be supplied under the contract or authorize and nominate a Quality Surveillance Agency of his choice for the purpose hereinafter called, in either case, the inspection.

24.3 The supplier shall give notice of readiness for inspection to the Purchaser so that the Inspector can be present at the requisite time. In such an event delivery shall not be effected until an authorization or shipping release is obtained from the Purchaser.

24.4 The contractor shall allow reasonable facility and free access to his work/factory and records to the inspector for the purpose of inspection or for ascertaining the progress of delivery under the contract.

25.0 **FACTORY REGISTRATION/SHOP & ESTABLISHMENT CERTIFICATE**

The tenderers shall upload the copy of the Factory Registration/License or Shop & Establishment Certificate as applicable, along with the tender, failing which the tenders are liable for rejection.

26.0 **PRODUCTS WITH ISI MARK**

26.1 Products with ISI mark will be preferred.

26.2 In respect of following categories of item, Purchaser will consider offers for products with ISI mark only:

- Fire Extinguisher
- Building Material
- PVC Pipes & fittings
- Agricultural Implements & sprayers
- Medical instruments such as syringes, needles, BP apparatus etc.

27.0 **SHOP/FACTORY EVALUATION, QUALITY SURVEILLANCE /INSPECTION AND SUBMISSION OF PROGRESS REPORTS**

27.1 The Purchaser or his technical authorities may at his option and prior to evaluation of the tender depute his Inspector or any quality surveillance Agency of his choice to the factory/workshop of the tenderer to assess and establish the manufacturing capability etc. of the tenderer. Similarly, the Purchaser may also depute his inspector/Quality Surveillance agency of his choice for inspection of the plant/machinery/equipment/component during the various stages of manufacture in such an event the tenderer/contractor shall:-

27.1.1 Allow reasonable facility and free access to his factory/work/ records to the Inspector for the purpose of inspection or for ascertaining the progress of manufacture and delivery.

27.1.2 Provide the drawings, toolings, gauges, instruments etc. required for carrying out the inspection work.

- 27.1.3 Produce an inspection plan to the Purchaser's satisfaction notifying him when check points on the plan are imminent.
- 27.1.4 Not supply or deliver the plant/machinery/equipment/ component unless and until a Shipping Release or an authorisation for despatch is obtained in a format provided by the Purchaser. Failure to comply with this instruction will not only result in withholding of the payment to the contractor/supplier, but also hold the tenderer/contractor liable for payment of compensation to the Purchaser due to delay in clearance of the Equipment/plant/machinery/ component from the carriers.

**28.0 INSTRUCTION MANUAL**

In respect of plant/ machinery/ equipment/ instrument/ apparatus, where instruction/ operation manual is normally necessary to enable the user to put the plant/machinery/equipment/instrument/ apparatus to proper use, the Contractor shall furnish such an instruction/operation manual specific to the stores being supplied along with the plant/machinery/equipment/instrument/apparatus. The Contractor shall clearly specify in the offer about his readiness to supply instruction/operation manual

**29.0 PACKING**

- 29.1 Tenderers shall note that packing for shipment shall be in accordance with the instructions outlined in this tender document, each package shall be limited to the size and weights that are permissible under the existing Air and Sea limitations. Even when no packing specification is included in the invitation to tender, it will be Supplier's responsibility to provide appropriate packing depending upon the nature of the supply and the transportation and handling hazards.
- 29.2 The equipment shall be so packed and protected as not to suffer deterioration, damage or breakage during shipment and storage in a tropical climate.
- 29.3 Each package shall be properly labeled to indicate the type and quantity of material it contains, the purchase order number, its dimensions and weight and any other necessary data to identify the equipment and relate it to contract.

**30.0 DEVIATIONS TO PURCHASER'S SPECIFICATIONS AND CONDITIONS OF CONTRACT**

- 30.1 If any deviation or substitution from the technical specifications contained in Section "C" to this tender document is involved, such details should be clearly indicated in Part-I (Techno-Commercial) and should be added as an annexure to Part-I (Techno-commercial) of the tender as otherwise it shall be an admission on the part of the tenderer that he will supply the equipment as specified by the Purchaser. Similarly, deviations to the Purchaser's General Conditions of Contract/Special Conditions of Contract contained in Section "B" of this tender document shall be indicated by the tenderer in another annexure to Part-I (Techno-commercial) of the tenderer.

30.2 Part-II (Price) should be furnished in accordance with the format provided by the Purchaser at Section “D” of this tender document.

**31.0 DELIVERY**

Tenderer should note that no tender will be considered by the Purchaser unless the Tenderer can meet the delivery schedule specified by the Purchaser. All equipments/machinery/plant/ component covered by this tender document should be supplied on or before \_\_\_\_\_ or \_\_\_\_\_ month from the date of approval of drawings or \_\_\_\_ month from the date of receipt of free issue materials. The prices quoted by the tenderer should include all charges involved for direct and safe delivery of the items by Road to the project site of the Purchaser. If a tenderer so desires/separate lumpsum charges for transportation and safe delivery to Purchaser’s site could be furnished. Purchaser will neither undertake responsibility for transit insurance nor pay for it separately. No other, delivery term will be accepted by the Purchaser.

**32.0 ACCEPTANCE OF TENDERS**

32.1 The purchaser shall be under no obligation to accept the lowest or any other tender and shall be entitled to accept or reject any tender in part or full without assigning any reasons whatsoever.

32.2 Acceptance of tenders by the Purchaser will be sent by fax, E-mail, letter etc. within the validity date of the tender and such a fax, letter etc. would then be followed by a formal purchase order/contract. The tenderer whose offer is accepted will proceed with the execution of the contract on the basis of such advance acceptance of tenders without waiting for a formal purchase order/contract, and will be responsible to seek and obtain whatever clarifications that are necessary from the Purchaser to proceed with the manufacture without waiting for a formal purchase order/contract and delivery period will be reckoned from the date of the Letter of Intent.

**33.0 SETTLEMENT OF COMMERCIAL TERMS AND CONDITIONS OF CONTRACT**

In case the commercial terms and conditions of sale/contract stipulated in Part-I (Techno-commercial) of the tender submitted by the tenderer are at variance with the Purchaser’s General Conditions of all Contracts/Special Conditions of Contract stipulated in Section “B” of this tender document, the Purchase Officer will settle the commercial terms and conditions of contract with the tenderers chosen for award of the contract by holding discussions with them OR by sending Fax/Letter/E-mail etc. In case the concerned tenderer to whom an intimation thereof is given does not respond/fail to respond to communication sent by the Purchaser within the date specified, his tender is liable for rejection at the discretion of Director, IPR and no complaints whatsoever will be entertained from the tenderer for rejection of this tender. The tenderers should not discuss with the technical authorities/user department any of the commercial terms and conditions of contract and any agreement/understanding reached between the tenderer and the technical authorities will not be valid and binding.

34.0 **COMPLIANCE WITH THE SECURITY REQUIREMENTS OF THE PURCHASER**

The Contractor shall strictly comply with the Security Rules and Regulations of the Purchaser in force and shall complete the required formalities including verification from Police and any other authority and obtain necessary prior permission for entry into the Purchasers premises, wherever authorized by the Purchaser.

35.0 **PAST PERFORMANCE**

In case the past performance of the tenderer is not found to be satisfactory with regard to quality, delivery, warranty obligation and non-fulfillment of terms and conditions of the contract, their offer is liable to be rejected by the purchaser.

36.0 **CAPACITY & FINANCIAL STANDING**

In case it is found that the tenderer does not possess the requisite infrastructure, capacity, capability and their financial standing is not satisfactory, such tender is liable to be rejected by the Purchaser.

37.0 **CONFIDENTIALITY**

Drawings, specifications, prototypes, samples or any other correspondence/details/information provided by the Purchaser relating to the tender or the contract shall be kept confidential by the contractor, and should not be disclosed or passed on to any other person/firm without the prior written consent of the purchaser. This clause shall apply to the sub-contractors, consultants, advisers or the employees engaged by the Contractor.

38.0 **RESTRICTED INFORMATION CATEGORIES UNDER SECTION 18 OF THE ATOMIC ENERGY ACT, 1962 AND OFFICIAL SECRETS UNDER SECTION 5 OF THE OFFICIAL SECRETS ACT, 1923**

Any contravention of the above mentioned provisions by the contractor, sub-contractor, consultant, adviser or the employees of the contractor will invite penal consequences under the aforesaid legislation.

39.0 **PROHIBITION AGAINST USE OF THE NAME OF ANY INSTITUTION OF DEPARTMENT OF ATOMIC ENERGY WITHOUT PERMISSION FOR PUBLICITY PURPOSES**

The Contractor or sub-contractor, consultant, adviser or the employees engaged by the contractor shall not use the name of any Institution of Department of Atomic Energy for any publicity purpose through any public media like Press, Radio, TV or Internet without the prior written approval of the Purchaser.

40.0 **FREE ISSUE MATERIAL** *(This clause shall apply only to contracts for supply of fabricated equipment with purchaser's Free Issue Materials (FIM)).*

40.1 Wherever contracts envisage supply of Free Issue Material (FIM) by the Purchaser to the contractor, such Free Issue Material shall be safeguarded by an insurance policy to be provided by the Contractor at his own cost for the full value of such materials and the insurance policy shall cover, the following risks specifically and shall be valid for six months beyond the contractual delivery date.



- **Risk to be covered:** Any loss or damage to the Purchaser's material due to fire, theft, riot, burglary, strike, civil commotion, terrorist act, natural calamities etc. and any loss or damage arising out of any other causes such as other materials falling on purchaser's materials.
- **Insured by:** (Name of the Contractor)
- **Beneficiary:** Institute for Plasma Research, Near Indira Bridge, Bhat, Gandhinagar-382428.
- **Amount for which insurance policy to be furnished:** The amount will be indicated in the respective contract.

Free Issue Material (FIM) will be issued to the Contractor only after receipt of the Insurance Policy from the Contractor. The contractor shall arrange collection of the FIM from the Purchaser's premises and safe transportation of the same to his premises at his risk and cost.

Notwithstanding the insurance cover taken out by the Contractor as above, the contractor shall indemnify the purchaser and keep the Purchaser indemnified to the extent of the value of free issue materials to be issued till such time the entire contract is executed and proper account for the FIM is rendered and the left over/surplus and scrap items are returned to the Purchaser. The contractor shall not utilize the Purchaser's free issue materials for any job other than the one contracted out in this case and also not indulge in any act, commission or negligence which will cause/result in any loss/damage to the Purchaser and in which case, the Contractor shall be liable to the Purchaser to pay compensation to the full extent of damage/loss. The Contractor shall be responsible for the safety of the free issue materials after these are received by them and all through the period during which the materials remain in their possession/control/ custody. The free issue materials on receipt at the Contractor's works shall be inspected by them for ensuring safe and correct receipt of the material. The Contractor shall report the discrepancies, if any, to the Purchaser within 5 days from the date of receipt of the material. The Contractor shall take all necessary precautions against any loss, deterioration, damage or destruction of the FIM from whatever cause arising whilst the said materials remain in their possession/custody or control. The FIM shall be inspected periodically at regular intervals by the Purchaser for ensuring safe preservation and storage. The contractor shall also not mix up the FIM with any other goods and shall render true and proper account of the materials actually used and return balance remaining unused material on hand and scrap along with final product and if it is not possible within a period of one month from the date of delivery of the final product covered by this purchase order. The Contractor shall also indemnify the Purchaser to compensate the difference in cost between the actual cost of the FIM lost/damaged and the claim settled to the Purchaser by the insurance company. The decision of the Director, Institute for Plasma Research, as to whether the Contractor has caused any loss, destruction, damage or deterioration of the FIM while in his possession, custody or control from

whatever cause arising and also on the quantum of damage suffered by the government, shall be final and binding upon the Contractor.

**41.0 EXPORT LICENCE/EXPORT PERMISSION**

41.1 It is entirely the responsibility of the vendors who are quoting for materials of foreign origin to ensure obtaining export permission/licence/authorisation as required from the respective Government before arranging shipment. This Department would not accept post supply inspection by any agency/authority of any foreign country. It is, therefore, necessary that the vendors offering materials from foreign countries shall have thorough knowledge of export contract regulations in vogue in those countries.

41.2 The vendors shall indemnify the purchaser against any consequences in respect of any end-use declaration they/their overseas Principals may furnish to the government/government agencies of the country of origin of the materials, while seeking export permission/licence. Post supply inspection, contrary to the terms and conditions of purchaser's contract shall be deemed to be null and void.

**42.0 END USE CERTIFICATE**

42.1 Whenever an End-use Certificate is desired by the vendor, the same shall be clearly mentioned in the quotation and the purchaser shall provide an Enduser Certificate as per the format given below. The Purchaser will not provide any other document/declaration in this regard.

**END USER STATEMENT:**

*"We hereby certify that the item/s i.e. \_\_\_\_\_, being procured from M/s \_\_\_\_\_ against our Purchase Order No. \_\_\_\_\_ dated \_\_\_\_\_ will be used for \_\_\_\_\_. We also certify that the item/s will not be used in designing, developing, fabricating or testing of any chemical, biological, nuclear, or weapons of mass destruction or activities related to it. It is further certified that we will not re-export the Item/s prior to obtaining permission from the concerned authorities as may be required".*

**43.0 COUNTRY OF ORIGIN**

43.1 Wherever the tenders are for imported stores, the Country of Origin of the stores must be clearly specified in the quotation.

**44.0 LIABILITY**

44.1 Vendors shall be liable for any damage to the purchaser or any third party out of any patent or latent defect in the goods supplied by him or sub-standard services rendered by him.

**45.0 RIGHT TO REJECT QUOTATION**

45.1 The Purchaser reserves the right to reject any quotation, which is not in conformity with the above instructions.

45.2 The Purchaser also reserve the right to reject any quotation without assigning any reason whatsoever.

46.0 **PRICE / PURCHASE PREFERENCE**

Purchase/Price preference to industries will be given as per the policy of the Government of India in force at the time of evaluation provided their offer is in compliance with the conditions of the policy.

47.0 **PERMANENT ACCOUNT NUMBER (PAN)**

47.1 Vendors are required to upload a true copy of the PAN Card/Letter issued by the Income-tax Department, failing which the tenders are liable to be rejected.

48.0 MSE bidders should declare their UAM (Udyog Aadhar Memorandum) number on CPPP portal to avail benefits as per Public Procurement Policy for MSE's order 2012.

49.0 The bidder shall not be under a declaration of ineligibility for corrupt or fraudulent practices or blacklisted with any of the Government Agencies.

Any additional conditions attached to this Invitation to Tender shall also form part of the contract conditions.

**SECTION 'B'**

**GENERAL CONDITIONS OF  
CONTRACT**

**INSTITUTE FOR PLASMA RESESARCH  
PURCHASE SECTION**

**GENERAL CONDITIONS OF ALL  
CONTRACT**

**&**

**SPECIAL CONDITIONS OF CONTRACT  
GOVERNING SUPPLIES OF  
PLANT AND MACNHINERY**

## **GENERAL CONDITIONS OF CONTRACT**

### **1. DEFINITIONS**

- 1.1 The term 'PURCHASER' means the Institute for Plasma Research or its successors or assigns.
- 1.2 The term 'PARTICULARS' means the following:
  - 1.2.1 Specification
  - 1.2.2 Drawing
  - 1.2.3 Sealed pattern denoting a pattern sealed and signed by the Inspector
  - 1.2.4 Proprietary make denoting the produce of an individual firm
  - 1.2.5 Any other details governing the construction manufacture and/or supply as existing for the contract.
- 1.3 The term 'CONTRACTOR' or 'SUPPLIER' means, firm or company with whom or with which the order for the supply of stores is placed and shall be deemed to include the Contractors/Successors (approved by the Purchaser), representatives, heirs, executors and administrators unless excluded by the contract.
- 1.4 The term 'CONTRACT' or 'PURCHASE ORDER' means and comprises of a Letter or Email or ink signed or digitally signed document conveying acceptance of Contractor's offer and invitation to tender, tender containing offer, advance acceptance of offer, general and special conditions of contract specified in the acceptance of offer and any subsequent amendments/alterations thereto made on the basis of mutual agreement.
- 1.5 The term 'STORES' or 'MATERIAL' means, the goods specified in the contract/purchase order which the contractor has agreed to supply under the contract.
- 1.6 The term 'SUB-CONTRACTOR' or 'SUB-SUPPLIER' means any contractor or supplier engaged by the contractor or the supplier with the prior approval of the Purchaser in relation to the contract/purchase order.
- 1.7 The term 'INSPECTOR' or 'QUALITY SURVEYOR' means any person nominated and deputed by the purchaser or their appointed Consultants or Quality Surveillance Agency or any other person from time to time authorized by the Purchaser to act as his representative for the purpose of inspection of stores under the contract/purchase order.

### **2. AUTHORITY OF PERSON SIGNING THE CONTRACT ON BEHALF OF THE CONTRACTOR**

The person signing the contract or the purchase order or any other document in respect of the contract or purchase order on behalf of the contractor shall be deemed to warrant that he has the authority to bind the contractor.

**3. SUBLETTING OF CONTRACT OR BILLS OR ANY BENEFIT ACCRUING THEREFROM**

- 3.1 The Contractor shall not sublet, transfer or assign the Contract or any part thereof or bills or any other benefits, accruing therefrom or under the contract without the prior written consent of the Purchaser (All Sub-contractors are required to be appraised and approved by the Purchaser before placement of orders by the Contractor/Supplier). However, such consent shall not be unreasonably withheld by the Purchaser, if such stores are not normally manufactured by the Contractor, such assignment or subletting shall not relieve the Contractor from any contractual obligation or responsibility under the Contract.
- 3.2 Any breach of this condition shall entitle the Purchaser to cancel the Contract or any part thereof and to purchase from other sources at the risk and cost of the Contractor and shall recover from the Contractor damages arising from such cancellations.
- 3.3 In case the Contractor sublets, transfers or assigns any part of the Contract with the prior written consent of the Purchaser, all payments to the Sub-Contractor shall be the responsibility of the Contractor and any requests from such sub-Contractor shall not be entertained by the Purchaser.

**4. SECURITY DEPOSIT**

- 4.1 On acceptance of tender, the Contractor shall at the option of the Purchaser and within the period specified by him, submit a Bank Guarantee from SBI or any one of the nationalized banks or reputed private banks, viz. AXIS Bank, ICICI Bank, IDBI Bank and HDFC Bank towards Security Deposit not exceeding 10% (ten percent) of the tendered value of the contract/purchase order valid till at least 2 months beyond the acceptance date of the material, as the Purchaser shall specify.
- 4.2 If the Contractor is called upon by the Purchaser to submit Security Deposit and the contractor fails to provide the same within the period specified such failure shall constitute a breach of the Contract and the Purchaser shall be entitled to make other arrangements for the repurchase of the stores contracted for at the risk and expenses of the Contractor in terms of clause 9.2.4 hereof and/or recover from the Contractor damages arising from such cancellation. No claim shall lie against the purchaser either in respect of interest if any due on Security Deposit or depreciation in value.
- 4.3 Offers wherein contractors declined to submit Security Deposit are liable to be rejected.

**5. DRAWINGS & SPECIFICATIONS**

- 5.1 The drawings and specifications are intended to be complementary and to provide for an comprise everything necessary for the completion of supply. Any material shown on the drawing even if not particularly described in specifications or vice versa is to be supplied by the Contractor as if it were both shown and specified.

- 5.2 Should any discrepancy be noted in the drawings and/or specifications and should any interpretation of the same be required, the matter shall be referred to the Purchaser for clarification which shall be binding upon the contractor. Otherwise, the contractor shall assume responsibility for the interpretation of the drawings and specifications including interpretation by his sub-contractors.
- 5.3 Should any difference or dispute arise with regard to the true intent and meaning of drawings or specification or should any portion of the same be obscure or capable of more than one interpretation, the same shall be decided by the Purchaser whose decision shall be final.
- 5.4 All lettering on the drawings is to be considered as part of the specification and contract. In all cases figured dimensions are to be followed rather than those indicated by scale. Large scale drawings will take precedence over small scale drawings.
- 5.5 The contractor's drawings shall, when approved by the Purchaser, be deemed to be included in the list of drawings which form part of the contract. The Contractor shall not proceed with fabrication until all drawings associated therewith have been duly approved by the Purchaser.
- 5.6 The Contractor shall be responsible for and shall pay for any alterations of the stores and shall indemnify the Purchaser for any consequential expenditure incurred by the Purchaser due to any discrepancies, errors, omissions in the drawings or other particulars supplied by him whether such drawings or specifications have been approved by the Purchaser or not, provided that such discrepancies, errors or omissions be not due to inaccurate information or specifications furnished to the contractor on behalf of the Purchaser.
- 5.7 **General Warranty**
- 5.7.1 The stores supplied by the contractor under the contract shall be of best quality and workmanship. The contractor shall supply the stores in accordance with the contract specifications unless any deviation has been expressly specified in the contract and any amendments agreed thereto.
- 5.7.2 The contractor's offer to supply stores in accordance with the tender specifications shall be deemed to be in admission on his part that he has fully acquainted himself with the details thereof and no claim shall lie against the Purchaser on the ground that the contractor did not examine or acquaint himself fully with the tender specifications.
- 5.8 **Contractor's Liability for Defective Stores**
- 5.8.1 For a period of twelve months after the stores have been accepted by Purchaser the Contractor shall be responsible for any defects that may be discovered therein notwithstanding that such defects could have been discovered at the time of inspection or any defects therein are found to have developed under proper use, arising from faulty materials, design or workmanship and the Contractor shall remedy all such defects as aforesaid at his own cost provided he is called upon within a period of 14 months from the date of acceptance thereof to do



so, by the Purchaser who shall state in writing in what respect the goods are faulty and further if in the opinion of the Purchaser the defects are of such a nature that it is necessary to replace or renew any defective stores, such replacement or renewal shall be made by the Contractor without any extra costs to the Purchaser, provided notice informing the Contractor of the defect is given by the Purchaser within the said period of 14 months. The decision of the Purchaser notwithstanding any prior approval or acceptance of the Inspector as to whether or not the stores delivered are defective or any defect has developed within the said period of twelve months or as to whether the nature of defects renewal or replacement shall be final conclusive and binding on the Contractor.

## **6. ALTERATIONS**

- 6.1 The Purchaser may, from time to time, make changes in the drawings specifications and issue additional instructions without altering the purchase order in any manner provided that no changes shall have been ordered which materially alter the character and scope of the supply under the contract.
- 6.2 It shall be lawful for the parties to the contract to alter by mutual consent at any time and from time to time the drawings and specifications and as from the dates specified by him stores to be supplied shall be in accordance with such altered drawings and specifications provided that if any such alterations involve increase or decrease in the cost of or in the period required for production, a revision of the contract price and/or the period prescribed for delivery shall be made by mutual agreement in respect of the stores to which the alteration applies. In all other respects, the contract shall remain unaltered.

## **7. SAMPLES**

- 7.1 Samples submitted for any reason shall be supplied without charge and freight paid without any obligation of the Purchaser as regards safe custody or safe-return thereof. All samples submitted must be clearly labelled with the Contractor's name and address and tender number. If the Contractor submits the sample with his tender the same shall not govern the standard of supply except when it has been specifically stated in the Purchase Order that it is accepted instead of any sealed pattern. Should certified samples be lent to the Contractor by the Purchaser, the Contractor is responsible for the return in perfect order of all certified samples with the labels intact.

## **8. PACKING**

- 8.1 The contractor shall be held responsible for the stores being sufficiently and properly packed for transport by rail, road, sea or air so as to ensure their being free from any loss or damages on arrival at their destination. The packing and marking of packages shall be done by and at the expenses of the Contractor. Each package shall contain a Packing

Note quoting Purchase Order number and date and showing its contents in detail.

- 8.2 Unless otherwise provided in the contract all containers (including packing cases, boxes, tins, drums and wrappings) in which the stores are supplied by the contractor shall be considered as property of the Purchaser and their cost as having been included in the contract price.

**9. DELIVERY:**

**9.1 TIME FOR AND DATE OF DELIVERY, THE ESSENCE OF THE CONTRACT:**

The time for and the date of delivery of the stores stipulated in the purchase order/contract shall be deemed to be of the essence of the contract and delivery must be completed not later than the date/dates stipulated.

**9.2 EXTENSION OF DELIVERY SCHEDULE**

- 9.2.1 If any delay in delivery shall have arisen from any cause such as strike, Lock-outs, fire, accidents, riot or the like which the purchaser may admit as reasonable ground for grant of extension of delivery schedule, the purchaser will allow such additional period for the purpose as he may consider necessary taking the circumstances into consideration.
- 9.2.2 If the contractor fails to deliver the stores or any instalment or part thereof within the period fixed for such delivery or such additional period allowed by the purchaser in accordance with foregoing paragraphs or any time before the expiry of such period repudiates the contract, the Purchaser may without prejudice to the rights of the purchaser.
- 9.2.3 Recover from the contractor as Liquidated Damages and not by way of penalty as detailed under clause No.222 given herein below for any stores which the contractor has failed to deliver within the period fixed for delivery in the contract or such additional period as mentioned in paragraph 9.2.1. during which the delivery of such stores, may be in arrears where delivery thereof is accepted after expiry of the aforesaid period. (For the purpose of computing the damages for delayed supplies under the clause, the cost of the entire plant/machinery/equipment/instrument will be taken into consideration if the plant/machinery/equipment/instrument cannot be put to the intended use for want of delayed portion of supply).
- 9.2.4 Purchase or authorise the purchase elsewhere without notice to the contractor, on account and at the risk of the contractor of the stores not so delivered or others of a similar description (where stores exactly complying with the contract specification are not in the opinion of the Purchaser, which opinion shall be final, readily procurable) without cancelling the contract in respect of the portion instrument not yet due of delivery, OR
- 9.2.5 Cancel the contract or portion thereof and if so desired purchase or authorise purchase of the stores not so delivered or others of a similar description (where stores exactly complying with the contract specification are not in the opinion of the Purchaser, which opinion shall be final, readily procurable) at the risk and cost of the contractor, if the contractor had defaulted in the performance of the original contract, the purchaser shall have the right to ignore his offer in response to risk purchase enquiry even though the lowest.

- 9.2.6 Where action is taken under sub-clause 9.2.4 or sub-clause 9.2.5 above the contractor shall be liable for any loss which the purchaser may sustain on that account provided that the repurchase, or if there is an agreement to repurchase then such agreement, is made within a reasonable period from the date of such failure, depending upon the nature / merit of the purchase and in case of repudiation of the contract before the expiry of the aforesaid period of delivery, shall not be entitled to any gain on such purchase and the manner and method of such purchase shall be in the entire discretion of the Purchaser. It shall not be necessary for the purchaser to serve a notice of such purchase on the contractor.

## **10. INSPECTION**

- 10.1 The contractor shall be responsible for and perform all inspection and testing required in accordance with the contract/purchase order and specifications included herewith.
- 10.2 The Purchaser may at his option depute his representative for Inspection of the stores to be supplied under the contract or authorize and nominate a Quality Surveillance Agency of his choice for the purpose hereinafter called, in either case, the inspection.
- 10.3 The contractor shall give notice of readiness for inspection to the Inspector (deputed under clause 10.2 above) so that the Inspector can be present at the requisite time. In such an event delivery shall not be effected until an authorization or shipping release is obtained from the Purchaser's Inspector.
- 10.4 The contractor shall allow reasonable facility and free access to his work/factory and records to the inspector for the purpose of inspection or for ascertaining the progress of delivery under the contract.

## **11. RECTIFICATION AND REPLACEMENT OF DEFECTIVE STORES**

- 11.1 If the inspector find that the contractor has executed any unsound or imperfect work, the inspector shall notify such defects to the contractor and the contractor on receiving the details of such defects or deficiency, shall at his own expenses, within seven days or otherwise within such time as may be mutually agreed upon as reasonably necessary, proceed to alter, reconstruct or remanufacture the stores to the requisite standard and specifications as called for by the tender specification.

## **12. INSPECTION AND REJECTION**

- 12.1 **Inspection and Rejection:** The stores shall be tendered by the Contractor for inspection at such places as may be specified by the Inspector, at the Contractor's own risk, expenses and costs and shall lie at such places of inspection at the risk of the Contractor and the stores will be subject to inspection and test as may be considered necessary by the inspector and his decision as regards rejection of goods shall be final and binding on the Contractor. If any goods are rejected as aforesaid, then without prejudice to the foregoing provision, the Purchaser shall be at liberty to
- 12.1.1 Allow the Contractor to re submit without prejudice to the Purchaser's right to claim and recover Liquidated damages as provided in clause 9.2.3 hereof, stores in replacement of those rejected within a time specified by the Purchaser (which time shall be essence of the contract), the contractor bearing the

- cost of freight for such replacement without being entitled to any extra payment, or
- 12.1.2 Buy the quantity of stores rejected or others of a similar nature elsewhere at the risk and cost of the Contractor in accordance with the provisions contained in second paragraph of clause 9.2.4 thereof without effecting the Contractor's liability as regards the supply of any further consignments due under the Contract, or
- 12.1.3 Terminate the Contract and recover from the Contractor the loss Purchaser thereby incurred
- 12.2 **Removal of rejection:** Any stores submitted for inspection and rejected by the Inspector must be removed by the Contractor within fourteen days from the date of receipt of intimation of rejection, provided that in the case of dangerous infected or perishable stores, the Inspector (whose decision shall be final) shall notify the Contractor to remove such stores within 48 hours of receipt of intimation of rejection and it shall be the duty of the Contractor to remove them accordingly. Such rejected stores shall lie at the Contractor's risk from the time of such rejection and if not removed within the aforementioned time, the Purchaser shall have the right either to return the rejected stores to the Contractor at the Contractor's risk by such mode of transport as Purchaser may select or to dispose off or segregate such stores as he thinks fit at the Contractor's risk and on his accounts and to appropriate such portion of the proceeds as may be necessary to cover any loss or expenses incurred by the Purchaser in connection with the said sale. Freight to destination of stores rejected after examination at destination shall be recoverable from the Contractor at the Tariff Rate.
- 12.3 **Test Certificate and Guarantees:** Test Certificate Guarantees, if required by the Inspector shall be obtained and furnished by the Contractor free of costs.

### **13. RECOVERY OF SUMS DUE**

- 13.1 Whenever any claim for payment of, whether liquidated or not, moneys arises out of or under this contract against the Contractor the Purchaser shall be entitled to recover sum by appropriating, in part or whole, by encashing the Bank Guarantee submitted towards Security deposit by the Contractor, if a Security Deposit is taken against the Contract. In the event of the security being insufficient or no Security Deposit has been taken from the Contractor then the balance or the total sum or which at any time hereafter may become due to the Contractor under this or any other contract with the Purchaser, should this sum be not sufficient to cover the full amount recoverable, the Contractor shall pay to the Purchaser on demand the remaining balance due. Similarly, if the Purchaser has or makes any claim, 'whether liquidated or not against the Contractor under any other contract with the Purchaser the payment of all moneys payable under the contract to the contractor including the security deposit shall be withheld till such claims of the Purchaser are finally adjudicated upon and paid by the Contractor.
- 13.2 All demurrage, wharfage and allied expenses incurred by the Purchaser, if any, due to delayed clearance of Stores in view of non receipt, incomplete or delayed receipt of documents by the Purchaser, shall be recovered from the payment due to the Contractor.

**14. BAR/PERT CHART**

- 14.1 The contractor at the discretion of the Purchaser shall submit the BAR/PERT chart indicating various activities from the date of purchase order to handing over of the stores.

**15. PERFORMANCE BANK GUARANTEE**

- 15.1 In the event of acceptance of the offer in respect of plant, machinery, equipment, instrument, etc. the tenderer will be required to submit a performance bank guarantee for 10% of the total value of the stores inclusive of all statutory levies and other charges admitted in the contract, from SBI/any nationalized bank or private sector banks, namely, ICICI Bank, IDBI Bank, HDFC Bank and AXIS Bank, on a non-judicial stamp paper of appropriate value valid till 2 months beyond the expiry date of warranty period as per the Purchaser's format towards satisfactory performance of the plant, machinery, equipment, instrument, etc. during the warranty period. In case of bids in currency other than INR performance bank guarantee shall be furnished from any bank of international repute.
- 15.2 In case of non-submission of performance bank guarantee by the Contractor, an amount equivalent to 10% of the total value of the stores and other charges admitted in the contract will be retained by the purchaser till the expiry of the warranty period of the stores.
- 15.3 Offers of the tenders who are not agreeable to furnish performance bank guarantee or retaining of an equivalent amount by the purchaser as per clause No.15.1 and 15.2 above, are likely to be rejected.

**16. PERMIT AND LICENCES**

- 16.1 The contractor shall secure and pay all licenses and permit at his end which he may be required to comply with all laws ordinances and regulations of the public authorities in connection with the performance of his obligations under the contract. The contractor shall be responsible for all damages and shall indemnify and save the purchaser harmless from against all claims for damages and liability which may arise out of the failure of the contractors to secure and pay for any such licenses and permits or to comply fully which any and all applicable laws ordinances and regulations.

**17. PATENTS & PATENT RIGHTS INDEMNIFICATION**

- 17.1 The Contractor shall indemnify and keep indemnified the Purchaser from and against any and all claims, actions, costs, charges and expenses arising from or for infringement of patent rights, copy right or other protected rights, of any design plans, diagrams, drawings in respect of the stores supplied by the contractors or any of the manufacturing methods or process adopted by contractor for the stores supplied under the contract.
- 17.2 In the event of any claim being made or action being taken against the purchaser in respect of the matter referred to clause 17.1 above, the contractor shall promptly be notified thereof and he shall at his own expense, conduct all negotiations for the settlement of the same and any litigation that may arise therefrom.
- 17.3 In the event of any designs, drawing, plans or diagrams or any manufacturing methods or process furnished by the contractor constituting infringement of patent or any other protected rights and use thereof is restrained, the contractor shall procure for Purchaser, at

no cost to the latter, the rights to continue using the same or to the extent it is possible to replace the same so as to avoid such infringement and subject to approval by the Purchaser or modify them so that they become non-infringing, but such modifications shall otherwise be to the entire satisfaction of the Purchaser.

17.4 The provision of the clause remains effective and binding upon the Contractor even after the completion, expiration or termination of the contract.

## **18. LAW GOVERNING THE CONTRACT**

18.1 This Contract shall be governed by the laws of India for the time being in force. The marking of all stores supplied must comply with the requirements of India Acts relating to Merchandise Marks and all the rules made under such Acts.

## **19. JURISDICTION**

19.1 The Courts within the local limits (i.e. Gandhinagar) of whose jurisdiction the place from which the purchase order is issued is situation only shall, subject to Arbitration Clause, have jurisdiction to deal with and decide any matter out of this Purchase Order/Contract.

## **20. SETTLEMENT OF DISPUTES**

20.1 The Purchaser and the Contractor shall make every effort to resolve amicably by direct informal negotiation any disagreement or dispute arising between them under or in connection with the Contract.

20.2 If the parties have failed to resolve their dispute or difference by such mutual consultation, then either the Purchaser or the Supplier may give notice to the other party of its intention to commence arbitration, as hereinafter provided, as to the matter in dispute, and no arbitration in respect of this matter may be commenced unless such notice is given. Any dispute or difference in respect of which a notice of intention to commence arbitration has been given in accordance with this Clause shall be finally settled by arbitration. Arbitration may be commenced prior to or after delivery of the Goods under the Contract.

## **21. ARBITRATION**

21.1.1 In the event of any dispute or difference arising out or of in connection with any of the terms and conditions of the Purchase Order/Contract, the matter shall be referred to the Director, IPR for settlement. In case the parties to the Purchase Order are not in a position to settle the dispute mutually, the matter shall be referred to a Sole Arbitrator to be appointed in accordance with the Arbitration & Reconciliation Act, 1996 & Arbitration and Conciliation (Amendment) Act, 2015 as amended time to time.

## **22. LIQUIDATED DAMAGES**

22.1 As per Standard Terms & conditions, the Purchaser reserves the right to levy the Liquidated Damages, for delay in supply beyond the contractual delivery date at the rate of half percent (0.5 percent) of the total Contract price (Basic price) for each calendar week of delay. The total liquidated damages shall not exceed five percent (5%) of the contract price (Basic price). Stores/Goods will be deemed to have been delivered only when all its component parts are also delivered. If certain

components are not delivered in time, the Stores/Goods will be considered as delayed until such time as the missing parts are delivered.

- 22.2 Where the Contract entered into is a composite one with supply cum erection and installation/commissioning activities and the completion of erection and installation/commissioning is delayed irrespective of the fact that whether supply of material has been made within the original delivery period, the contract is to be considered as a whole and Liquidated Damages will be recovered on the total contract value.

**23. EXERCISING THE RIGHTS AND POWERS OF THE PURCHASER**

- 23.1 All the rights, discretions and powers of the Purchase under the contract shall be exercisable by and all notices on behalf of the Purchaser shall be given by the Purchase Officer and any reference to the opinion of the Purchaser in the terms and conditions contained in these General Conditions of all Contracts shall mean and be construed as reference to the opinion of any of the persons mentioned in this clause.

**24. TRAINING**

- 24.1 The successful tenderer shall, if required by the Purchaser, provide facilities for the practical training of Purchaser's engineering or technical personnel for their active association on the manufacturing process throughout the manufacturing period of the Contract/stores, number of such personnel to be mutually agreed upon. If demanded by the Purchaser, such training shall be conducted at Purchaser's site by the Contractor free of charge. The duration of training shall be mutually decided upon by the Purchaser and the Contractor.

**25. RISK PURCHASE**

- 25.1 In the event supplier fails to fulfill the contractual obligations as per the terms and conditions of the Contract, the Purchaser has an option of completing the Contract at the risk and expenses of the Contractor. While initiating risk purchase at the risk and expenses of the supplier, the Purchaser must satisfy himself that the supplier has failed to deliver and he has been given all the opportunities as per the Contract to execute the Contract and also adequate and proper notice. Wherever risk purchase is resorted to, the supplier is liable to pay the additional amount spent by the government, if any as compared to contracted amount. All the factors including the method of recovering such amount should also be considered while taking a decision to invoke the risk purchase.

**26. LIEN IN RESPECT OF CLAIMS IN OTHER CONTRACTS**

- 26.1 Any sum of money due and payable to the Contractor under any contract may be withheld or retained by way of lien by the purchaser or any other person or persons contracting through the Director, IPR against any claim of the Purchaser or such other person or persons in respect of payment of a sum of money arising out of or under any other contract made by the contractor with the Purchaser or with other such person or persons.
- 26.2 It is an agreed term of the contract that the sum of money so withheld or retained under this clause by the Purchaser will be kept withheld or retained as such by purchaser till this claim arising out of in the same

contract or any other contract is either mutually settled or determined by the arbitrator, and that the contractor shall have no claim for interest or damages whatsoever on this account or on any other ground in respect of any sum of money withheld or retained under this clause and duly notified as such to the contractor.



## **SPECIAL CONDITIONS OF CONTRACT GOVERNING SUPPLIES OF PLANT AND MACHINERY**

In addition to the General Conditions of Contract hereinbefore set out the following special conditions shall apply to contracts for the supply of Plant and Machinery and manufactured equipment. These Special Conditions where they differ from the General Conditions shall over-ride the later.

### **27. DEFINITION OF PLANT**

27.1 The word "PLANT" wherever, appears in these "Special Conditions of Contract governing supplies of Plants and Machinery" shall mean all machinery, plants, equipment or parts thereof or what the Contractor agrees to supply under contract as specified in the Purchase Order.

### **28. MISTAKES IN DRAWING**

28.1 The Contractor shall be responsible for and shall pay for an alterations of the works due to any discrepancies, errors or omissions in the drawings or other particulars supplied by him whether such drawings or particulars have been approved by the Purchaser or not.

### **29. RESPONSIBILITY FOR COMPLETENESS**

29.1 All fittings or accessories which may not be specifically mentioned in the specification but for which are usual or necessary, are to be provided by the Contractor without extra charge and the plant must be complete in all respects.

### **30. REJECTION OF DEFECTIVE PLANT**

30.1 If the completed plant or any portion thereof before it is finally accepted is found to be defective or fails to fulfill the requirements of the contract, the Purchaser shall give the Contractor notice setting forth with the details of such defects or failure and the contractor shall forthwith rectify the defective plant or alter the same to make comply with the requirement of the contract. Should the contractors fail to do so within a reasonable time the Purchaser may reject and replace at the cost of the Contractor, the whole or any portion of the Plant as the case may be, which is defective or fails to fulfill the requirement of the contract. Such replacement shall be carried out by the Purchaser within a reasonable time and at reasonable price and where reasonably possible to the same specifications and under competitive conditions. The Contractor shall be liable to pay to the Purchaser the extra cost, if any, of such replacement delivered and or erected as provided for in the contract such extra cost being the difference between the price paid by the Purchaser under the provisions above mentioned for such replacement and the contract price for them. Contractor shall refund to Purchaser any sum paid by the Purchaser to the Contractor in respect of such defective plant.

### **31. INSPECTION AND FINAL TESTS**

31.1 All tests necessary to ensure that the plant complies with the particulars and guarantees shall be carried out at such place or places as may be determined by the inspector. Should, however, it be necessary for the final tests as to performance or guarantees to be held over until the Plant is erected at site they shall be carried out within

one month of completion of erection.

**32. TRANSPORT AND RESPONSIBILITY FOR BREAKAGES EN-ROUTE**

- 32.1 Unless otherwise specified the Purchaser will take delivery of the plant from the place named in the purchase order but the contractor will be responsible for any damage which may be caused to the Plant during transit to the site of erection thereof.

**33. ERECTION AND COMMISSIONING**

- 33.1 In all cases where contracts provide for supervision of erection and commissioning or for test at the Purchaser's premises the Purchaser except where otherwise specified, shall provide free of charge, such labour, materials, fuels, stores, apparatus and instruments as may be required from time to time and as may reasonably be demanded by the contractor to carryout efficiently such supervision of erection and commissioning and for the requisite test. In case of contracts requiring electricity for the completion of erection, commissioning and testing at site, such electricity shall be supplied free to the contractor.
- 33.2 Action by the Purchaser under the clause shall not relieve the contractor of his warranty obligations under the contract.

**34. WARRANTY**

- 34.1 The contractor warrants that stores to be supplied under the contract shall be free from all defects and faults in materials, workmanship and manufacture and shall be of the highest grade and consistent with the established and generally accepted standards for stores of the types under the contract in full conformity with the specifications, drawings or samples, if any and shall if operable, operate properly. This warranty shall expire (except in respect of complaints notified to the contractor prior to such date) twelve months after the date of receipt of the last lot of stores under the contract at the ultimate destination stipulated in the contract.
- 34.2 For a period of twelve calendar months after the plant/machinery/equipment/instruments has been put into operation (or a suitable mutually agreed longer period to be reckoned from the date of last major shipment depending upon the nature of the plant/machinery/equipment/instrument) the Contractor shall be responsible for any defects that may develop under conditions provided for the contract and under proper use, arising from the faulty materials, design or workmanship in the plant or from faulty erection of the plant by the Contractor, but otherwise and shall rectify such defects at his own cost when called upon to do so by the Purchaser who shall state in writing such defects.
- 34.3 If it becomes necessary for the Contractor to replace or renew any defective portions of the plant for purpose of rectification under this clause, the provisions of this clause shall apply to the portions of the plant so replaced or renewed under the expiration of six months from the date of such replacement or renewal or until the end of the above mentioned period of twelve months whichever may be the later. If any defects not rectified within reasonable time, the purchaser may proceed to get the work done at contractor's risk and expenses but without prejudice to any other rights which the Purchaser may have against the Contractor in respect of such defects as provided in clause 9.2.4 or 9.2.5.

- 34.4 All inspections adjustments, replacements or renewals carried out Contractor during the warranty period shall be subject to the same conditions as in the contract.
- 34.5 Contractor shall, spare parts of equipment before going out of production, give adequate advance notice to the purchaser so that the latter may order requirement of spares in one lot if so desires.
- 34.6 The contractor shall further guarantee that if spare parts go out of production, will make available blue prints, drawings of spare parts and specifications of material at no cost to the Purchaser, if and when required in connection with the equipment to enable Purchaser to fabricate or procure spare parts from other sources.
- 34.7 The provision of this clause shall remain effective and binding upon the Contractor even after the completion or expiration of the contract and till the plant/machinery/equipment supplied under the contract is in use by the Purchaser.

### **35. MODE OF PAYMENT**

- 35.1 Unless otherwise agreed to in writing between the Purchaser and the Contractor, payment for the delivery of the material will be made as follows.
- Within 30 days from the date of final acceptance and on receipt of Performance Bank guarantee for 10% of the contract value amount from SBI/nationalized banks or any one of the scheduled banks mentioned in the bracket (Axis Bank, HDFC Bank, ICICI Bank and IDBI Bank) valid through out the guarantee period mentioned in the contract/purchase order.**
- 35.1.1 In case any of the vendors seek advance or progressive payment prior to delivery of the material, such requests can be considered only in exceptional cases of large value items, in which case the vendor will be required to furnish a bank guarantee for an equivalent amount of the advance/progressive payment sought for, valid till the execution of the contract. The bank guarantee shall be got executed as per the Purchaser's format from the State Bank of India (SBI)/nationalized banks or any one of the scheduled banks mentioned in the bracket (Axis Bank, HDFC Bank, ICICI Bank and IDBI Bank).
- 35.1.2 Besides, the offers of the vendors seeking advance/progressive payment will be evaluated by loading 12% interest charges per annum on the amount of advance desired up to the delivery period quoted.
- 35.1.3 In case any of the vendors seek pro-rata payment for the stores to be supplied they should clearly mention in their offer the maximum number of installments of supply. However, such installment delivery and pro-rata payment will be considered only in respect of contract involving large value and sizeable quantity of the item and the maximum number of installments shall be normally restricted to four. Acceptance or otherwise of this condition is reserved by the purchaser.
- 35.1.4 **Bank Charges:** All bank charges to be borne by the Contractor/Supplier.
- 35.1.5 No correspondence will be entertained within 30 days from the date of receipt of material and bills, whichever is later.
- 35.1.6 **Interest for delay in supply beyond the contractual delivery date:** Wherever advance payments are sought for by the contractor and

admitted in the contract, against Bank Guarantee for equivalent amount, in the event of any delay in supply beyond the contractual delivery date for reasons attributable to the contractor, interest charges @ 12% shall be levied for the period beyond the contractual delivery date, on the amount of balance advance payment to be adjusted.

**36. DELAY IN ERECTION**

36.1 Wherever erection of a plant or machinery is the responsibility of the Contractor as a term of the contract and in case the Contractor fails to carry out the erection as and when called upon as to do within the period specified by the Purchaser, the Purchaser shall have right to get the erection done through any source of his choice. In such an event, the contractor shall be liable to bear any additional expenditure that the Purchaser may incur towards erection. The Contractor shall, however, not be entitled to any gain due to such an action by the Purchaser.

**SECTION 'C'**

**TECHNICAL SPECIFICATIONS  
OF  
STORES AND DRAWINGS**

***Please refer tender document***

## **SECTION 'D'**

### **FORMAT FOR SUBMISSION OF PART-II (PRICE)**

***Please refer tender document***



## DEFERRED TERMS

TENDER FORM  
प्लाज्मा अनुसंधान संस्थान  
(भारत सरकार के परमाणु ऊर्जा विभाग का सहायता प्राप्त संस्थान)  
इंदीरा ब्रिज के पास, भाट, गांधीनगर - 382428, भारत  
दूरभाष: 079-23962020/23962021, फ़ैक्स: 079-23962277

Following terms are **replaced** in our Form for Tender No. **IPR/TN/PUR/TPT/ET/21-22/036** dated **30-12-2021**.

- 1) Sr.No.3 (Sub-clause No. 3.1) of Section-A under heading **“Earnest Money Deposit (EMD)”** of Form No.IPR-LP-ET-02.V5 (Terms and Conditions) is replaced with the following:

**Earnest Money Deposit (EMD) is not applicable as per Office Memorandum No. F.9/4/2020-PPD dated 12/11/2020** issued by Ministry of Finance, Department of Expenditure, Procurement Policy Division, Government of India. In place of submission of EMD, vendor may upload a signed **“Bid Security Declaration”** as per the attached **Annexure-V** accepting that if they withdraw or modify their bids during the period of validity etc., they will be suspended for future requirements of IPR.

- 2) Sr. No. 15.3 (Section-A) under heading **“TENDERING CONDITIONS FOR BIDS”** of Form No.IPR-LP-ET-02.V5 (Terms and Conditions) is replaced with the following:  
Quotation/ offer should be on FOR, IPR Gandhinagar basis only. Quotation/offer received in any other terms/ conditions shall not be considered.
- 3) Sr. No. 15.6 (Section-A) under heading **“TENDERING CONDITIONS FOR BIDS”** of Form No.IPR-LP-ET-02.V5 (Terms and Conditions) is deleted
- 4) Sr.No.18 (Section-A) under heading **“Statutory Levies such as Customs Duty, Goods and Service Tax”** of Form No.IPR-LP-ET-02.V5 (Terms and Conditions) is replaced with the following:

**Clause Nos.18.1, 18.2, 18.3, 18.5.2 and its sub-clauses deleted from Form No: IPR-LP-ET-02.V5.**

- 5) Sr. No. 46 (Section-A) under heading **“Price/Purchase Preference”** of Form No.IPR-LP-ET-02.V5 (Terms and Conditions) is replaced with the following:  
**Purchase/Price preference:** Purchase/Price preference benefits under MSME/NSIC including benefits under PPP-Make India policy will be provided to the industries as per the policies of the Government

## DEFERRED TERMS

of India in force at the time of evaluation of the offers provided their offer is in compliance with the terms and conditions of the tender.

- 6) Sr. No. 4.1 (Section-B) under heading **“Security Deposit”** of “General Conditions of Contract of Form No.IPR-LP-ET-02.V5 (Terms and Conditions) is replaced with the following:

On acceptance of tender, the Contractor shall at the option of the Purchaser and within the period specified by him, submit a Bank Guarantee from State Bank of India or any Indian Nationalized/ Scheduled Banks as appearing in the second schedule of Reserve Bank of India (other than co-operative and Grameen Banks) on a non-judicial stamp paper of appropriate value towards Security Deposit not exceeding **3% (three percent)** of the tendered value of the contract/purchase order valid till at least 2 months beyond the acceptance date of the material, as the Purchaser shall specify. Bank Guarantees submitted other than from banks approved by IPR will not be accepted.

- 7) (a) Sr. No. 15.1 (Section-B) under heading **“Performance Bank Guarantee”** of “General Conditions of Contract of Form No.IPR-LP-ET-02.V5 (Terms and Conditions) is replaced with the following:

In the event of acceptance of the tender, the Contractor will be required to submit a performance bank guarantee for **3% of the total value of the stores inclusive of all statutory levies and other charges** admitted in the contract, from State Bank of India or any Indian Nationalized/ Scheduled Banks as appearing in the second schedule of Reserve Bank of India (other than co-operative and Grameen Banks), on a non-judicial stamp paper of appropriate value valid till 2 months beyond the expiry date of warranty period as per the Purchaser’s format towards satisfactory performance of the Stores during the warranty period. Bank Guarantees submitted other than from banks approved by IPR will not be accepted.

- 8) Sr. No. 22.1 (Section-B) under heading **Liquidated Damages** of “General Conditions of Contract” of Form No.IPR-LP-ET-02.V5 (Terms and Conditions) is replaced with the following:

**Liquidated Damages:** As per Standard Terms & conditions, the Purchaser reserves the right to levy the Liquidated Damages, for delay in **completion period beyond the contractual completion date at the rate of half percent (0.5 percent) of the total Contract price (Basic price of item sr.no. 1.01 to 1.04)** for each calendar week of delay. **GST @ 18% will be applicable on LD charges.** The total liquidated damages shall not exceed five percent (5%) of the contract price (Basic price). Stores/Goods will be deemed to have been delivered only when all its component parts are also delivered. If certain components are not delivered in time, the Stores/Goods will be

## DEFERRED TERMS

considered as delayed until such time as the missing parts are delivered.

- 9) Sr. No. 34.2 (Section-B) under heading “Warranty of “General Conditions of Contract” of Form No.IPR-LP-ET-02.V5 (Terms and Conditions) is replaced with the following:

**Warranty:**

12 months from the date of approval of Site Acceptance Test (SAT) against all sorts of manufacturing defects, faulty materials and poor workmanship.

- 10) Sr. No. 35 (Section-B) under heading Mode of Payment of “General Conditions of Contract” of Form No.IPR-LP-ET-02.V5 (Terms and Conditions) is replaced with the following:

**Payment:** Unless otherwise agreed to in writing between the Purchaser and the Contractor, payment for the delivery of the tendered items, will be made as follows.

- a) 10% of basic price of Item No. 1 to 5 of Price-Schedule will be paid as an **advance** against approval of design and manufacturing drawings of bellows EJ-1, 2 & 3, and on submission of Bank Guarantee for an equivalent amount from State Bank of India or any Indian Nationalized /Scheduled Banks as appearing in the second schedule of Reserve Bank of India (other than Co-Operating and Grameen Banks) on a non-judicial stamp paper of appropriate value valid till delivery of the system and on receipt of Proforma Invoice in triplicate.
- b) 10% of basic price of Item No. 1 to 5 of Price-Schedule will be paid as an **advance** against submission of documentary proof of procurement of major raw materials along with test reports & its acceptance of by IPR and Approval of Manufacturing Readiness Review (MRR) documents mentioned in Section-C of the tender document, and on submission of Bank Guarantee for an equivalent amount from State Bank of India or any Indian Nationalized / Scheduled Banks as appearing in the second schedule of Reserve Bank of India (other than Co-Operating and Grameen Banks) on a non-judicial stamp paper of appropriate value valid till delivery of the system and on receipt of Proforma Invoice in triplicate.
- c) 60% of basic price of Item Sr. No. 1, 2 and 3 of Price-Schedule +100% of all other charges pertaining to Item sr.no.1, 2 and 3 of Price-Schedule will be paid after acceptance of FAT and delivery of bellows EJ-1 & EJ-2 (Deliverable – A, B & C) at IPR, Gandhinagar Site, its physical verification by representative of IPR and on receipt of Invoice in triplicate.

## **DEFERRED TERMS**

- d) 60% of basic price of Item Sr. No. 4 and 5 of Price-Schedule +100% of all other charges pertaining to Item sr.no.4 and 5 of Price-Schedule will be paid after acceptance of FAT and delivery of bellows EJ-3 (Deliverable – D & E) at IPR, Gandhinagar Site, its physical verification by representative of IPR and on receipt of Invoice in triplicate.
- e) Balance 20% of basic price of Item Sr.No. 1 to 5 of Price-Schedule and 100% of Item Sr. No. 6 of Price-Schedule will be paid within 30 days after testing and final acceptance of the system at IPR Site, on receipt of Performance Bank Guarantee for 3% of the order value inclusive of all statutory levies and other charges from State Bank of India or any Indian Nationalized/Scheduled Banks as appearing in the second schedule of Reserve Bank of India (other than co-operative and Grameen Banks), on a non-judicial stamp paper of appropriate value valid throughout the warranty period (**Plus additional 2 months grace period**) and on receipt of final invoice.

### **IMPORTANT NOTE:**

- (a) Installation, testing & Commissioning charges (if applicable) should be inclusive of loading, unloading at IPR site, shifting, handling with accessories)
- (b) Detailed specifications and scope of work are as per Section-C of tender document.
- (c) If the rate cells are left blank, it will be treated as "0" (ZERO)
- (d) Custom Duty Exemption certificate will not be issued to any bidder under any circumstances.
- (e) Prices as per bid format are only acceptable
- (f) GST (IGST, CGST, SGST or any form) should not be included in the basic cost (Unit Rate Column) for either goods or services.
- (g) Evaluated total cost on the basis of bid prices will be calculated by Purchaser after bid opening.
- (h) HSN/SAC Code: For indigenous goods/services, to be filled by the bidder

Following **ADDITIONAL CLAUSES** are **added to** our Form No. IPR-LP-ET 02.V5 for Tender No. **IPR/TN/PUR/TPT/ET/21-22/036** dated **30-12-2021**.

#### **1. MAKE IN INDIA**

- i. As defined under the Public Procurement (Preference to Make in India), order 2017, Revised order dated: 16/09/2020 or as being revised from time to time, in procurement of goods or services in

## **DEFERRED TERMS**

respect of which the Nodal Ministry/Department has communicated, that there is sufficient local capacity and local competition, only “Class-I local supplier”, as defined under the said order, shall be eligible to bid irrespective of purchase value.

- ii. Only “Class-I local supplier” and “Class-II local supplier”, as defined under the above said order, shall be eligible to bid in procurements under taken by this Institute, except where the mode of procurement is by issue of Global Tender Enquiry. The bidding supplier shall indicate the percentage of local content for the item being offered in their bid.
- iii. Where the procurement is by issue of Global Tender enquiry, Non local suppliers, shall also be eligible to bid along with “Class-I local suppliers and Class-II local suppliers”. Suppliers/bidders offering imported products will fall under the category of Non-local suppliers.
- iv. Subject to the provisions of the above said order, and to any specific instructions issued by the Nodal Ministry or in pursuance of the said order, purchase preference shall be given to “Class-I local Suppliers” in procurements under taken by this Institute, in the manner specified there in the order.
- v. The bidders along with their bid/tender shall be required to provide a self-declaration certificate of the local content (where the procurement value is Rs.10 Crore or less) for the item offered and their status as Class-I/Class-II/Non-Local supplier and their eligibility to participate in the tender. In cases of procurement for a value in excess of Rs.10 crores, the “Class-I local supplier”/“Class-II local supplier” shall be required to provide a certificate from the statutory auditor or cost auditor of the company (in the case of companies) or from a practicing cost accountant or practicing chartered accountant (in respect of Contractors other than companies) giving the percentage of local content.
- vi. Self-declaration certificate should quantify the percentage of local content of the offered product only. It should also indicate the location. However, claiming the services such as transportation, insurance, installation & commissioning, training and after sale service support like AMC/CMC etc., shall not be considered as local content as per OM N.P-45021/102/2019-BE-II-Part(1)(E- 50310) dated:4/03/2021 issued by Ministry of Commerce and Industry, DPIIT.
- vii. False declarations/violation of this order terms shall be deemed to be breach of code of integrity resulting in debarment of the firm for a period up to 2 years. Under such circumstances, the supplier shall not be considered for any preferences as proposed in the order.
- viii. Wherever the bids are received without accompanying the above said requisite certificate such offers shall be treated as

## **DEFERRED TERMS**

incomplete and not considered.

- ix. Bidders/contractor are divided into three categories based on Local Content (The total value of the item procured (excluding net domestic indirect taxes) minus the value of imported content in the item (including all customs duties) as a proportion of the total value, in percent):
1. Class-I local supplier is with local content equal to or more than as prescribed by the Nodal Ministry/ NIT, if prescribed, for the item being procured or 50% whichever is higher.
  2. Class-II Local supplier is with local content equal to or more than as prescribed by the Nodal Ministry/NIT, if prescribed, for the item being procured or 20% whichever is higher, but less than that applicable for class-I local supplier.
  3. Non-local supplier is with local content less than that applicable to class-II local supplier, as stated above.

*Note: Where the estimated value of the procurement is less than Rs.5 Lakhs (or as being amended by the competent authority from time to time) is exempted from the provisions of the above Make in India policy as stated therein the order.*

Self-certification under preference to “Make in India” order as per **Annexure-I** should be uploaded on e-tender portal along with other documents.

### **2. ELIGIBILITY OF BIDDERS FROM SPECIFIED COUNTRIES:**

- i. Orders issued by the Government of India restricting procurement from bidders of certain countries which shares a land border with India shall apply to this procurement.
- ii. Any bidder from a country which shares a land border with India ( <https://mea.gov.in/india-and-neighbours.htm> ), excluding countries as listed in the website of Ministry of External Affairs ( <https://meadashbaord.gov.in/indicators/92> ), to which the Government of India has extended lines of credit or in which the Government of India is engaged in development projects – hereinafter called “Restricted countries”) shall be eligible to bid in this tender only if the bidder is registered ( <https://dipp.gov.in/sites/default/files/Revised-Application-Format-for-Registration-of-Bidders-15Oct2020.pdf> ) with the Registration committee constituted by the Department for promotion of Industry and Internal Trade(DPIIT) . The bidders shall enclose valid registration certificate along with their offer. Wherever the bids are received without accompanying the above said requisite certificate such offers shall be treated as incomplete and not considered.

## **DEFERRED TERMS**

Self-certification under **ELIGIBILITY DECLARATIONS FROM SPECIFIED COUNTRIES** order as per **Annexure-II** should be uploaded on e-tender portal along with other documents.

- 3. UNDERTAKING:** Acceptance of tender condition as per **Annexure-III** should be uploaded on e-tender portal along with other documents.

### **4. CODE OF INTEGRITY**

No official of a procuring entity or bidder or contractor shall act in contravention of the codes which include

- (i) Prohibition of
  - (a) making offer, solicitation or acceptance of bribe, reward or gift or any material benefit, either directly or indirectly, in exchange for an unfair advantage in the procurement process or to otherwise influence the procurement process.
  - (b) any omission, or misrepresentation that may mislead or attempt to mislead so that financial or other benefit may be obtained or an obligation avoided.
  - (c) any collusion, bid rigging or anticompetitive behavior that may impair the transparency, fairness and the progress of the procurement process.
  - (d) improper use of information provided by the procuring entity to the bidder with an intent to gain unfair advantage in the procurement process or for personal gain.
  - (e) any financial or business transactions between the bidder and any official of the procuring entity related to tender or execution process of contract; which can affect the decision of the procuring entity directly or indirectly any coercion or any threat to impair or harm, directly or indirectly, any party or its property to influence the procurement process.
  - (f) obstruction of any investigation or auditing of a procurement process.
  - (g) making false declaration or providing false information for participation in a tender process or to secure a contract;
- (ii) Disclosure of conflict of interest.
- (iii) Disclosure by the bidder of any previous transgressions made in respect of the provisions of sub-clause (i) with any entity in any country during the last three years or of being debarred by any other procuring entity.

## **DEFERRED TERMS**

- (iv) Institute for Plasma Research, after giving a reasonable opportunity of being heard, comes to the conclusion that a bidder or prospective bidder, as the case may be, has contravened the code of integrity, may take appropriate measures as deemed fit, including rejecting his bid and forfeiting EMD and/or debarring him from participating in future bidding.

**5. Commercial Bid (Unpriced) :** Vendor/ Bidder should upload the duly filled (signed and stamped) copy of commercial bid( unpriced) as per [Annexure-IV](#)

**6. TDS as per CGST Act:** As per the provisions mentioned under Section No. 51 of the CGST Act 2017, TDS @ 2% (IGST 2% or CGST 1% and SGST 1%) will be deducted while making payment to the suppliers where total value of the purchase order/contracts/work orders exceeds Rs.2.5 Lakhs. Necessary TDS Certificate will be issued to the supplier after TDS deduction.

### **IMPORTANT NOTE:**

**[1] QUOTATIONS ARE INVITED IN INDIAN CURRENCY ONLY.**

**[2] QUOTATIONS RECEIVED OTHER THAN “INR” QUOTE SHALL SUMMARILY BE REJECTED.**



(To be printed in letter head)

---

**ANNEXURE-I**

**Self-Certification under preference to Make in India order Certificate**

In line with Government Public Procurement Order No. P-45021/2/2017-PP (BE-II) dated 04.06.2020 and its amendments, we hereby certify that we M/s. \_\_\_\_\_ are local supplier meeting the requirement of minimum local content i.e., \_\_\_\_\_% excluding transportation, insurance, installation, commissioning, testing, training and after sales service support like AMC/CMC etc. as defined in above orders for the material against **IPR Enquiry/Tender No. IPR/TN/PUR/TPT/ET/21-22/036 DATED 30-12-2021** Details of location at which local value addition will be made as follows:  
\_\_\_\_\_.

We also understand, false declarations will be in breach of the code of integrity under rule 175(1) (i) (h) of the General Financial Rules for which a bidder or its successors can be debarred for up to two years as per Rule 151(iii) of the General Financial Rules along with such other actions as may be permissible under law.

Thanking You,

---

**Signature with date:**

**Name:**

**Designation:**

**Official Seal**

## ANNEXURE-II

### Annexure to Bid Form: Eligibility Declaration

(To be submitted as part of tender/Technical Bid)  
(On company letter head)  
(Along with supporting documents, if any)

Tender No: **IPR/TN/PUR/TPT/ET/21-22/036 dated 30-12-2021**

Tender Title: **Design, Manufacturing, Inspection, Testing, FAT, Supply and SAT of Double walled bellows at Institute for Plasma Research, Gandhinagar as per the detailed specifications mentioned in the tender documents.**

Bidder's Name: \_\_\_\_\_

(Address and contact details)

Bidder's Offer No. \_\_\_\_\_

Date: \_\_\_\_\_

**Restrictions on procurement from Bidders from a country or countries, or class of countries under Rule 144(xi) of the General Financial Rules 2017.**

"We have read the clause regarding restrictions on procurement from Bidder of a country which shares a land border with India; and solemnly certify that we are not from such a country or, if from such country, we are registered with the Competent Authority (copy enclosed). We hereby certify that we fulfill all requirements in this regard and are eligible to be considered."

Penalties for false or misleading declarations:

We hereby confirm that the particulars given above are factually correct and nothing is concealed and also undertake to advise any further changes to the above details. We understand that any wrong or misleading self-declaration by us would be violation of Code of integrity and would attract penalties as mentioned in this tender document, including debarment.

\_\_\_\_\_  
(Signature with date)

\_\_\_\_\_  
(Name and designation)

Duly authorized to sign Bid for and on behalf of

\_\_\_\_\_  
(Name & address of the Bidder and Seal of Company)

# **(This need to be printed in Tenderer's letter head)**

---

## **Annexure-III**

### **Undertaking**

To,

The Purchase Officer  
Institute for Plasma Research  
Near Indira Bridge  
Bhat  
Gandhinagar-382428 (INDIA),

**Ref: Tender Notice No. IPR/TN/PUR/TPT/ET/21-22/036 dated 30-12-2021**

Dear Sir,

I / We have gone through the tendering conditions pertaining to the Two Part Tender and General Conditions of Contracts and Special Conditions of Contracts contained in Section "B" of Form No: IPR-LP-ET-02.V5. I/We hereby agree to supply the stores conforming to the tender specifications and also agree to abide by your General Conditions of all Contracts and Special Conditions of Contract contained in Section "B" of the Tender document.

- You will be at liberty to accept any one or more of the items of stores offered by us and I/We shall be bound to supply you the stores as may be specified in the Purchase Order/Contract.
- I/We hereby agree to keep the price valid for your acceptance for a period of 120 days from the date of opening of the tender.
- Deviations to technical specifications of the tender documents are detailed in Annexure-A of the tender form while deviations proposed to the General/Special Conditions of Contract are detailed in Annexure "B" to this tender.
- Standard equipments / accessories included in the bids shall be procured from OEM or their authorised agents. Any of the offered standard bought out equipment is not refurbished.
- I/We have also uploaded all the leaflets / catalogue, etc. pertaining to the stores offered.

Yours faithfully

Stamp and Signature of the Tenderer

**Institute for Plasma Research**  
**(An Aided Institute of Dept. of Atomic Energy)**  
**Bhat, Gandhinagar**

**Annexure - IV**

<b>IPR Enquiry NO &amp; Date</b>	<b>IPR/TN/PUR/TPT/ET/21-22/036 DATED 30-12-2021</b>
<b>COMMERCIAL TERMS &amp; CONDITIONS</b>	
<b>ITEM DESCRIPTION</b>	<b>Design, Manufacturing, Inspection, Testing, FAT, Supply and SAT of Double walled bellows at Institute for Plasma Research, Gandhinagar as per the detailed specifications mentioned in the tender documents.</b>

SI. No.	PARTICULARS	REMARKS
I	<b>Name of the Bidder</b>	
II	<b>Bidder Offer No. &amp; Date</b>	
III	<b>Postal address</b>	
IV	<b>Contact No. with STD Code</b>	
V	<b>Fax with STD Code</b>	
VI	<b>Name of Contact person</b>	
VII	<b>Mobile No.</b>	
VIII	<b>E-mail ID</b>	
IX	<b>Currency of offer/quotation</b>	INR
	<b>Commercial Terms for Quoted items (Please Provide Commercial terms and conditions in the below form)</b>	
1	Confirm the offered Price shall be firm and fixed through out the currency of contract, in the event of placement of purchase order.	
2	Price Term:	FOR IPR Gandhinagar
3	<p><b>Goods and Services Tax:</b></p> <p><b>Goods and Service Tax for Supply Items only:</b> IPR is entitled to avail GST Concessional Rate as per Ministry of Finance Notification No. 47/2017 Integrated Tax (Rate) dated 14/11/17 (for IGST) and (CGST @ 2.5% and SGST @ 2.5%) as per Notification No. 45/2017-Central Tax (Rate) dated 14/11/17 and Notification No. 45/2017-State Tax (Rate) dated 15/11/17</p> <p><b>Confirm that in the event of issuance of GST Concessional Certificate you shall charge GST on Supply Portion @5% only</b></p> <p><b>Goods and Service Tax for Service items: As applicable</b></p>	
4	<b>COMPLETION PERIOD: Refer Tender Document.</b>	

5	<b>Installation and commissioning charges</b> : Have you offered Installation & Commissioning Charges? <b>(if applicable)</b>	
6	<b>Liquidated Damages:-</b> Please confirm that the Liquidated Damages as per Sr. No. 22 of Section B of Form No IPR-LP-ET-02.V5 ( Terms and Conditions) attached with the tender/enquiry is acceptable to you	
7	Terms of Payment:- as per Sr. No. 35 of Section B of Form No. IPR-LP-ET-02.V5 (Terms and Conditions) attached with the tender/enquiry. (Also refer document named "Deferred_terms_IPR-LP-ET-02.V5" for amended terms)	
8	Guaranty / Warranty:-as per Sr. No. 34 of Section B of Form No. IPR-LP-ET-02.V5 (Terms and Conditions) attached with the tender/enquiry. (Also refer document named "Deferred_terms_IPR-LP-ET-02.V5" for amended terms)	
9	<b>Validity of offer/quotation:-</b> Refer tender terms	
	<b>QUESTIONNAIRE TO BE FILLED BY BIDDER IN AND SENT ALONG WITH OFFER DULY SIGNED</b>	
10	In the event of a purchase order/contract vendor has to provide Security Deposit in the form of Bank Guarantee for 3% of contract/ order value from State Bank of India or any Indian Nationalized/ Scheduled Banks as appearing in the second schedule of Reserve Bank of India (other than co-operative and Grameen Banks) on a non-judicial stamp paper of appropriate value valid till at least 2 months beyond the final acceptance of the supplied goods at IPR, wherever applicable shall be submitted .	
11	In the event of a purchase order/contract Performance Bank Guarantee for 3% of the contract/order value from State Bank of India or any Indian Nationalized/ Scheduled Banks as appearing in the second schedule of Reserve Bank of India (other than co-operative and Grameen Banks) on a non-judicial stamp paper of appropriate value till 2 months beyond the expiry date of warranty period , wherever applicable shall be submitted.	
12	I/We hereby offer to supply the stores detailed in the schedule hereto at the price given in the said schedule and agree to hold this offer open till expiry of quotation. I/We shall be bound to supply the stores hereby offered upon issue of purchase order communicating the acceptance thereof on or before the expiry of the last mentioned date. You will be at liberty to accept any one or more of the items of stores tendered for or portion of any or more of the items of such stores and I/We notwithstanding that the offer in the tender has not been accepted in whole shall be bound to supply to you- such item or items and such portion or portions of one or more of the items as may be specified in the said Purchase Order communicating the acceptance.	
13	Whether All Documents Related to tender Viewed?	
14	Vendor should upload the complete technical details (Technical specifications with product data sheet	
15	<b>Free Issue Material:</b> Successful tenderer will have to arrange insurance showing beneficiary as "Institute for Plasma Research" at their risk and cost towards adequate security for the materials/property provided/issued by the Purchaser as Free Issue Material for the due execution of the contract, wherever applicable.	

*(To be printed in letter head)*

---

**ANNEXURE-V**

**BID SECURITY DECLARATION**

**IN LIEU OF SUBMISSION OF EARNEST MONEY DEPOSIT (EMD)**

**Ref: (1) Our Offer No. .... dated .....**

**(2) Your Tender No. IPR/TN/PUR/TPT/ET/21-22/036 dated 30-12-2021**

---

In the event of withdrawing or modifying our offer within the validity or extended validity period, we hereby accept the suspension of our company for a period of two years from the date publication of this tender for your future requirement.

---

**Signature with date:**

**Name:**

**Designation:**

**Official Seal**

**SECTION 'C'**  
**TECHNICAL SPECIFICATIONS**  
**OF**  
**STORES AND DRAWINGS**

# Institute for Plasma Research

(An Aided Institute of Dept. of Atomic Energy)  
Bhat, Gandhinagar

## Eligibility Criteria (Annexure-A)

Sr. No.	Name of the Criteria	Detailed Criteria	Documents required to submit / upload
1	Technical competence and work experience	Bidder shall have at least 5 years (from the date of publication of the tender) of experience in regarding execution of: 1. Design of bellows by EJMA or EN or other equivalent standard 2. Manufacturing & Supply of bellows of size at least 1.5m diameter 3. Fatigue cycle test of bellows of size at least 1.5m diameter  Note: The past experience in the design and manufacturing of bellows shall be of bidder only and sub-contracted activities are not permitted.	Executed Purchase Order(s) unpriced copies/ Work Orders unpriced copies with Work completion certificates  And  Documentary evidence showings relevant experience in design, fabrication and supply as evident in copy of P.O / W.O. scope of work details
2	Quality Management System	Bidder shall have their own Quality Management System (QMS) in place or shall have valid ISO 9001:2015 (or later) certification.	Relevant document(s) that provides evidence of having own QMS in place (approved quality manuals etc.) or valid ISO 9001-2015 (or later) certification
3	Financial	Bidder should have an average annual turnover of ₹ 2.29 Crores or more for the last three financial years (FY 2018-19, 2019-20 & 2020-21).	Audited annual accounts OR CA Certificate to be uploaded
<b>Note:</b>			
a	The response to tender without submission of proof of above points will summarily be rejected without further communication		
b	The bidder shall not be under a declaration of ineligibility for corrupt or fraudulent practices or blacklisted with any of the Government agencies		
c	Original documents shall be produced for verifications, if required		



<b>Title</b>	<b>Prototype Development of Double Walled Bellows</b>
<b>Sub Title</b>	<b>Technical Specifications</b>

**Institute for Plasma Research  
Bhat, Gandhinagar 382428  
Gujarat, India**





1	Table of Contents	
<b>1</b>	<b>SCOPE OF THIS DOCUMENT</b>	<b>3</b>
<b>2</b>	<b>BACKGROUND</b>	<b>3</b>
<b>3</b>	<b>CODES &amp; CLASSIFICATION FOR THE BELLOWS</b>	<b>3</b>
<b>4</b>	<b>CONFIGURATION OF BELLOWS</b>	<b>4</b>
<b>5</b>	<b>THE SCOPE OF WORK</b>	<b>4</b>
<b>6</b>	<b>SCOPE OF SUPPLY (= LIST OF DELIVERABLES)</b>	<b>4</b>
<b>7</b>	<b>INPUT DOCUMENTS PROVIDED BY IPR</b>	<b>5</b>
<b>8</b>	<b>DELIVERY PERIOD</b>	<b>6</b>
<b>9</b>	<b>DESIGN</b>	<b>6</b>
9.1	GEOMETRY	6
9.2	MATERIAL	6
9.3	LOADS	10
<b>10</b>	<b>MANUFACTURE</b>	<b>14</b>
10.1	FORMING OF THE BELLOWS	14
10.2	WELD JOINT CONFIGURATION OF EXPANSION JOINT	14
10.2.1	Bellows	14
10.2.2	Bellows attachment welds	14
10.2.3	Welds on flanges connecting the bellows	14
10.3	ASSEMBLY SEQUENCE OF EXPANSION JOINT	14
10.4	WELDING OF EXPANSION JOINT	19
10.4.1	Weld plan	19
10.4.2	Welding Procedure Specification (WPS)	20
10.4.3	Welding Procedure Qualification Record (WPQR)	20
10.4.4	Extent of approval	20
10.4.4.1	Material Group	20
10.4.4.2	Welding Process	20
10.4.4.3	Welding Position	20
10.4.4.4	Welding Consumables	20
10.4.4.5	Range of approval of Welded joints	21
10.4.4.6	Thickness Range	21
10.4.5	Non –Destructive Examination	21
10.4.5.1	Personnel Qualification	21
10.4.5.2	Examination	21
10.4.5.3	Acceptance criteria	22
10.4.6	Destructive Tests	24
10.4.6.1	Test Specimen	24
10.4.6.2	Test Results	24
10.4.7	Welder and operator Qualification	25
10.4.8	Repair by welding of production welds	25



10.4.9 Helium leak testing of production of welds .....25

**11 TYPE TESTING.....25**

11.1 PRESSURE TESTING.....25

11.2 FATIGUE LIFE TESTING .....26

11.3 HELIUM LEAK TESTING .....26

**12 DIMENSIONAL INSPECTION .....27**

**13 CLEANING.....27**

13.1 CLEANING PROCEDURE FOR THE BELLOWS .....27

**14 PACKAGE & DELIVERY .....27**

14.1 TRANSPORT TOOL .....28

**15 DOCUMENTS FROM CONTRACTOR.....29**

**16 LIST OF FAT & SAT .....30**

**17 DELIVERY ADDRESS .....30**

**18 ANNEXURE.....31**

18.1 ANNEXURE II: SAMPLE MIP TEMPLATE .....31

18.2 ANNEXURE IV: DEVIATION REQUEST TEMPLATE .....32

18.3 ANNEXURE NON CONFORMANCE REQUEST TEMPLATE .....33

Figure 1 Interspace monitoring concept .....7

Figure 2 Double Wall Single Expansion Joint (EJ-1).....7

Figure 3 Double Wall Single Expansion Joint (EJ-2).....8

Figure 4 Double Wall Universal Expansion Joint (EJ-3) .....9

Figure 5 Exploded View of double wall universal expansion joint.....15

Figure 6 Proposed Transport fixture/Tool .....29



## 1 Scope of this document

This document specifies the technical specification for the prototyping of double walled bellows of size nearly 2m nominal diameter, forming a ultra-high vacuum barrier and capable of absorbing movements in all the three direction. The bellows is constructed of relatively thin gauge material in order to provide the flexibility needed to absorb displacements due to mechanical and thermal load expected in service. The objective is to develop a configuration which is not a conventional industrial practice in which the bellows are connected to adjoining components through butt joint weld with 100% volumetric examination. The purpose of this document is to specify scope of procurement covering design, manufacturing, quality, handling, inspection & test procedures etc. The manufacture design shall be done by supplier to ensure that the design comply with loading conditions as per the code as well as other requirements defined in this specification.

## 2 Background

Tokamak are being built across the world to develop power using fusion reactions. It consists of large toroidal vacuum vessel which forms the primary confinement for fusion reaction and containment of plasma. The vacuum vessel contains many openings called ports through which systems are connected which are required for producing, controlling, monitoring the plasma and its reactions. These adjoining systems need protection from large induced forces due to rigid displacements of vacuum vessel during plasma operations. This is realized by means of bellows.

The bellows not only accommodate the displacement but also act as a vacuum barrier and shield radioactive release. On the other hand, due to the presence of high temperature and water cooled components adjacent to bellows, there is a possibility for pressurization during the leakage accident. These bellows shall withstand to postulated accidents without losing the confinement and maintain the high quality vacuum ( $10^{-7}$  to  $10^{-4}$  Pa – base pressure). Therefore, the component comes under safety important class and design shall also accommodate accidental overpressure and high temperature.

To meet the above requirements, a double wall design configuration confining primary vacuum formed by the two co-axial circular cross-section bellows with interspace vacuum pumping and monitoring between the walls is required.

The present prototype of double walled bellows is expected to demonstrate the manufacturing feasibility, qualification to meet the functional requirements and demonstrate the reliability under various loading conditions.

## 3 Codes & Classification for the Bellows

The design and manufacturing shall be according to **EN14917:2009+A1:2012** and present specification document. Where this document is more stringent than standard, this document takes precedence.



#### 4 Configuration of bellows

It consists of two co-axial universal type bellows connected with the flanges at the ends. Each universal bellows configuration consists of two bellows connected by a center spool. As per vacuum and safety requirements, each bellows shall be single ply only and each weld joint shall be of full penetration. Bellows shall be of Hydrostatic, rolling or elastomeric formed.

#### 5 The scope of work

The main scope of work of the tender includes, but not limited to, the following tasks –

- a. Validate the basic configurational design available from IPR w.r.t EN147:2009+A1:2012 for all load cases given section 9.3. An additional design check for fatigue life shall be performed by the contractor based on the fatigue life curve prescribed by nuclear code (ASME Sec- III/RCC-MRx) for the bellows EJ-3. The data curve of it will be supplied by the IPR during the execution of project.
- b. Contractor have to assess the configuration from the manufacturability and feasibility point of view. Should there be any point of modification which vendor may feel, the same shall be brought to the notice of IPR for the review and acceptance.
- c. Before fabrication of main components, supplier has to develop the methodology for weld sequencing (for long seam, convolutions to central spool cylinder, convolutions to end flanges) so that all the joints are 100% volumetric examinable.
- d. Supplier has to qualify welding as per as per section 10.4 and submit weld plan to IPR for the approval prior to execution of the work.
- e. After establishing the above weld configurations, Supplier shall submit the manufacturing and Inspection plan for the actual component to IPR for the approval.
- f. Supplier shall perform type test on the bellows according to section 11 of the specification and all the tests shall be witness by IPR.
- g. Design and manufacturing of Closure plates / blind flanges, Jigs, fixtures, tools, feed-through, blind flanges, O-rings/wire seals (Al/Cu), instrumentation tubes and other accessories required for in manufacturing, testing, handling, transport and delivery are included in the scope of work.
- h. Supplier shall submit the manufacturing drawings, manufacturing procedures, radiography test reports with films, material certificates – traceable to assemblies, dimension inspection reports and reports covering other inspection and testing.
- i. The supplier shall determine the actual spring rates of expansion joint at room temperature and estimate force required to compress the bellows (EJ-3) by 120 mm.
- j. Cleaning, pre-assembly, handling, packing, transport and delivery of the bellows to ITER-India lab at IPR is include in the scope of work.

#### 6 Scope of supply (= list of deliverables)

The scope of supply includes expansion joints as per following table. The expansion joint implies flexible part (i.e. bellows), flanges, central spool in case of universal type and tie rods if any. The Deliverables under B & E also includes the closure plates on both ends of expansion



joints (i.e. blind flanges), seals/O-rings, instrumentation fittings, fasteners (studs, bolts, nuts & washers).

Deliverables	Components	Quantity	Remark
A	Double wall Single Expansion joint (EJ-1)  (Dia ~ Ø300mm)	1 unit	After completion of all the NDTs including Pressure test, this deliverable shall be subjected to fatigue test till destruction and then to be delivered to IPR
B	Double wall Single Expansion joint (EJ-1)	4 units	After completion of all the NDTs including Pressure test, these deliverables shall be supplied to IPR.  No Fatigue test is to be performed on this bellows.
C	Double wall Single Expansion joint (EJ-2)  (Half size in length direction of EJ-3 (i.e. bellow with no. of convolutions equal to one side of central spool; No central spool)	1 unit	After completion of all the NDTs including Pressure test, this deliverable shall be supplied to IPR
D	Double wall universal Expansion joint (EJ-3)  (Diameter ~ Ø2000mm)	1 unit	After completion of all the NDTs including Pressure test, this deliverable shall be subjected to fatigue test till destruction and then to be delivered to IPR
E	Double wall universal Expansion joint (EJ-3)	1 unit	After completion of all the NDTs including Pressure test, these deliverables shall be supplied to IPR.  No Fatigue test is to be performed on this bellows.

Note: Tools, fixtures or accessories which are not be mentioned in the deliverable/specification list but are necessary for inspection, testing, handling, lifting, storing as well as for efficient functioning of the system shall be considered as part of scope of supply. If specific tools are necessary for handling, transportation etc. to ensure safe delivery, they shall be proposed and are included in the scope of work.

#### 7 Input documents provided by IPR

The following main input documents have been included in this tender documents please refer to annexures.

1. Basic Engineering Design - Drawings of Expansion joints



2. Sample MIP
3. DR-NCR format

## 8 Delivery Period

The schedule of completion period is as follows.

- a. The EN14917:2009+A1:2012 compliance design and manufacturing design shall be completed within 3 months from date of the award of LoI / contract
- b. Fabrications, testing, inspection, assembly, FAT, delivery and SAT shall be completed within 15 months from date of approval of Manufacturing drawings of bellows (EJ-1,2 &3)

## 9 Design

### 9.1 Geometry

Basic configurations is provided. Design and validation shall be performed by the contractor as stipulated in scope of work. Based on this, the changes, if any shall be brought to the notice of IPR for review and approval

Figure 1 shows the inner and outer bellows subject to differential pressure across the walls of the bellows (applicable to all types of bellows considered in this tender). Figure 2 shows the double wall single expansion joint (EJ-1). Figure 3 & 4 shows the prototype of double walled single expansion joint (EJ-2) and universal expansion joint (EJ-3) respectively.

The loads coming on the EJ-1 and EJ-3 is provided in section 9.3. The design withstanding these loads shall comply with EN14917:2009+A1:2012. No separate design calculation are required for EJ-2. It is same as that of single bellows (any one side of central spool) of EJ-3. The objective of EJ-2 is to demonstrate the manufacturing and assembly feasibility at half size (in length) before demonstrating full size EJ-3.

### 9.2 Material

The material of bellows and flanges is recommended to be 1.4307 (X2CrNi18-19) and physical properties for these materials are given in **EN 100028-7**.

Note: Vendor shall submit 3.1 material certificate of major raw materials to IPR for approval before start fabrication

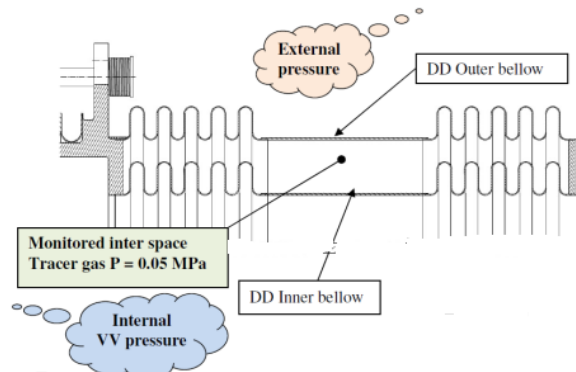
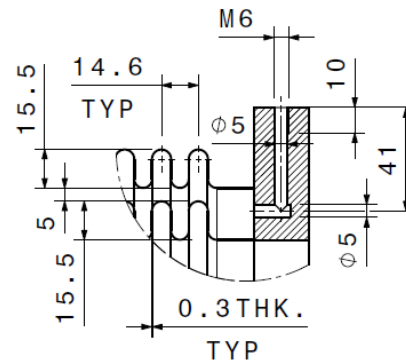
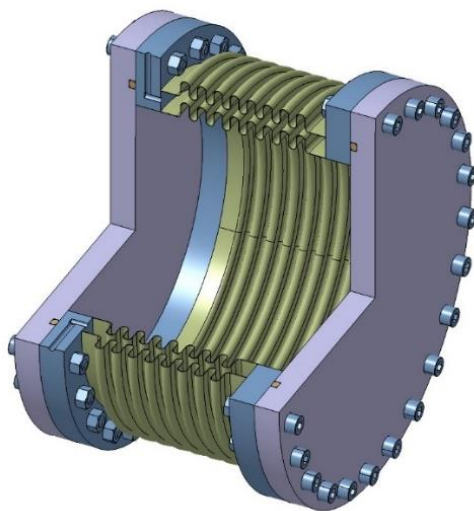

Figure 1 Interspace monitoring concept



Detail B  
Scale: 1:2

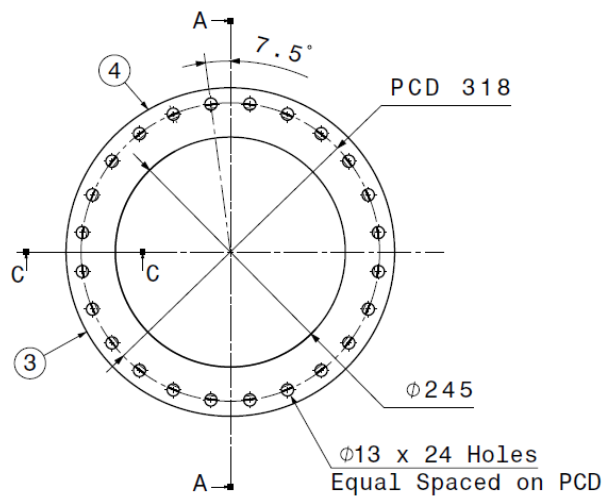
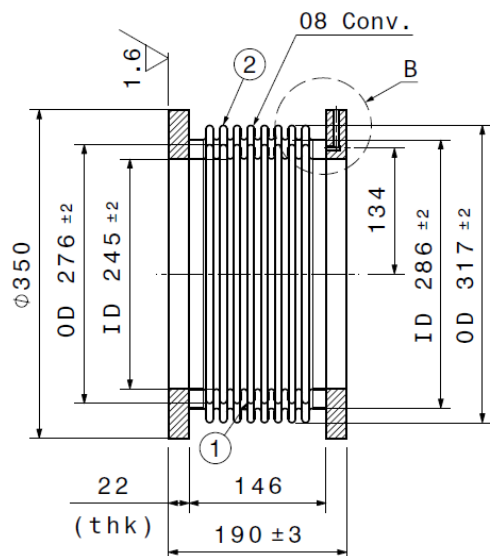

Figure 2 Double Wall Single Expansion Joint (EJ-1)



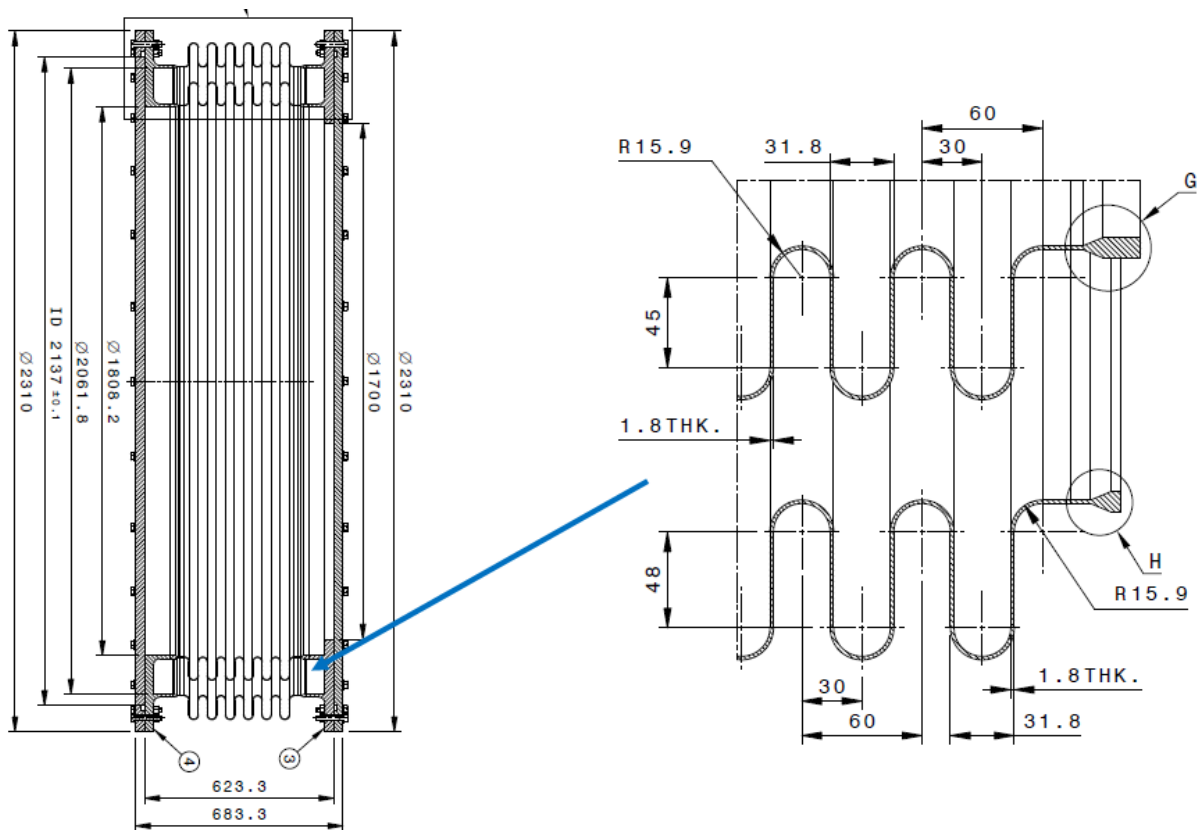
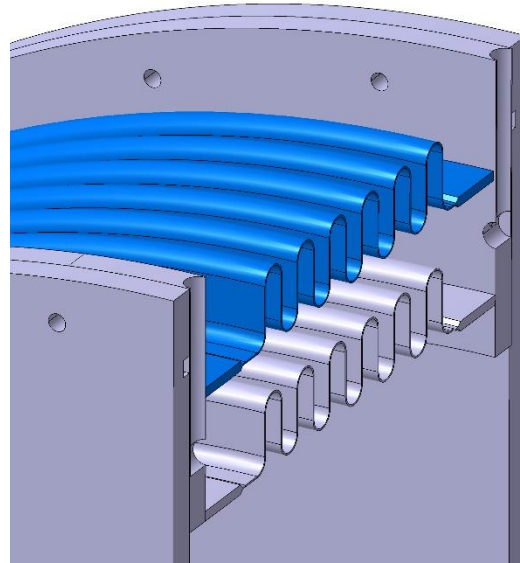
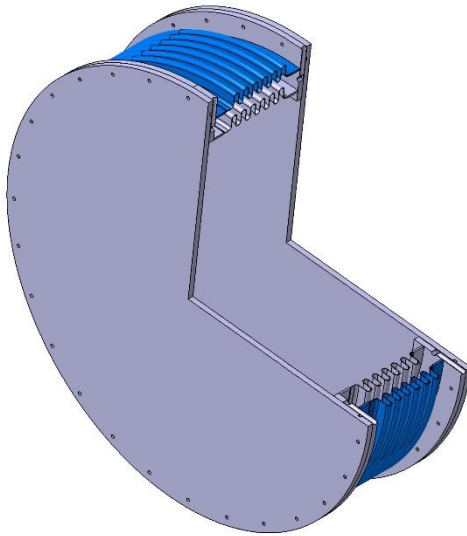

Figure 3 Double Wall Single Expansion Joint (EJ-2)

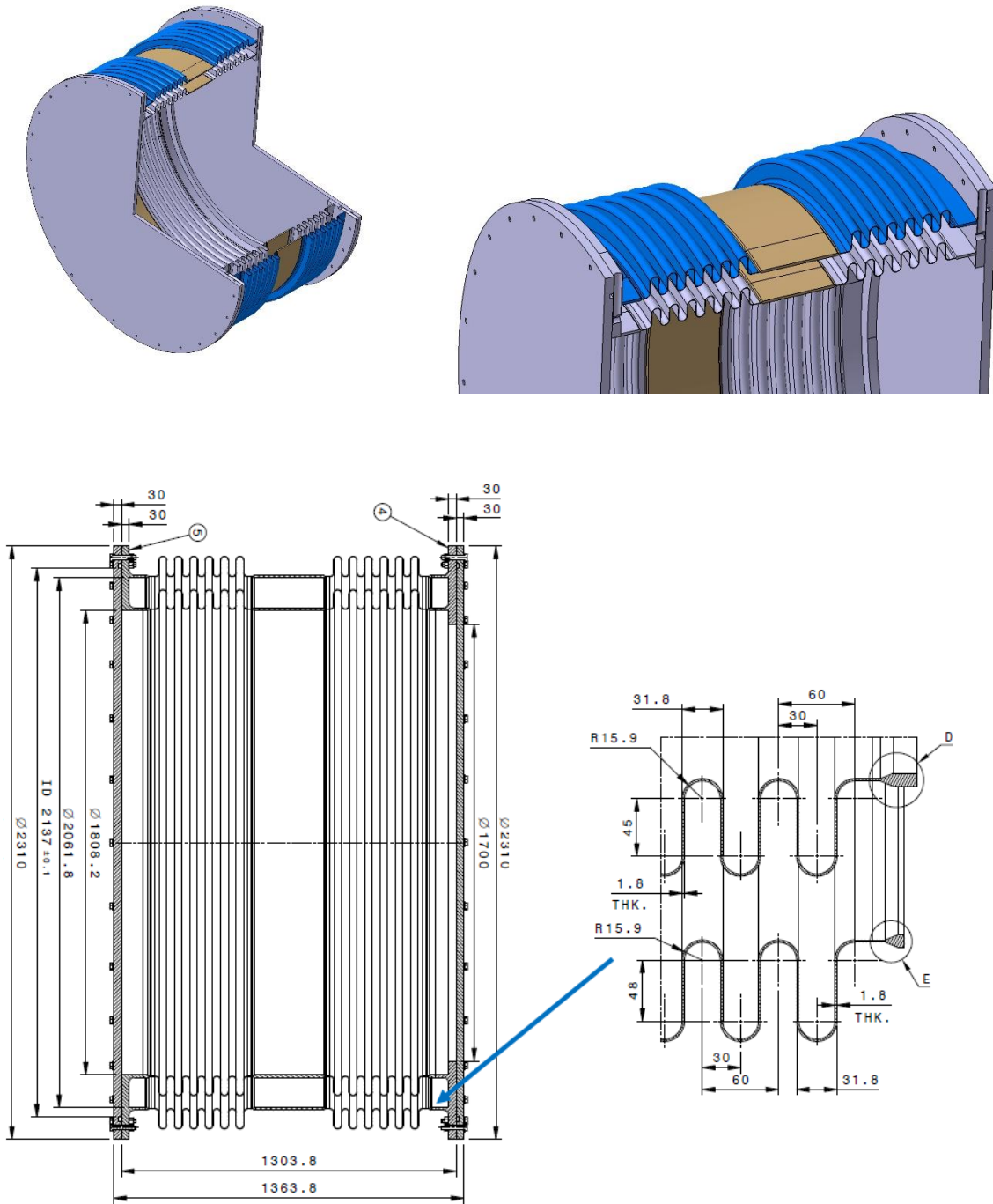

Figure 4 Double Wall Universal Expansion Joint (EJ-3)



### 9.3 Loads

1. Table 1 shows the all the values of displacement, pressure and temperature loads on the expansion joints (EJ-3). The loading conditions are categorized into four classes based on frequency of occurrences. Since the expansion joints are under safety important class, so the category II and IV subsumed in to I & III respectively.

Category I: Operating Loading Conditions; Category II: Likely Loading Conditions; Category III: Unlikely Loading Conditions; Category IV: Extremely Unlikely Loading Conditions

Table 1 Overall Loads on the Expansion Joint (EJ-3)

S.No	Event	Cat	Temperature	Pressure Inside VV	Pressure Interspace	Pressure NB Cell	Resultant pressure inner bellows	Resultant pressure outer bellows	N <sub>spe</sub>	X1 (Axial)	Y1 (Lateral)	θ1 (Angular)	Ø1 (Torsional)	X2 (Axial)	Y2 (Lateral) (Opposite to Y1)	θ2 (Angular)	Ø2 (Torsional)
Remarks			°C	Pressure Data (MPa); +ve means radially outwards					Cycles	Displacements Data (mm, mm, mrad, mrad)							
I-1	NO (dead weight)	I	No loads for calculation														
	Stand By (SB)	I	100	0.000	0.050	0.100	-0.050	-0.050	300	0.00	0.00	-	-	23.08	12.99	-	-
	NO (NB injection)	I	115	0.000	0.050	0.100	-0.050	-0.050	50000	23.08	12.99	-	-	26.54	14.94	-	-
	NO (coolant load)	I	No loads for calculation														
	NO (Nuclear heating)	I	No loads for calculation														
I-2	Baking	I	200	0.000	0.050	0.100	-0.050	-0.050	500	0.00	0.00	-	-	57.95	31.70	-	-
	Baking (Coolant loads)	I	No loads for calculation														
I-3	Maintenance (Draining & Drying)	I	20	0.100	0.100	0.100	0.000	0.000	3	23.08	12.99	-	-	123.08	0.00	-	-



	Assembly	I	Displacement load and pressure loads calculation are covered in maintenance														
	Lifting	I	Displacement load and pressure loads calculation are covered in assembly														
II-1	NO + VDE II	II	115	0.000	0.050	0.100	-0.050	-0.050	3300	26.54	14.94	-	-	38.63	26.84	-	-
II-2	NO + VV ICE II	II	250	0.110	0.050	0.100	0.060	-0.050	15	26.54	14.94	-	-	26.54	14.94	-	-
II-3	NO + VV ICE II + VDE II	II	250	0.110	0.050	0.100	0.060	-0.050	15	26.54	14.94	-	-	38.63	26.84	-	-
II-4	NO + SL-1	II	115	0.000	0.050	0.100	-0.050	-0.050	50	26.54	14.94	0.00	0.00	28.58	21.39	0.67	0.07
II-5	BAKING + SL-1	II	200	0.000	0.050	0.100	-0.050	-0.050	50	57.95	31.70	0.00	0.00	59.99	38.12	0.67	0.07
II-6	Maintenance (Draining & Drying) + SL-1	II	Displacement load and pressure loads calculation are covered in I-3														
	Assembly + SL-1	II	Displacement load and pressure loads calculation are covered in I-3														
	RH Lifting + SL-1	II	Displacement load and pressure loads calculation are covered in I-3														
II-7	NO + SL-1 + MDI	II	115	0.000	0.050	0.100	-0.050	-0.050	20	26.54	14.94	0.00	0.00	40.67	33.31	0.67	0.07
II-8	NO + LOCA NB II	II	112	0.000	0.050	0.130	-0.050	-0.080	20	26.54	14.94	-	-	26.54	14.94	-	-
III-1	NO + VDE III	III	115	0.000	0.050	0.100	-0.050	-0.050	1	26.54	14.94	-	-	49.51	38.75	-	-
III-2	NO + VV ICE II + VDE III	III	250	0.110	0.050	0.100	0.060	-0.050	1	26.54	14.94	-	-	49.51	38.75	-	-
III-3	NO + SL-1 + VDE II	III	Since VDE II = MDI, The case is covered in II-7														
III-4	NO + VV ICE III	III	250	0.150	0.050	0.100	0.100	-0.050	1	26.54	14.94	-	-	26.54	14.94	-	-
III-5	BAKING + VV ICE III	III	250	0.150	0.050	0.100	0.100	-0.050	1	57.95	31.70	-	-	57.95	31.70	-	-



Institute for Plasma Research

III-6	NO + VV ICE III + VDE II	III	250	0.150	0.050	0.100	0.100	-0.050	1	26.54	14.94	-	-	38.63	26.84	-	-
III-7	NO + LOCA NB III	III	118	0.000	0.050	0.160	-0.050	-0.110	1	26.54	14.94	-	-	26.54	14.94	-	-
III-8	NO + SMHV	III	115	0.000	0.050	0.100	-0.050	-0.050	1	26.54	14.94	0.00	0.00	30.92	28.85	1.44	0.15
III-9	BAKING + SMHV	III	200	0.000	0.050	0.100	-0.050	-0.050	1	57.95	31.70	0.00	0.00	62.33	45.53	1.44	0.15
III-10	Maintenance (Draining & Drying) + SMHV	III	Displacement load and pressure loads calculation are covered in I-3														
IV-1	NO + VDE IV	IV	115	0.000	0.050	0.100	-0.050	-0.050	1	26.54	14.94	-	-	49.51	50.89	-	-
IV-2	NO + VV ICE III + VDE IV	IV	115	0.150	0.050	0.100	0.100	-0.050	1	26.54	14.94	-	-	49.51	50.89	-	-
IV-3	NO + VV ICE IV	IV	250	0.200	0.050	0.100	0.150	-0.050	1	26.54	14.94	-	-	26.54	14.94	-	-
IV-4	NO + VV ICE IV + VDE III	IV	250	0.200	0.050	0.100	0.150	-0.050	1	26.54	14.94	-	-	49.51	38.75	-	-
IV-5	NO + SL-2	IV	115	0.000	0.050	0.100	-0.050	-0.050	1	26.54	14.94	0.00	0.00	32.54	34.03	1.97	0.21
IV-6	BAKING + SL-2	IV	200	0.000	0.050	0.100	-0.050	-0.050	1	57.95	31.70	0.00	0.00	63.95	50.68	1.97	0.21
IV-7	Maintenance (Draining & Drying) + SL2	IV	Displacement load and pressure loads calculation are covered in I-3														
	RH Lifting + SL-2	IV	Displacement load and pressure loads calculation are covered in I-3														
IV-8	BAKING + VV ICE IV	IV	250	0.200	0.050	0.100	0.150	-0.050	1	57.95	31.70	-	-	57.95	31.70	-	-
IV-9	NO + SL-1 + MD III	IV	No loads for calculation, no displacement data														



IV-10	NO + VV ICE IV + VDE IV	IV	250	0.200	0.050	0.100	0.150	-0.050	1	26.54	14.94	-	-	49.51	50.89	-	-
IV-11	NO + FIRE + SL-2	IV	300	0.000	0.050	0.100	-0.050	-0.050	1	26.54	14.94	0.00	0.00	32.54	34.03	1.97	0.21

2. The design loads on single bellow expansion (EJ-1) joint is as follows:

These bellows are mainly used for the purpose of alignment of vessel port and vacuum pump line. Once installed and assembled the bellows will be arrested with tie rods which are on mating flanges of bellows.

Table 2 Overall Loads on single bellow expansion (EJ-1)

S.No	Event	Temperature °C	Axial Displacement mm	Differ. Pressure MPa			Disp. Cycles
				External Pressure	Interspace Vacuum	Internal Vacuum	
1	RT	20	50 (Compression)	0.1	0.05	0	500
2	Baking	160	0	0.1	0.05	0	100



## 10 Manufacture

The manufacturer shall provide following documents as a part of quality control to guarantee the compliance w.r.t the specifications in fulfillment of the design criteria.

### 10.1 Quality Plan

### 10.2 Manufacturing and inspection plan

### 10.3 Manufacturing, testing and inspection procedures

### 10.4 NCR and DRs

## 10.1 Forming of the bellows

Bellows shall be manufacture by cold forming, e.g. hydraulic and similar process and roll forming. The forming processes used shall ensure a smooth profile, shall be free from scores, scratches or other stress raising defects and shall not affect the bellows resistance to corrosion. Forming of the bellows and the tolerances shall comply with the **EN14917:2009+A1:2012**.

## 10.2 Weld joint configuration of expansion joint

### 10.2.1 Bellows

Bellows shall be of single ply and contain only longitudinal butt weld without circumferential welds in the convolutions

### 10.2.2 Bellows attachment welds

The circumferential attachment welds of single ply bellows with its end fittings shall be of butt weld configuration as shown in figure below. The weld shall be 100% volumetric inspectable.



butt weld

### 10.2.3 Welds on flanges connecting the bellows

Any welds in the flanges exposed to the vacuum shall be 100% volumetric inspectable.

## 10.3 Assembly sequence of Expansion joint

The following images shows the proposal of assembly sequence based on feasibility of 100% volumetric inspection of all the weld joints exposed to vacuum environment. However, manufacturer based on own experience may offer alternate proposals to IPR for the considering and approval.

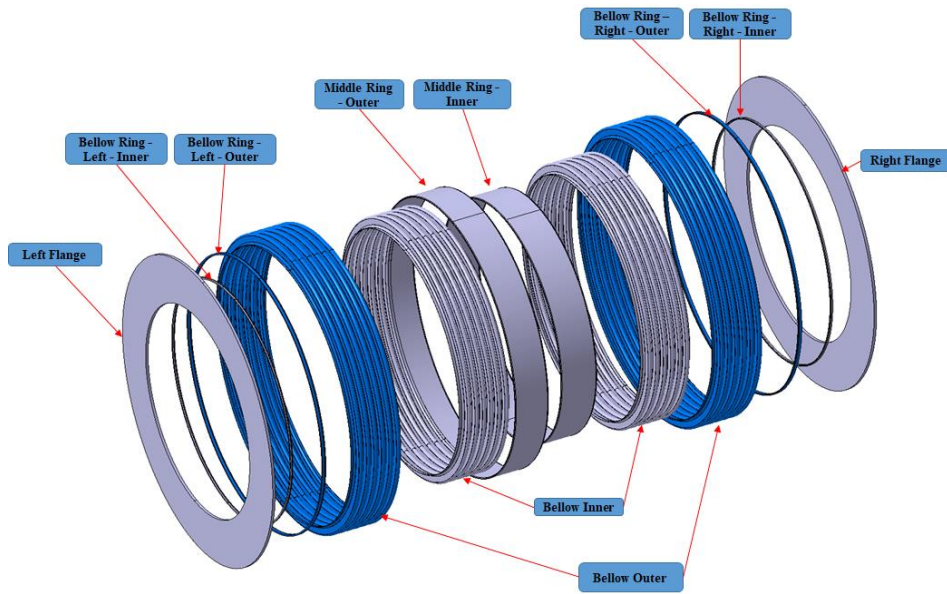
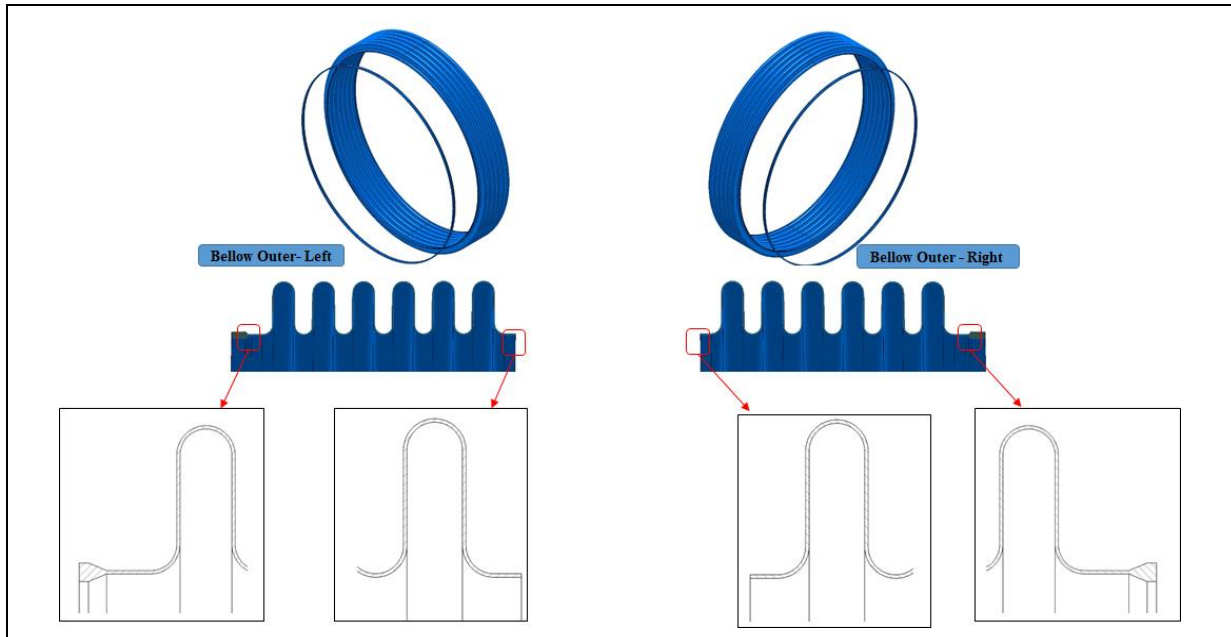

Figure 5 Exploded View of double wall universal expansion joint

Table 3 Proposed manufacturing and assembly sequence of Bellows

<p>Fabrication of center spool with edge preparation compatible to bellows – Outer</p>	<p>Fabrication of bellows with end tangents on both sides – 2 sets for outer side</p>





Fabrication of a dissimilar thickness ring and weld to one side of the bellows tangent (full penetration- 100% inspectable) for each outer bellows

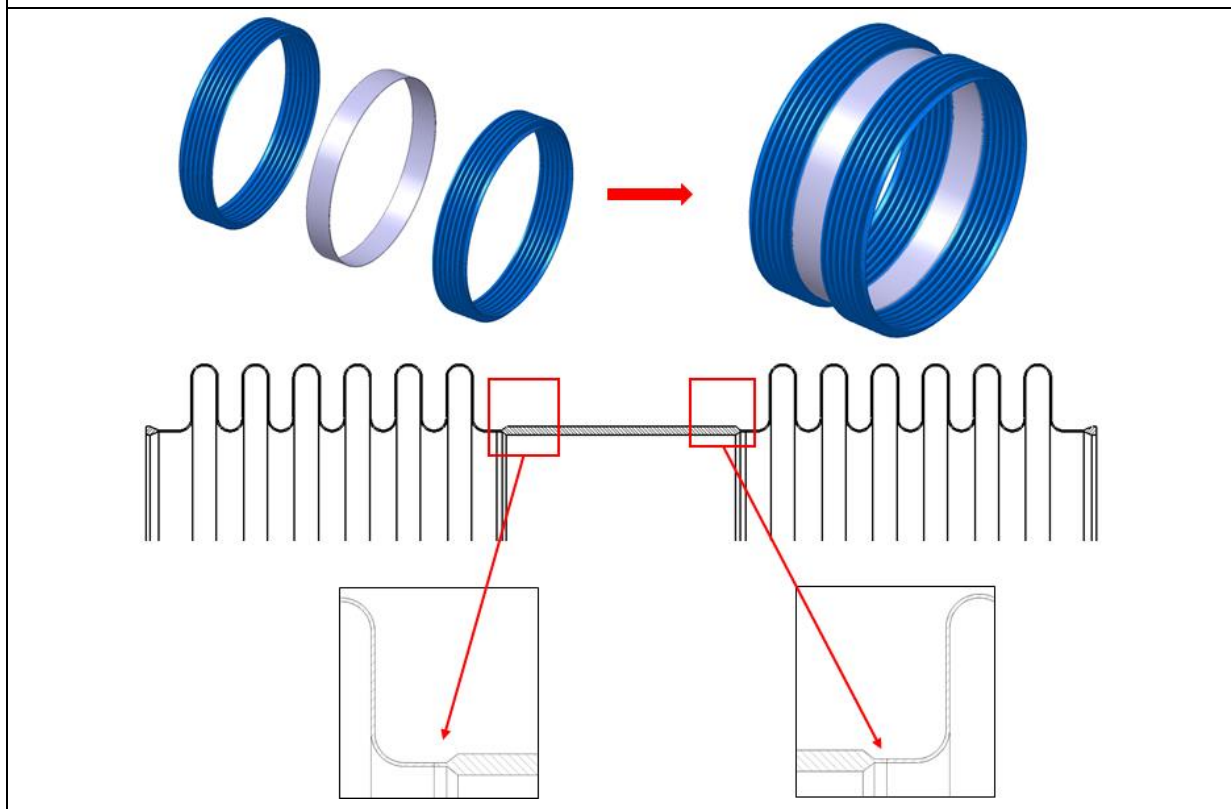

Join the central spool with each bellows at their tangents by butt weld joint – (full penetration- 100% inspectable)

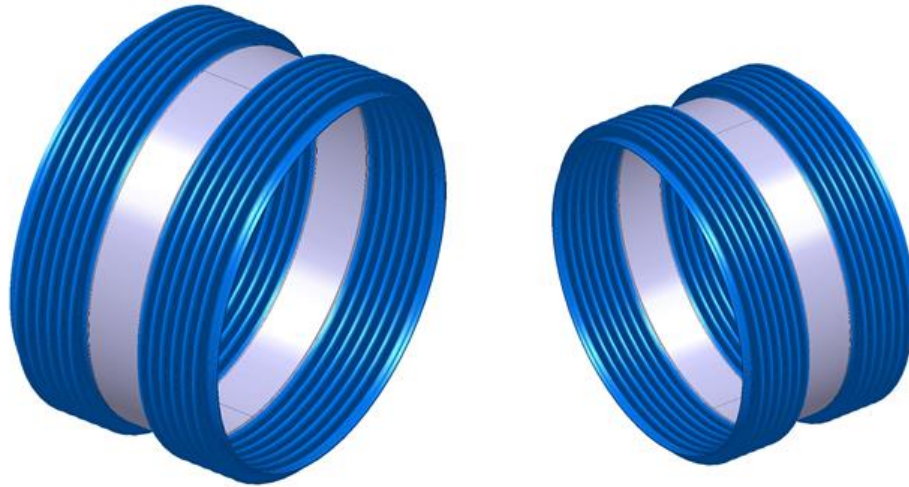

Outer Bellows

Inner Bellows

Fabricate inner bellows set similar to the outer bellows set

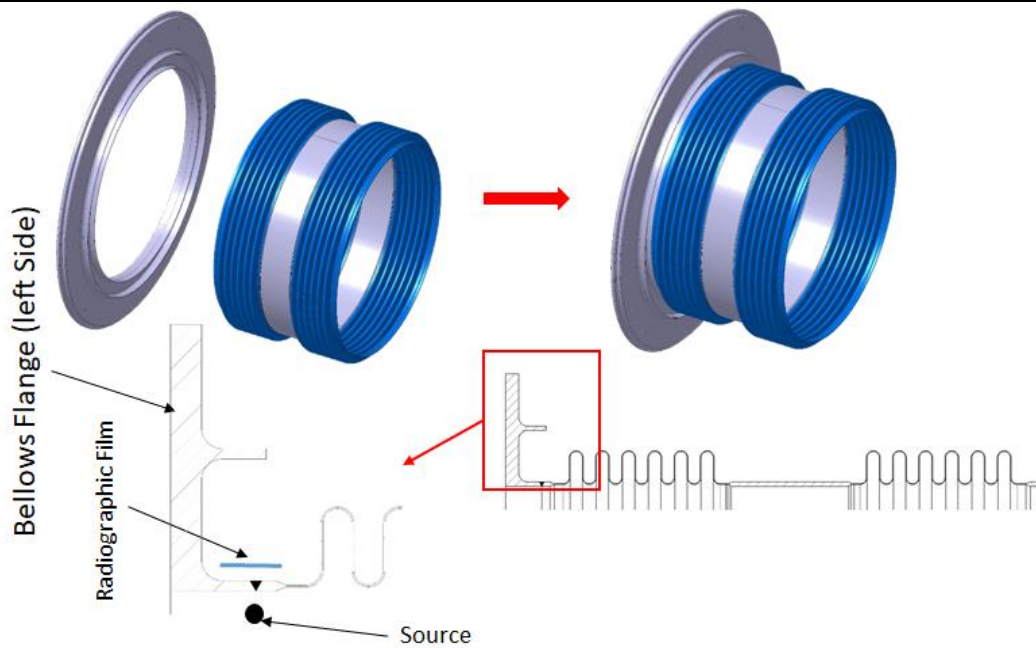

Joining of Bellows flange (left side) to inner bellows by welding (full penetration- 100% inspectable – two side accessible)

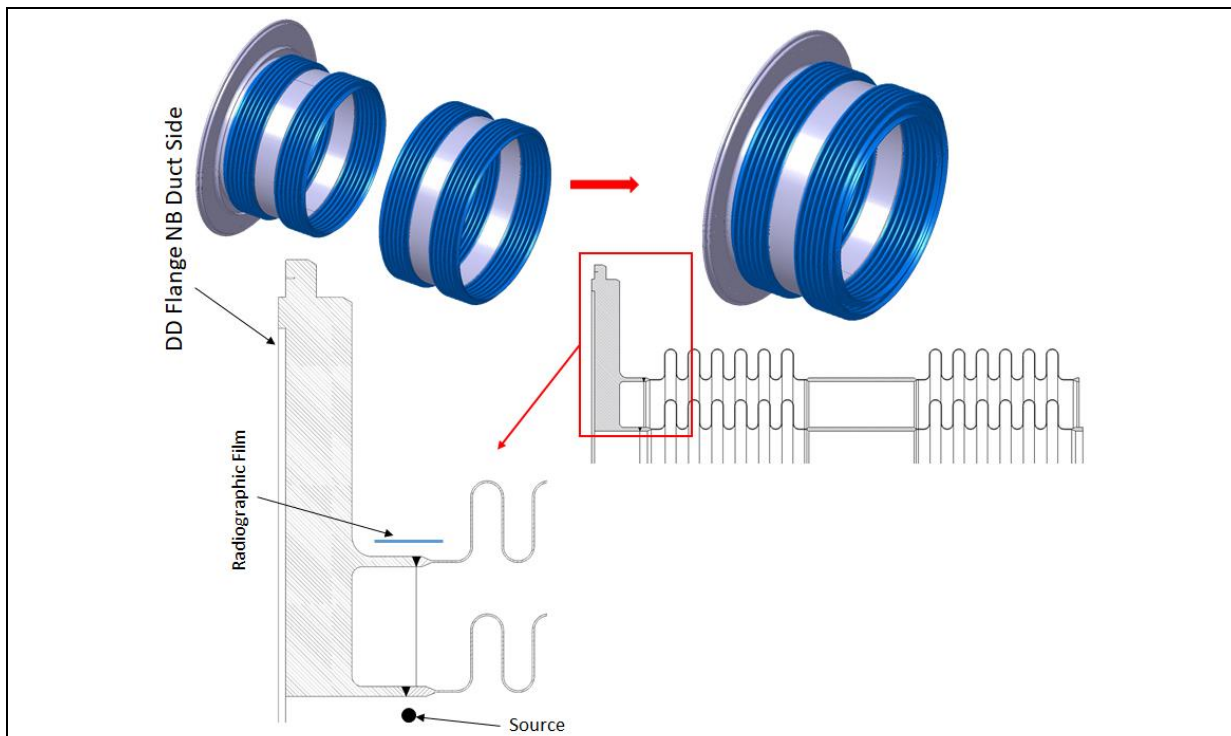

Joining of Bellows flange (left side) to outer bellows by welding (full penetration- 100% inspectable – one side accessible)

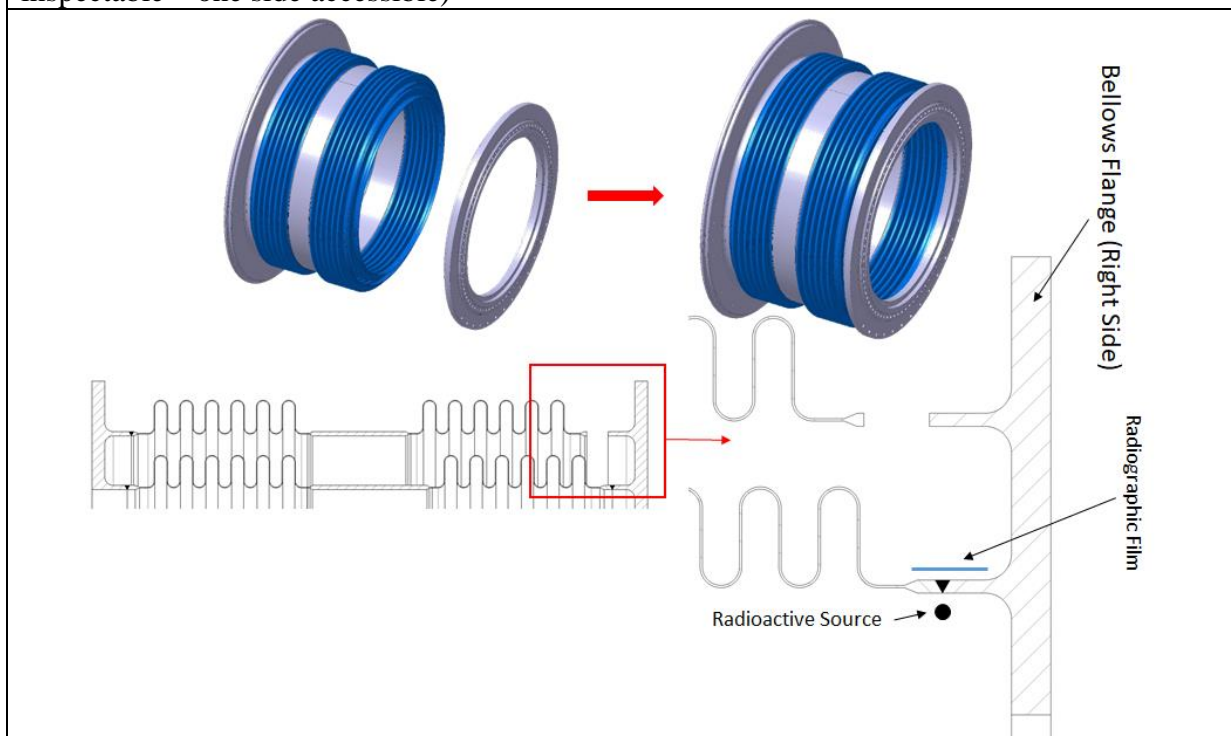

Joining of Bellows flange (right side) to inner bellows by welding (full penetration- 100% inspectable – two side accessible); In this stage, outer bellows need to be compressed for accessibility of weld joint in case of welding from outside.

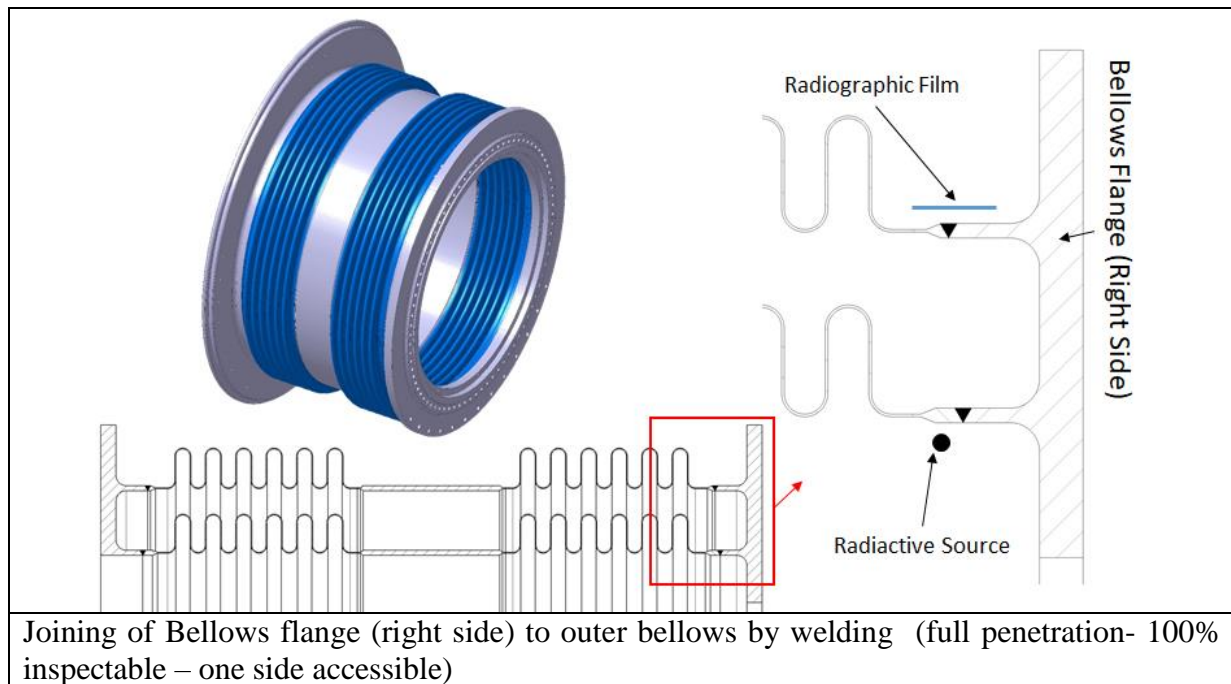

#### 10.4 Welding of expansion joint

The qualification, production and testing of welds of the expansion joint should be in accordance with the present document. In particular:

1. Supplier should prepare and submit the following documents for the approval wherever applicable:
  - a) Weld plans
  - b) WPS's
  - c) WPQR's and test reports
  - d) Welder qualification's and test reports
  - e) Production weld test reports
  - f) Reports on weld repairs
  - g) Non-Conformance Reports
2. 100% visual examination of production welds should be performed.
3. For all vacuum boundary welds, 100% volumetric examination of production welds should be performed.
4. Dye-Penetrant examination of production welds is only permitted with restriction according section 10.4.6.
5. Acceptable welding process for SS to SS material is TIG welding and the selected welding technique should produce a clean, defect free weld with minimal oxidation and distortion.

##### 10.4.1 Weld plan

Before commencing fabrication, the supplier shall prepare a weld plan for approval, in the form of drawing showing cross references for each weld-joint to a supporting Welding Procedure Specification (WPS).



#### 10.4.2 Welding Procedure Specification (WPS)

The WPS is a document which details all the variables which must be defined to produce acceptable quality weld. Each WPS shall detail each type of weld and other details accordance with **EN ISO 15609-1**.

#### 10.4.3 Welding Procedure Qualification Record (WPQR)

The WPQR is used to record all the relevant data from the welding of test pieces in the qualification of the WPS. The qualification of the WPS provides proof that the defined welding process, will achieve a weld of acceptable quality. The welding and testing of this must be witnessed by an **IPR representative**. All welding data and results from the non-destructive and destructive testing shall be documented using a WPQR. The WPQR shall be according to **EN ISO 15614-1**.

An existing Welding Procedure Qualification Record (WPQR) is acceptable if the following conditions are met:

- a) The test must have been performed in the same environment as proposed for production, using the same welding technique, process, joint configuration and welding equipment (for mechanized welds)
- b) The allowable ranges are the same with regard to essential variables.
- c) The related Preliminary Welding Procedure Specification (pWPS) has been qualified in accordance with **EN ISO 15614-1**.
- d) The test must have been witnessed by a recognized Independent Inspection Authority Weld produced for qualification must be performed by suitably skilled welders.

#### 10.4.4 Extent of approval

##### 10.4.4.1 Material Group

Material used for qualification shall be from the same group.

##### 10.4.4.2 Welding Process

In all cases, any change in the welding process will require a requalification of the process. In addition, in the case of automatic welding any change of the welding equipment will also require requalification.

##### 10.4.4.3 Welding Position

Welds for qualification shall be done in conditions similar to the conditions where the production weld will be made.

##### 10.4.4.4 Welding Consumables

All consumables shall be procured and certified to **ISO 14344**. In the case of manual welding processes, the approval range of filler material covers other filler metals as long as they are in the same range and chemical composition and Mechanical Properties.





In the case of automatic and semi-automatic welding processes the welding consumables used for qualification shall be the same batch as those used for production welds. Following any change occurring during production, weld samples shall be welded and examined prior to the continuation of production with the new batch of consumables. Qualification using filler does not qualify autogenously (fusion welding without filler material) welds or vice versa.

#### 10.4.4.5 Range of approval of Welded joints

The range of approval of welded joints shall follow the EN ISO 15614-1

#### 10.4.4.6 Thickness Range

The qualification of welding procedure test on the thickness  $t$  shall include qualification for thickness in the ranges according to **EN ISO 15614-1**

### 10.4.5 Non –Destructive Examination

#### 10.4.5.1 Personnel Qualification

The NDE operators, inspectors and engineers shall be trained and qualified to the appropriate level to meet the requirements of **EN ISO 9712 or ASNT** prior to performing or evaluating examinations.

The NDE personal shall also be qualified for any special technique or procedures to be followed as per the need of specification or drawing. Training and certification shall be responsibility of manufacturer and certification validity shall be as per relevant standards.

#### 10.4.5.2 Examination

After post weld heat treatment (if applicable) and prior to the cutting of the test specimen all test pieces shall be examined by the following.

Visual Examination	<b>EN ISO 17637</b>
Dye Penetrant Test <sup>§</sup>	<b>EN ISO 3452</b>
Radiographic Examination <sup>#</sup>	<b>EN ISO 17636-1</b>
And / or	
Ultrasonic Examination	<b>EN ISO 17640</b>

For a pipe or plate of 2mm or less wall thickness the method of examination shall be agreed prior to examination.

<sup>§</sup>LPT examination on the longitudinal butt weld after forming the corrugations of the bellows need to be performed at the outside crest to the maximum extend as per Table 8.4.4.3.2.1-1 of EN 14917:2009+A1:2012.

<sup>#</sup>The selection of the Radiographic or Ultrasonic examination method shall be based on following guidelines. Deviation from these guidelines is acceptable with prior approval and proper justification.



Wall Thickness (mm)	Preferred Volumetric Examination
$Wt < 8$	Radiography
$8 < Wt < 19$	Radiography & Ultrasonic
$Wt > 19$	Ultrasonic

### 10.4.5.3 Acceptance criteria

Defects which are detected by the relevant non-destructive examination method shall be assessed in accordance with **EN ISO 5817 level B**. In particular acceptance criteria are detailed in following table and it is in accordance with ISO 5817 and also contains additional requirements (highlighted in bold font) for production vacuum boundary welds.

Type of Imperfection		Permitted maximum
Designation	EN ISO 5817 Reference No.	
<b>Surface Imperfections</b>		
Cracks (all)	1.1	Not permitted
Surface pores	1.3	Not permitted
<b>Undercut</b>	<b>1.7</b>	<b>Not permitted, if <math>0.5 \leq t \leq 3\text{mm}</math>; Intermediate undercut is permitted when <math>t &gt; 3\text{mm}</math> and depth not to exceed <math>0.05t</math>, but max. <math>0.5\text{mm}</math>; undercut to blend smoothly with the parent material</b>
Shrinkage groove	1.8	Not permitted, if $0.5 \leq t \leq 3\text{mm}$ ; Short imperfection is permitted when $t > 3\text{mm}$ and depth not to exceed $0.05t$ , but max. $0.5\text{mm}$ ; smooth transition is required with the parent material.
Excessive weld metal (but weld)	1.9	<b>Not greater than 10% weld width</b>
Excessive convexity	1.10	$h \leq 1\text{mm} + 0.1*(b)$ , but max $3\text{mm}$ .
Excess penetration	1.11	$0.5 \leq t \leq 3\text{mm}$ : $h \leq 1\text{mm} + 0.1b$ ; $t > 3\text{mm}$ : $h \leq 1\text{mm} + 0.2b$ , but max. $3\text{mm}$ ; $h$ & $b$ are height and width of excess penetration on back side of plate.
Overlap	1.13	Not permitted
Sagging, Incompletely filled groove	1.14	Not permitted, if $0.5 \leq t \leq 3\text{mm}$ ; Short imperfections: $t > 3\text{mm}$ : $h \leq 0.05t$ , but max. $0.5\text{mm}$ ; whichever is smaller; weld thickness shall not be less than the parent plate thickness.
Burn through	1.15	Not permitted
Root oxidation	-	Not permitted where a backing purge gas is specified in the WPS.
Excessive asymmetry of fillet welds	1.16	Unequal leg length should not exceed 20% of the fillet throat thickness.



Root concavity	1.17	Not permitted
Root porosity	1.18	Not permitted
Poor restart	1.19	Not permitted
Stray flash	1.22	Not permitted
Spatter	1.23	Not permitted
Torn surface	603	Not permitted, Note: reference is from EN ISO 6520-1.
Grinding mark	604	
Chipping mark	605	
Under flushing	606	
<b>Internal Imperfections</b>		
Gas pore	2.3	Max dimension of the area of the imperfections (inclusive of systematic imperfections) related to the projected area for single layer (multi-layer) $\leq 1\%$ (2%);  Max dimension of the cross-sectional area of the imperfections (inclusive of systematic imperfections) related to the fracture area (only applicable to test pieces: production test, welder or procedure qualification tests) $\leq 1\%$ ;  <b>Max dimension for single pore: <math>d \leq 0.2t</math>, but max 2mm, whichever is lower.</b>
Uniformly distributed porosity		
Cluster porosity	2.4	$d_A \leq 15\text{mm}$ or $d_{A, \text{max}} \leq w_p/2$
<b>Linear porosity</b>	<b>2.5</b>	<b>Not permitted</b>
<b>Elongated cavity wormholes</b>	<b>2.6</b>	<b>Not permitted</b>
Shrinkage Cavity (all)	2.7	Not permitted
Crater pipe	2.8	Not permitted
Solid inclusions Slag inclusions (all) Flux inclusions (all) Oxide inclusions	2.9	$h \leq 0.2t$ , but max 2mm, whichever is smaller.  In group, the aggregate length not to exceed $t$ in a length of $12t$ , except when the distance between successive indications exceeds $6l$ where $l$ is longest indication in the group.
Metallic inclusion other than Cu & W		
Copper Inclusions	2.11	Not permitted
<b>Tungsten Inclusions</b>	-	<b>Not permitted</b>
Lack of fusion (all)	2.12	Not permitted
Lack of penetration	2.13	Not permitted
<b>Imperfections in joint geometry</b>		
Linear misalignment	3.1	Not greater than 10% of the parent material thickness.





Multiple imperfections

Multiple imperfections in any cross-section	4.1	Not permitted  Max total height of imperfections: $\Sigma h \leq 0.2t$ , or $01.5a$
---	-----	--

10.4.6 Destructive Tests

The specimens that shall be subjected to destructive testing, testing procedures and results shall comply with **EN ISO 15614-1**.

10.4.6.1 Test Specimen

The number of test specimens that shall be subjected to destructive testing is given in the following table in accordance with **EN ISO 15614-1**.

Test Specimen	Nos. of tests
<b>Butt Weld</b>	
Transverse Tensile (Room Temp)	2
Root Bend (for $t < 12$ mm)	2
Face Bend (for $t < 12$ mm)	2
Side Bend ( for $t > 12$ mm)	4
Impact Test ( $t \geq 12$ mm, for one set for weld metal & one set from HAZ)	2
Macro Examination (With macrograph)	1
Micro Examination at 200X (With micrograph)	1
Hardness testing	1
Transverse tensile at design temperature	1
<b>Fillet Weld</b>	
Fracture Test	1
Macro Examination	4
Micro Examination at 200X	2
Hardness Survey	2
<b>T –Butt / Branch Weld</b>	
Macro Examination	4
Micro Examination at 200X	2
Hardness Survey	2
<b>Socket / Lip Weld</b>	
Macro Examination (with photograph)	4
Micro Examination at 200X	2
Hardness Survey	2

10.4.6.2 Test Results

Unless specified differently in below table, destructive testing and test results shall comply with **EN ISO 15614-1**.



<i>Bend test (stainless steel and nickel alloy only)</i>	<i>The bend angle shall be 180° round a former of diameter 2t, where t is the thickness of the specimen. The bend test specimen shall have no open defects exceeding 2 mm measured in any direction on the convex surface after bending.</i>
<i>Micro - Examination</i>	<i>In general micro-examination shall only be required for welds which form part of the vacuum boundary or are in contact with cryogenic liquids. If required micro-examination tests shall be specified in the technical specification.</i>
<i>Macro Examination</i>	<i>For lip welds, penetration shall be 0.7t where t is the thickness of the thinner material.</i>

#### 10.4.7 Welder and operator Qualification

The welder qualification is intended to show the competence of the welder/operator for implementing the specified WPS. Welder qualification shall be in accordance with **EN ISO 9606-1** or equivalent standards agreed in advance. For welding operators **EN ISO 14732** shall be used.

#### 10.4.8 Repair by welding of production welds

No weld repair shall be performed without qualification of the repair welding procedure. The repair weld procedure shall be proposed to the purchaser for review and approval.

Before repair, the size and magnitude of all leaks / unacceptable discontinuities found on welds forming a vacuum boundary shall be reported to purchaser.

#### 10.4.9 Helium leak testing of production of welds

All vacuum sealing welds shall be subjected to 100% leak tested as per section 11.3 of this specification.

The necessary fixtures, required to withstand the vacuum forces during evacuation, shall be designed, manufactured and integrated during the testing by manufacturer. The same shall also be supplied along with the delivery of bellows.

### 11 Type testing

After the completion of all manufacturing processes the bellows assemblies should undergo the following qualification tests.

#### 11.1 Pressure testing

Pressure testing of bellows will be according to EN14917.



## 11.2 Fatigue life testing

The *supplier* should demonstrate that the bellows assemblies will remain mechanically unaltered over the expected life. Fatigue life tests should be performed under load conditions given in section 9.3 for EJ-1 & EJ-3.

In case of double wall universal expansion joint (EJ-3) the test be performed as per following stages.

Stage 1: The test shall demonstrate the manufactured design of the bellows shall guarantee required fatigue cycles grouped under Category-I events.

Acceptance criteria for stage 1:

- No local or overall permanent deformation is allowed
- The bellow shall pass the He leak test as per 11.3

Stage 2: Once after the demonstrating minimum guarantee life level, the expansion joints further subjected to the displacement-fatigue grouped under category-III & IV events.

Acceptance criteria for stage 2:

- where local and overall permanent deformation are allowed however the location will be identified and measured for the record. Immediate fracture is not allowed and it may not possible to return to service after subjection of load.
- The bellow shall pass the He leak test as per 11.3

Stage 3: Once after the demonstrating the minimum life in the stage 2, the expansion joints further subjected to the most sever displacement load under category IV further till failure.

## 11.3 Helium Leak testing

The supplier should perform leak testing of the bellows assemblies. Acceptable leak rate ( $\text{Pa}\cdot\text{m}^3\cdot\text{s}^{-1}$  air equivalent) at maximum operating temperature  $< 1 \times 10^{-10}$ . The above values are applicable for both global and local leak rate - bellows interspace to atmosphere and bellows interspace to vacuum.

Bellows assemblies should be hot leak tested at the maximum operating temperature (250°C for EJ3 and 160°C for EJ1) as follows:

- Global test of bellows assembly
- Leak test of bellows interspace (to vacuum and to atmosphere)

He leak test shall be performed on the bellows in the following sequence:

Stage-1: Cold leak test at ambient temperature

Stage-2: Hot-leak test at operating temperature.

Stage-3: Cold leak test at ambient temp. This test shall be performed immediately after the cool down between 70 to 80 °C.

Note: Fixture design (carried out by contractor) required for holding bellows shall take care of forces raised due to differential pressure across flanges during evacuation and followed by He



leak test. The necessary fixtures, required to withstand the vacuum forces during evacuation, shall be designed, manufactured and integrated during the testing by manufacturer. The same shall also be supplied along with the delivery of bellows.

Some important examination and testing shall be witnessed by IPR. The detailed witness points will be defined in the Manufacture and Inspection Plan from bellows supplier (refer annexure 15.1). The inspection and test reports shall be submitted to IPR for approval.

## 12 Dimensional Inspection

The supplier shall perform a survey of the bellows convolutions to confirm compliance with the bellows technical specification and drawing. The tolerances shall be as per EN 14917. The survey results will be supplied to IPR and any non-conformance shall be assessed for its implications.

## 13 Cleaning

Great care has to be exercised when cleaning thin walled metal bellows. If any cleaning residues are trapped between the convolutions, either inside or outside, these can result in corrosion which can rapidly cause leaks to develop. Similarly, if any particulates are deposited in the convolutions, mechanical puncturing can take place. Alkaline degreasing solutions such as Almeco are prone to particulate precipitation and therefore must not be used for bellows assemblies.

### 13.1 Cleaning procedure for the bellows

The bellows should be fixed in an extended position if at all possible.

1. Any traces of visible, loose contamination should be removed with a jet of clean, dry air or nitrogen.
2. The bellows should be immersed in an ultrasonically agitated bath of isopropyl alcohol (IPA) or ethyl alcohol (ethanol).
3. The bellows should be vapor washed immediately in vapor of the same solvent.
4. The bellows, including the interspace where appropriate, should be thoroughly dried inside and out using a gentle jet of clean, dry, particulate free air or nitrogen.
5. The bellows should be placed in a dry air oven at least 100°C for at least 1 hour with the interspace vented and open to atmosphere.
6. The bellows should be sealed under dry nitrogen in a polyethylene bag.

## 14 Package & Delivery

Where practical, bellows assemblies should be entirely enclosed in heat sealed vacuum compatible polyethylene. Bellows inside should be backfilled to 0.12 MPa with the connections sealed by a closed valve. Nitrogen is preferred but other gasses may be accepted with prior acceptance of IPR. All bellows assemblies must be shipped dry internally and externally irrespective of final acceptance testing at the manufacturer's site.



The use of adhesive tape for the protection and packaging of components should be limited to prevent the risk of contamination from the tape. In particular tape used on austenitic stainless steel shall meet leachable chloride and fluoride limits of 15 ppm and 10 ppm, respectively. Where used tape must be fully removable, without residue, using isopropyl alcohol or acetone as the solvent

Where practical all bellows assemblies should be transported in rigid packing cases or containers which are lined with waterproof material. Components should be packed with adequate protection from thermal and mechanical stresses (particularly shock loads resulting from dropping and mal-handling) which may adversely affect the operation of the bellows. All packing case joints should be sealed and cases marked with bellows specific identification. Handling instructions should also be clearly marked on the outside of the packaging. Any chemical or radiological hazards, etc., must be identified on the packaging. All packaging markings should be in English.

#### 14.1 Transport Tool

Design of transport fixture/tool for the bellows is within in the scope of contractor. It shall have sufficient points for handling by crane. Contractor may propose to have a common fixture for handling, lifting, testing (including pressure and He leak test) and transport.

EJ-3 bellows shall be transported under compressed state i.e. by 120mm. The fixtures design shall accommodate to take this displacement.

A conceptual configuration shown in the figure 5 may be used in the design of fixture/tool. However contractor is free to propose other alternative design and submitted to of IPR for the approval. The tool/fixture consists of 2 U brackets linked by 10 M20 Tie Rods surrounding the DD bellows to provide full control over the movement. The brackets are clamped to bellows flanges on either side. These brackets shall structurally withstand to the reaction forces coming from the bellows spring rates for a compression of 120mm.

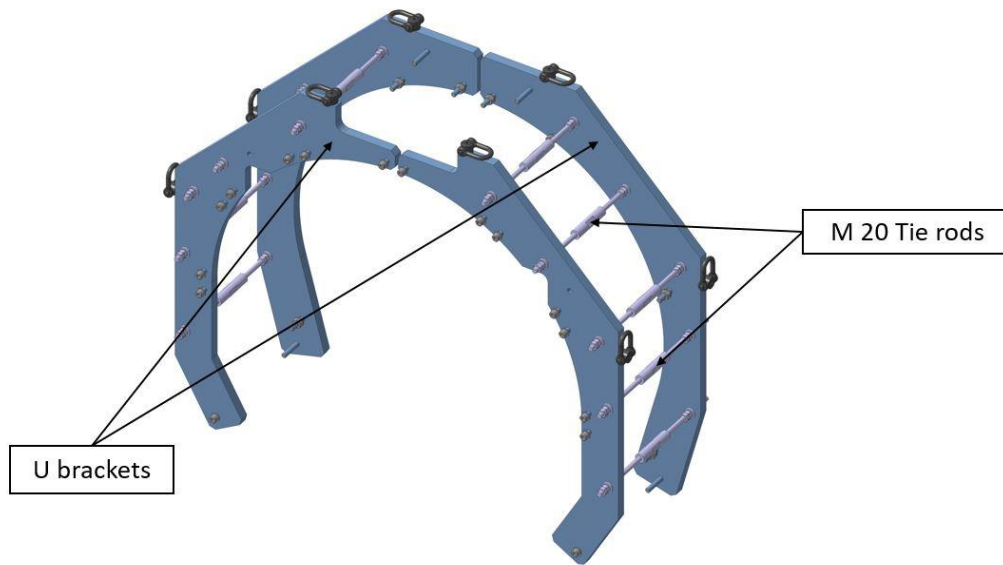

Figure 6 Proposed Transport fixture/Tool

15 Documents from Contractor

Following are the documents submitted by the contractor at different stage of contract.

Sl. No.	Document to be supplied
1*	Quality Plan <i>(Covers the whole scope of contract including the work of sub-contractors)</i>
2*	Manufacturing and Inspection Plan <i>(Covers the whole scope of contract including the work of sub-contractors)</i>
3*	Manufacturing Drawings <i>(Individual component, sub assembly &amp; final assembly)</i>
4*	Manufacturing Schedule
5	Non-conformance Reports
6*	Deviation Request if any
7*	Weld Plan
8	Welding Procedure Specification , Procedure Qualification Records & Welder Qualification Record
9	Weld Data sheets <i>(Detailing all the details like joint detail, welding process, welding parameters, inspection &amp; testing prior to, during and after welding etc.)</i>
10*	Manufacturing Procedures
	1. Material Identification , Traceability & Marking
	2. Cleaning Procedure
	3. Dimensional inspection procedure
	4. Helium Leak Testing Procedure



	5. Pressure Testing Procedure
	6. Fatigue Testing Procedure
	7. NDE procedures
	8. Handling, Packing & Transportation Procedure/Instructions
11*	Factory Acceptance Test Plan
12*	Site Acceptance Test Plan
13*	NDE Personnel Qualification
14	Inspection reports & Certificates like, Material Test certificate, Lab test certificates, Visual Examination reports, Dimensional Inspection reports, Non Destructive Examination reports, Production Proof Sample Examination reports, Cleaning Inspection reports, Special Test, Pressure Test reports, Leak Test reports etc.
15	As built drawings
16	Periodic work progress Report

\*Note: Documents required to be submitted for the review and approval before manufacturing by the contractor for Manufacturing Readiness Review (**MRR**). The MRR is intended to confirm that the manufacturer of the concerned component is ready to start without incurring unacceptable risks and to give the authorization to proceed with manufacturing.

#### 16 List of FAT & SAT

Sl. No.	Test & Document to be supplied by the contractor	
FAT		
1	Pressure Test and its Report	EJ-1, EJ-2 & EJ-3
2	He leak teat and its report	EJ-1, EJ-2 & EJ-3
3	Fatigue Test and its Report	EJ-1 & EJ-3
SAT		
1	Pressure Test and its Report	EJ-1, EJ-2 & EJ-3
2	He leak teat and its report	EJ-1, EJ-2 & EJ-3

#### 17 Delivery Address

DNB Lab – ITER-India building,  
Institute for Plasma Research  
Bhat, Gandhinagar, Gujarat -382428



18 Annexure

18.1 Annexure II: Sample MIP template

<b>Manufacturing and Inspection Plan</b>													
Document Number:								<b>Key</b>					
Contract No.								HP	Hold Point				
Description of MIP								W	Witness of Operation				
Supplier:								NP	Notification Point				
<b>Prepared by Contractor</b>			<b>Reviewed by IPR</b>			<b>Approved by IPR</b>			ATPP	Authorization to Proceed Point			
									R	Review Report Required			
									S2	Random Inspection			
									S1	100% Inspection			
				<b>Inspection Body</b>						<b>Revision No.:</b>			
exp. Date	Activity No.	Process	Specification, Procedure	Sup Contractor		Contractor		IPR		Others	Record	Remarks	NCR/DR





18.2 Annexure IV: Deviation Request Template

**Section 1** *To be completed by Contractor*

*Report No:*

1. IPR contract number:
2. Contract title:
3. Contractor:
4. Item identification :
5. Safety Important Component (SIC): Yes [ ]                      No [ ]                      NA [ ]
6. Original requirement:
7. Alternative proposal:
8. Justification:
9. List of attachments:

**Section 2** *To be completed by Contractor*

Contractor Responsible Officer	Contractor Quality Group
Decision	Comments
<i>Name:</i>	<i>Name:</i>
<i>Date:</i>	<i>Date:</i>
<i>Signature:</i>	<i>Signature:</i>

**Section 3** *To be completed by IPR*

IPR Responsible Officer	IPR Quality Group
Accept [ ]                      Reject [ ]	Comments
<i>Name:</i>	<i>Name:</i>
<i>Date:</i>	<i>Date:</i>
<i>Signature:</i>	<i>Signature:</i>



18.3 Annexure Non Conformance Request Template

Section 1 To be completed by Contractor

Report No:

1. IPR contract number:
2. Contract title:
3. Contractor:
4. Item identification :
5. Safety Important Component (SIC): Yes [ ] No [ ] NA [ ]
6. Original requirement:
7. Description of the non-conformance:
- 8 Non-conformance Category: Major [ ] Minor [ ]
9. Proposed remedial action: Use as is [ ] Rework [ ] Repair [ ] Reject [ ]
10. Justification:
11. List of attachments:

Section 2 To be completed by Contractor

Contractor Responsible Officer Decision  <i>Name:</i>  <i>Date:</i>	Contractor Quality Group Comments  <i>Name:</i>  <i>Date:</i>
<i>Signature:</i>	<i>Signature:</i>

Section 3 To be completed by IPR

IPR Responsible Officer Accept [ ] Reject [ ]  <i>Name:</i>  <i>Date:</i>	IPR Quality Group Comments  <i>Name:</i>  <i>Date:</i>
<i>Signature:</i>	<i>Signature:</i>

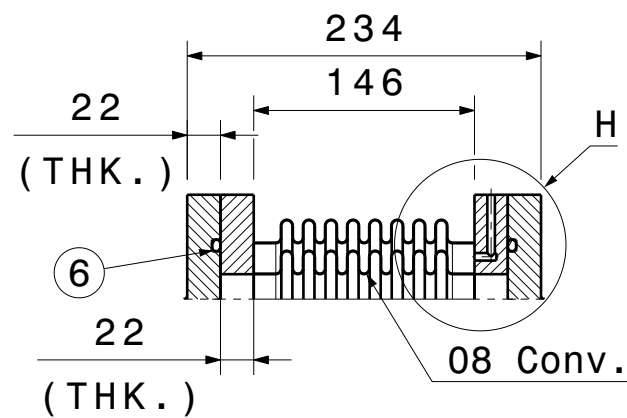

Section view F-F

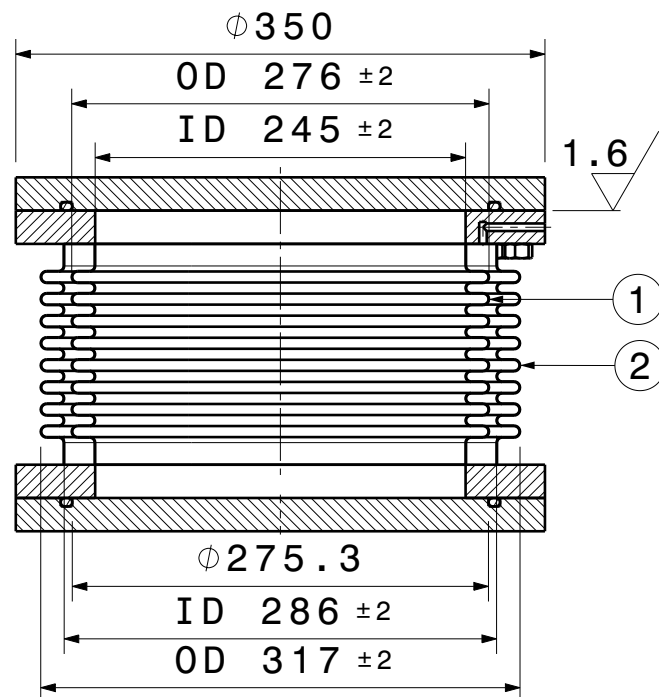

Section view G-G

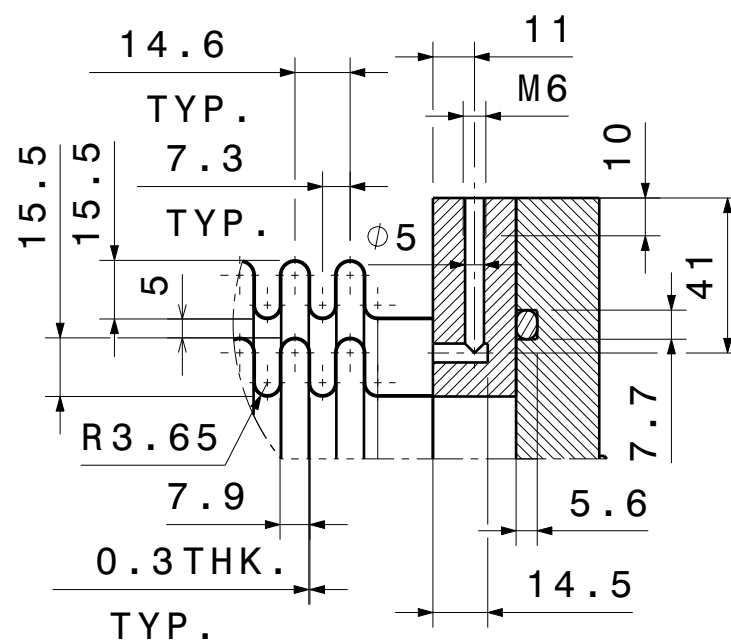

Detail H  
Scale: 1:2

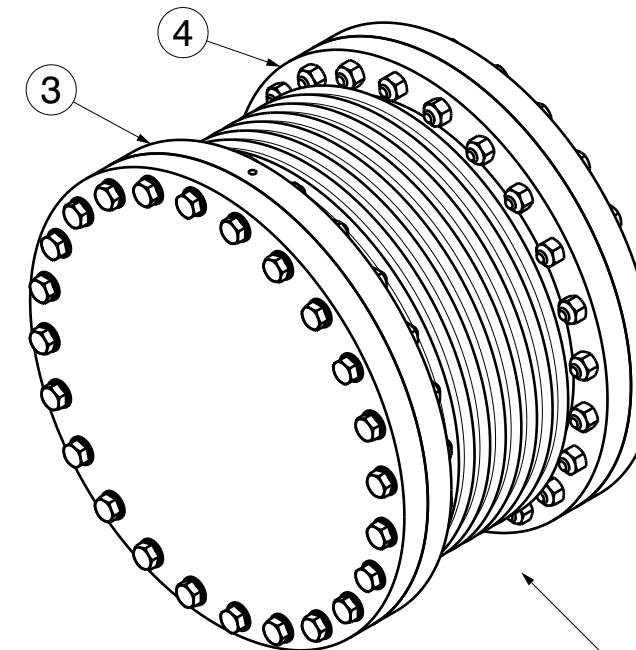

Isometric view

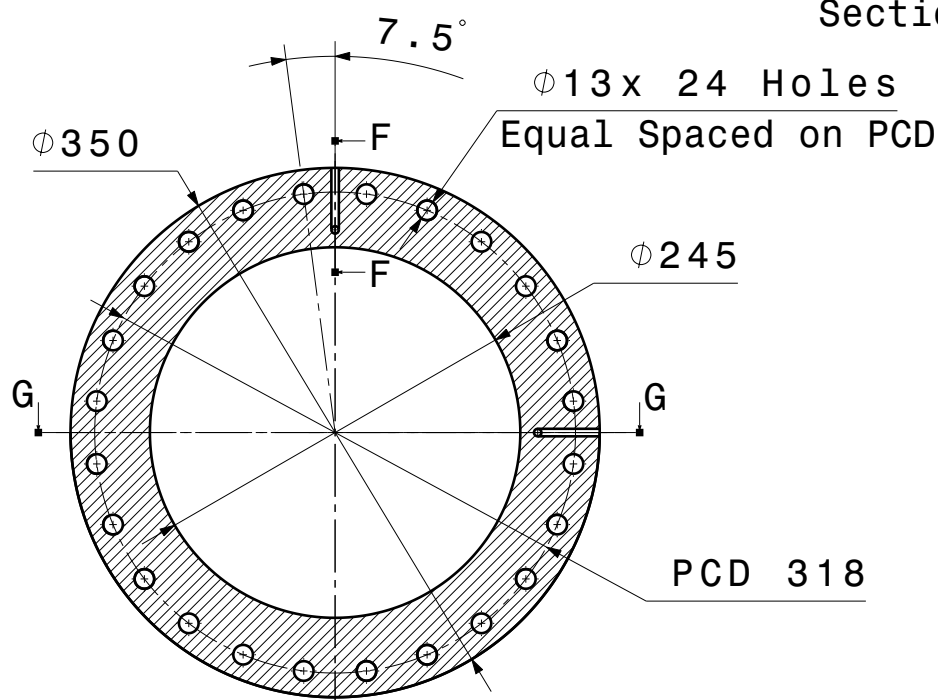

Section view E-E

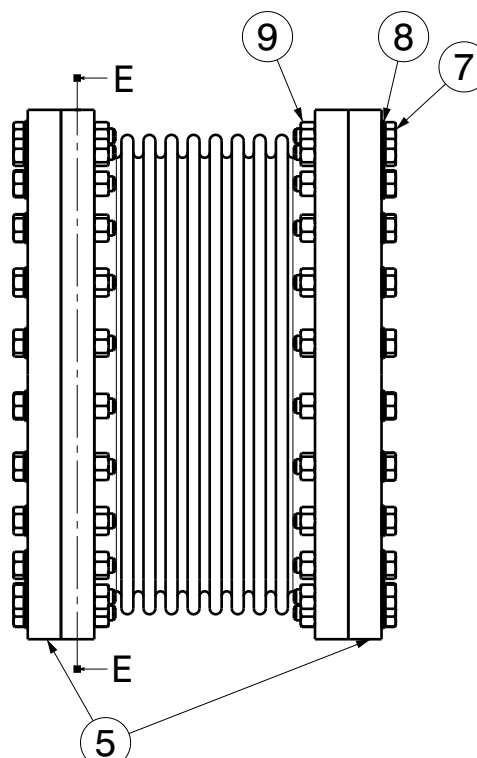

Front view

**DESIGN REQUIREMENTS :-**

STANDARD (DESIGN & MFG.) : EN14917  
 DESIGN PRESSURE : 1 BAR (ABS)  
 DESIGN TEMPERATURE : 20°C  
 COMPRESSION MOVEMENT : 50 mm  
 CYCLE LIFE : 500 CYCLES

**WORKING PRESSURE :-**

PRESSURE INSIDE INNER BELLOW : VACUUM  
 PRESSURE BETWEEN INNER AND OUTER BELLOW : 0.5 BAR (ABS)  
 AMBIENT PRESSURE : 1 BAR (ABS)

**GENERAL TOLERANCE:**

MACHINED PARTS: ISO 2768-mK  
 WELDED CONSTRUCTION: EN ISO 13920-BE  
 VACUUM CLASS: VQC-1A  
 SURFACE ROUGHNESS:  $\sqrt{Ra 6.3}$

NO.	DESCRIPTION	MATERIAL	QUANTITY
01	INNER BELLOW	1.4307	01
02	OUTER BELLOW	1.4307	01
03	FLANGE_01 (ISO F 200)	1.4307	01
04	FLANGE_02 (ISO F 200)	1.4307	01
05	BLANK FLANGE (ISO F 200)	1.4307	02
06	O-RING	-	02
07	ISO 4016 BOLT M10x60	1.4307	48
08	ISO 7089 WASHER 10x20	1.4307	48
09	ISO 4034 M10 NUT	1.4307	48

NOTE :-  
 1. ALL DIMENSIONS ARE IN millimeters UNLESS STATED.  
 2. DESIGN AND MANUFACTURING ACCORDING TO EN14917

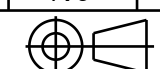
DRW DOC ID		RELEASED BY		
LINKED EV5 PT ID		IPR		
PBS TITLE		APPROVED BY		
REV DATE		CHECKED BY		CONFIDENTIAL UNLESS AUTHORISED The information on this drawing is confidential under the terms of the ITER-India agreement. This information shall not be transmitted to anyone who is not authorised to receive it. DRAWING TITLE <b>DOUBLE WALL SINGLE EXPANSION JOINT (EJ-1)</b>
DD MTH YR		JJ-DNB		
SHEET FORMAT		CONTROLLED BY		
A3		MVN-DNB		
THIRD ANGLE PROJECTION		DRAWN BY		NO OF SHEETS 01
		DT		
SHEET		NO OF SHEETS		PBS 3 LEVELS DRAWING NUMBER 1001-01
01		01		
NO OF SHEETS		REVISION		DR STATUS Z
01		NNN		

Spacreservation for the banner

Spacreservation for the banner

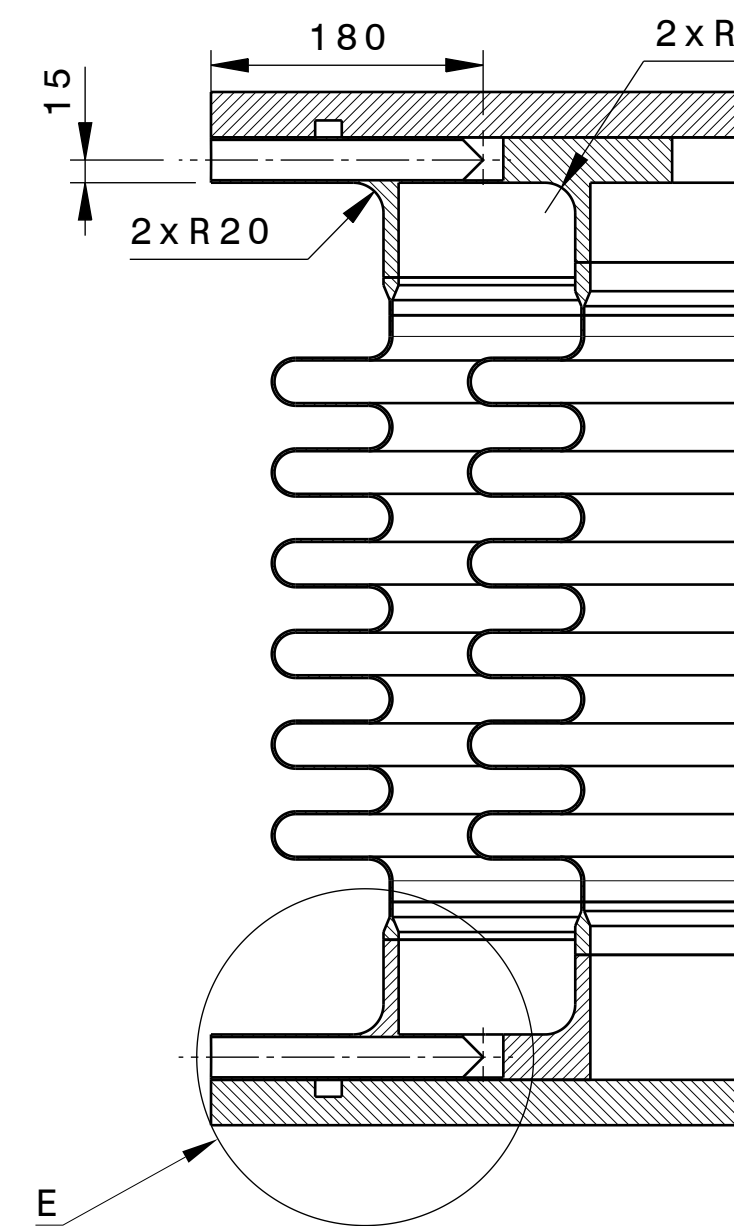

Section view B-B  
Scale: 1:5

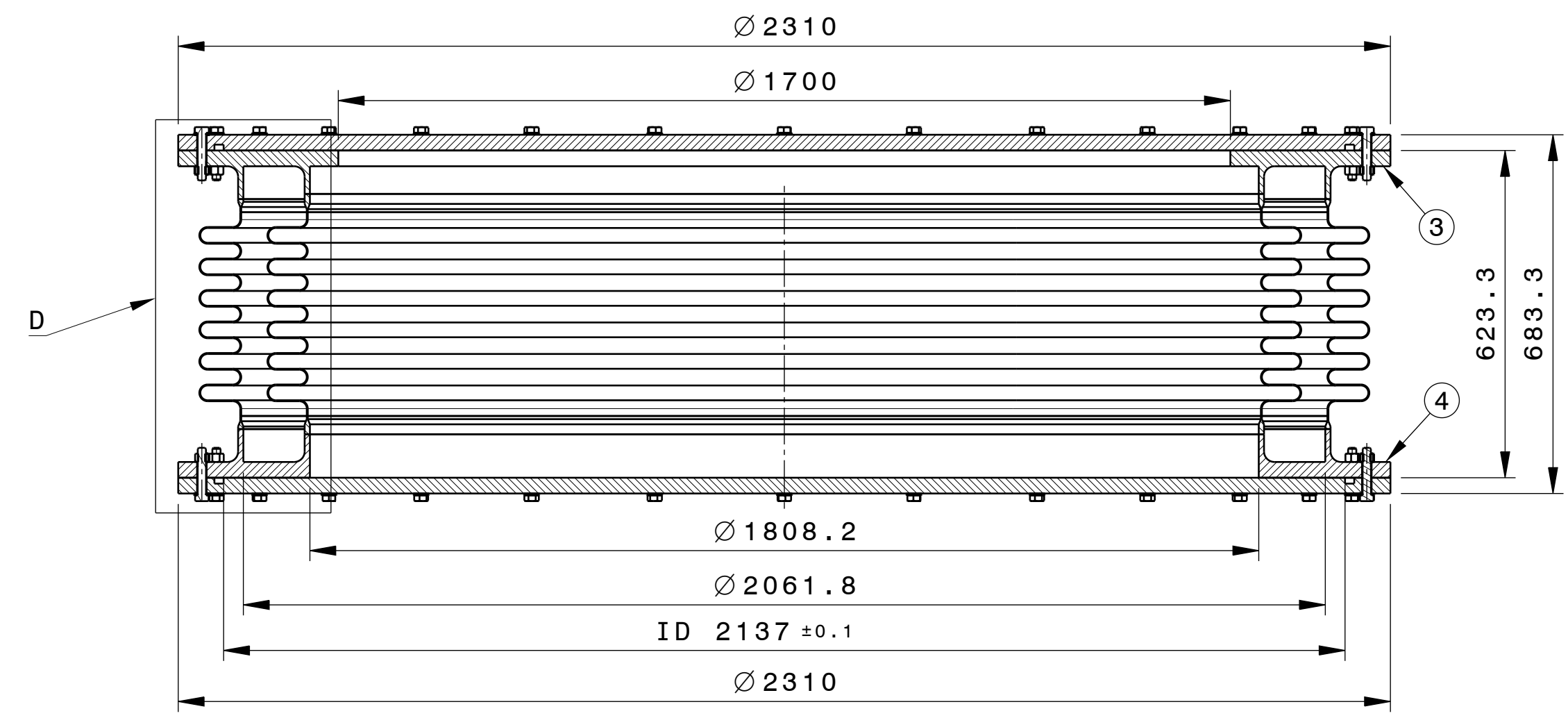

Section view C-C  
Scale: 1:10

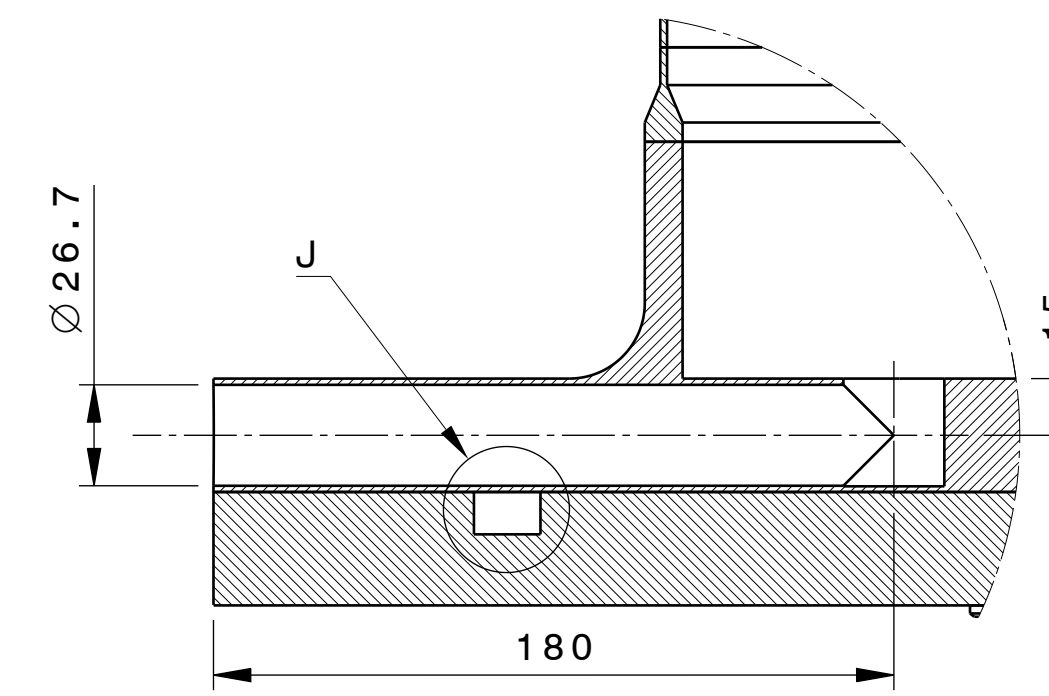

Detail E  
Scale: 1:2

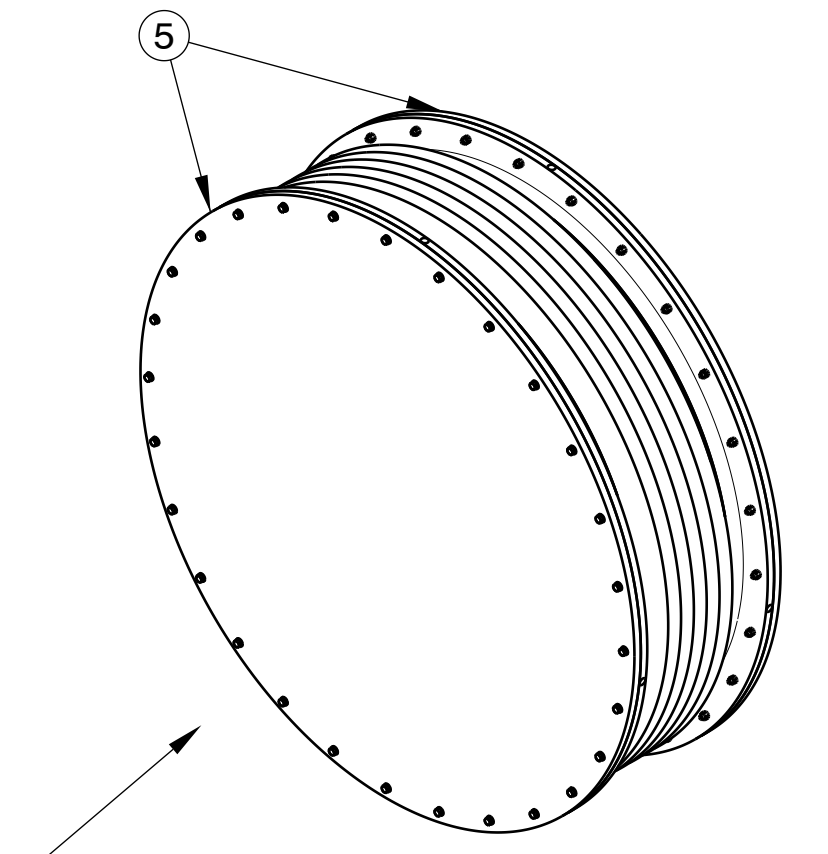

ISOMETRIC VIEW

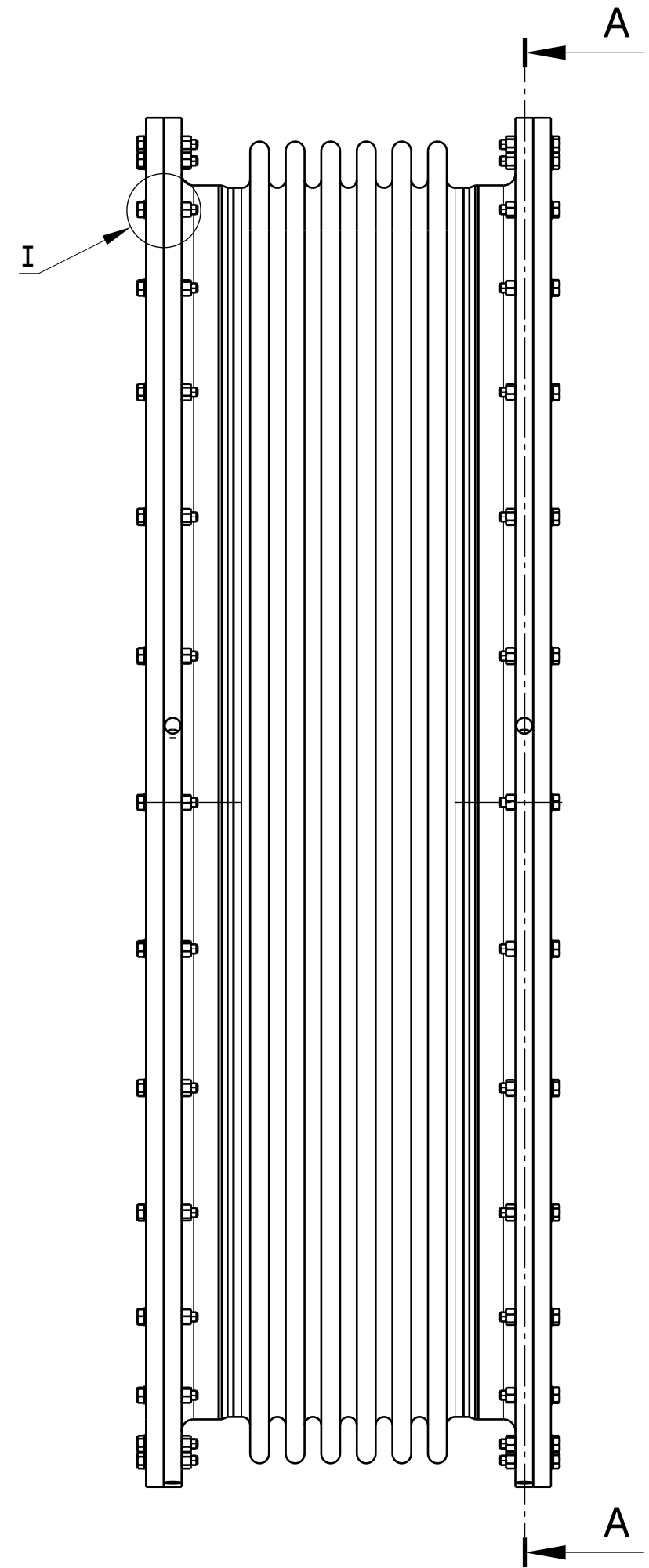

Front view  
Scale: 1:10

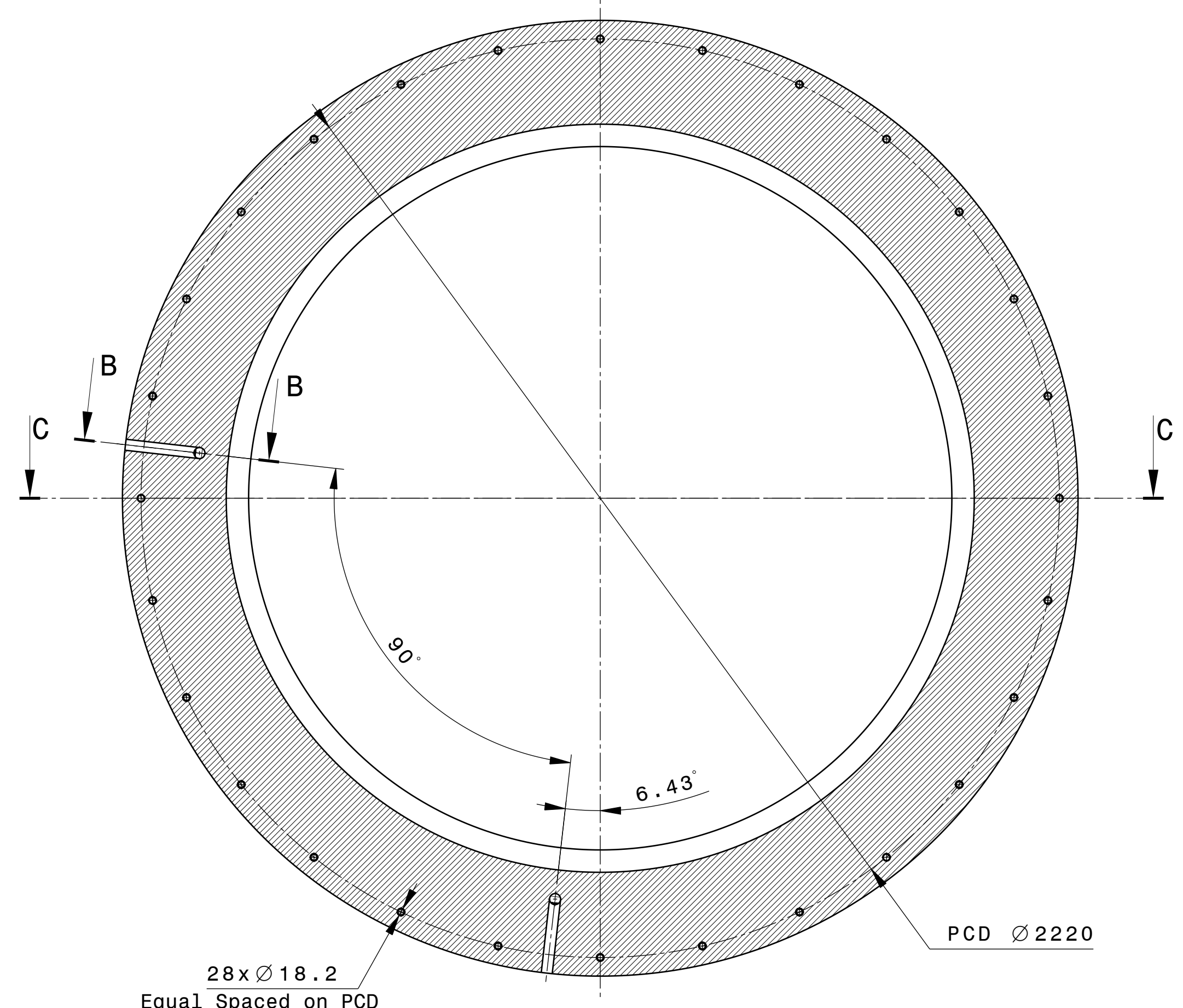

Section view A-A  
Scale: 1:10

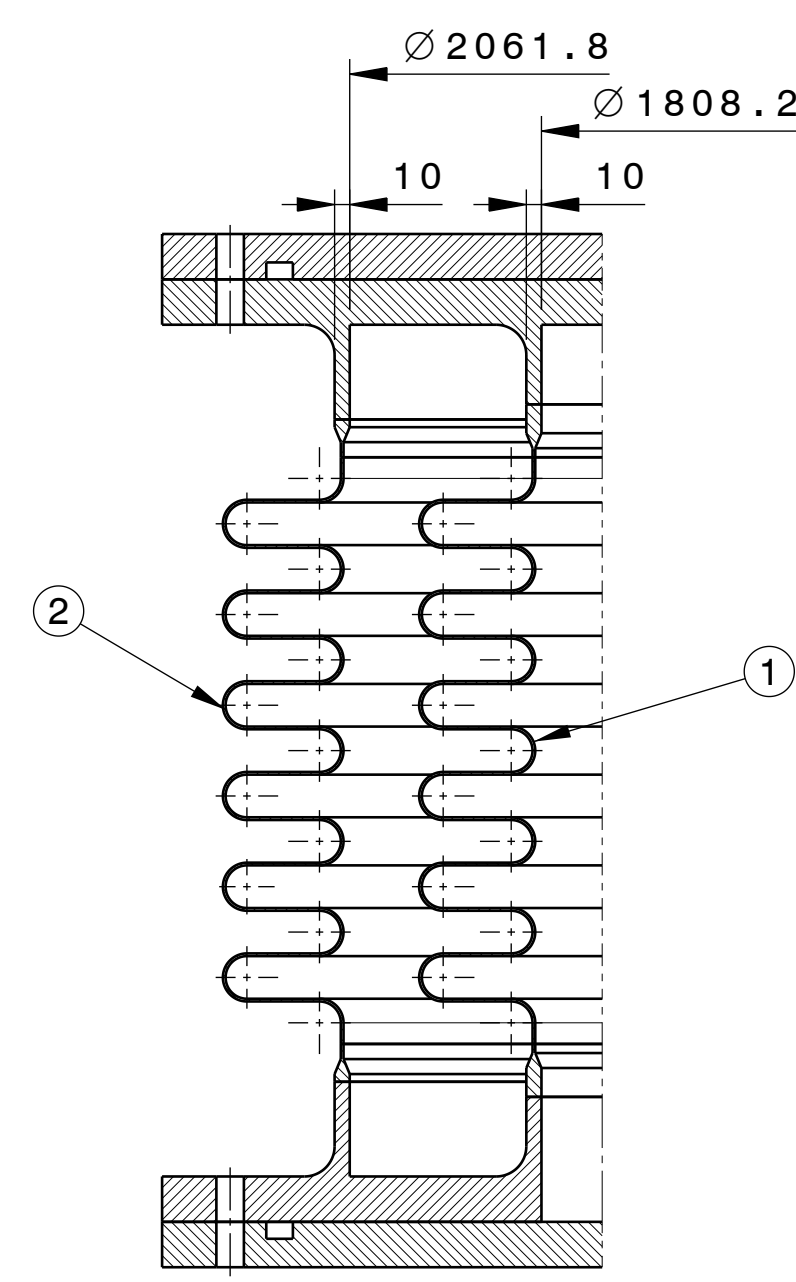

Detail D  
Scale: 1:5

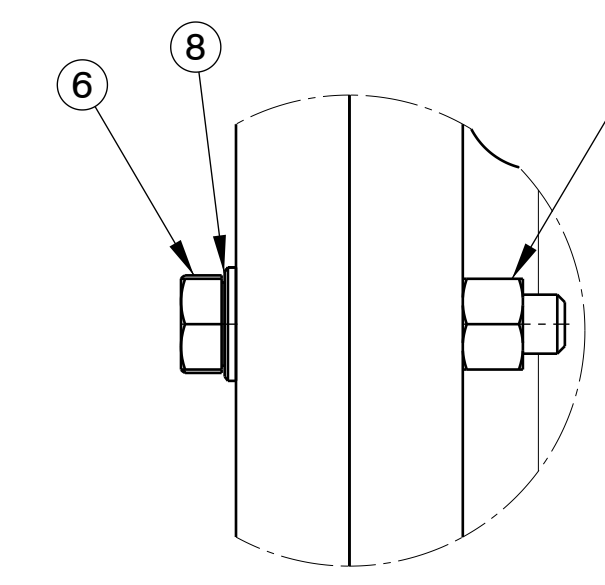

Detail I  
Scale: 1:2

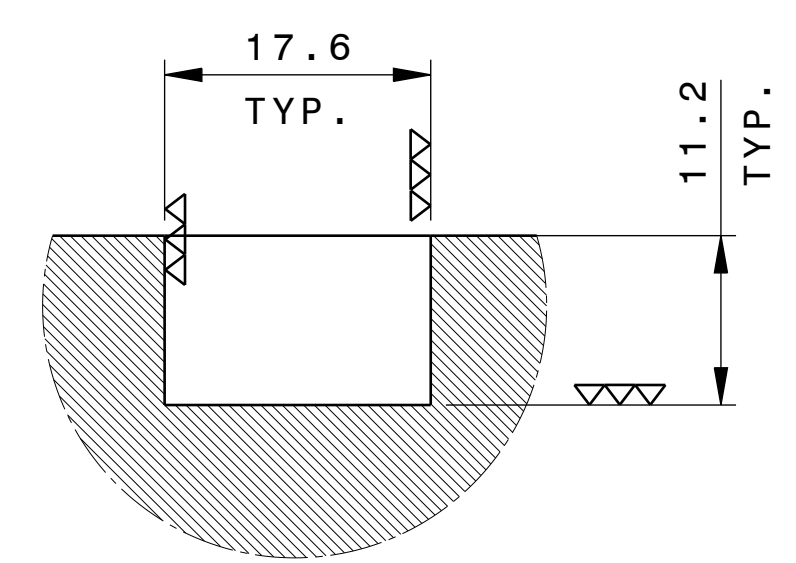

Detail J  
Scale: 2:1

GENERAL TOLERANCE:  
 MACHINED PARTS: ISO 2768-mK  
 WELDED CONSTRUCTION: EN ISO 13920-BE  
 VACUUM CLASS: VQC-1A  
 SURFACE ROUGHNESS:  $\sqrt{Ra}$  6.3

NO.	DESCRIPTION	MATERIAL	QUANTITY
01	INNER BELLOW	1.4306	01
02	OUTER BELLOW	1.4306	01
03	FLANGE_01	1.4307	01
04	FLANGE_02	1.4307	01
05	BLANK FLANGE	1.4307	02
06	ISO 4016 M16x90 HEXAGONAL HEAD BOLT	1.4307	56
07	ISO 4034 M16 NUT	1.4307	56
08	ISO 7089 WASHER 16x30	1.4307	56

NOTE :-  
 1. ALL DIMENSIONS ARE IN millimeters UNLESS STATED.  
 2. DESIGN AND MANUFACTURING ACCORDING TO EN14917  
 3. ALL OTHER PARTS (EXCEPT BELLOWS) ARE MADE FROM THE MATERIAL 1.4307

DRW DOC ID	RELEASED BY	IPR	CONFIDENTIAL UNLESS AUTHORIZED The information on this drawing is confidential under the terms of the ITER-India agreement. This information shall not be transmitted to anyone who is not authorized to receive it.	
LINED EVS PT ID	APPROVED BY	AKC-DNB		
DRW TITLE	CHECKED BY	JJ-DNB	DRAWING TITLE	
REV DATE	PT FACILITY	PT VERSION	DOUBLE WALL SINGLE EXPANSION JOINT (EJ-2)	
DD MTH YR	AA	N		
SHEET FORMAT	SCALE	PT STATUS		
A1	1:1	S		
THIRD ANGLE PROJECTION	NO OF SHEETS	NO OF PAGES	DRAWING NUMBER	REVISOR
	01	02	NN XX YY	NNN
			1001-02	Z



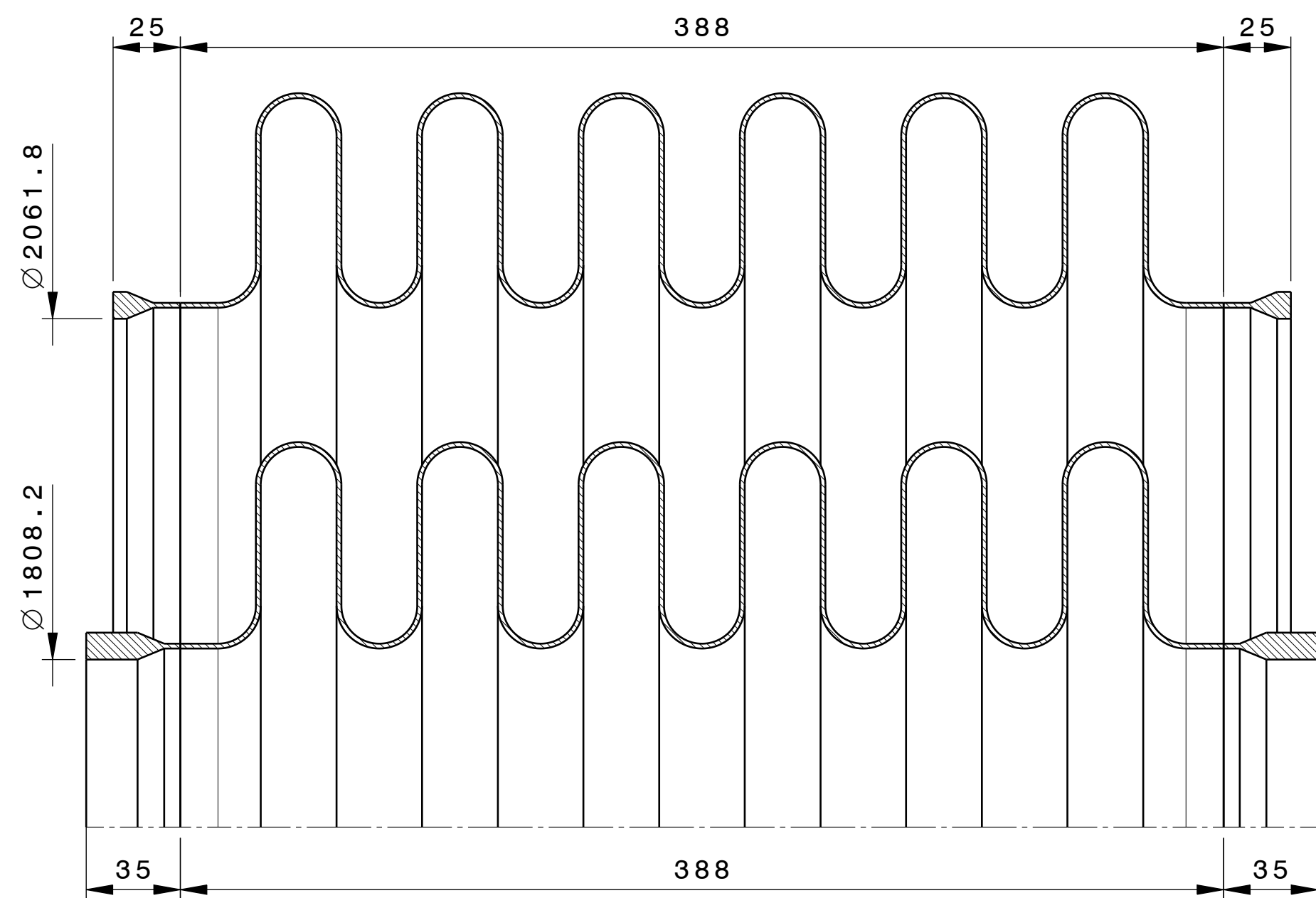

Detail B  
Scale: 1:2

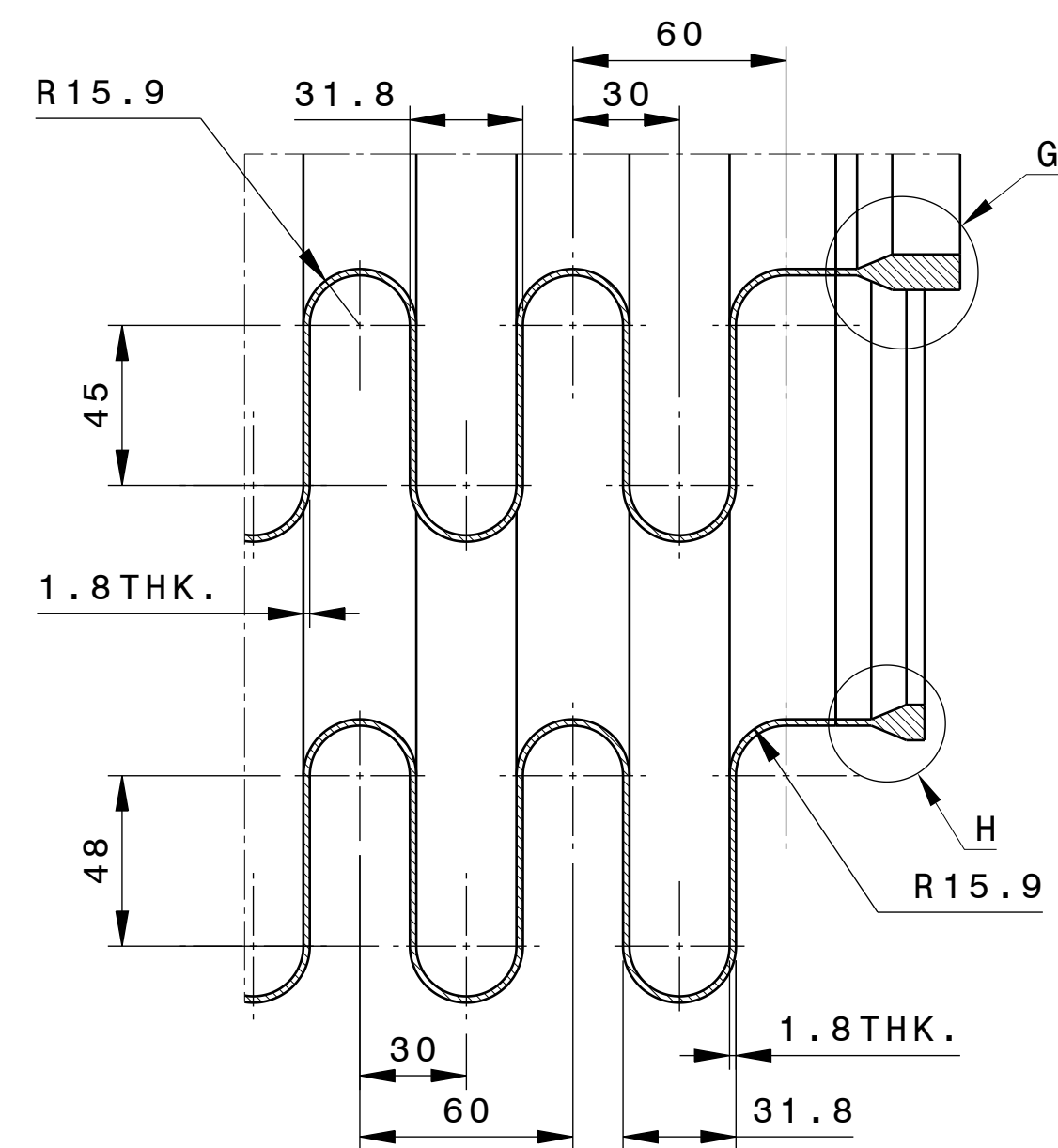

Detail F  
Scale: 1:2

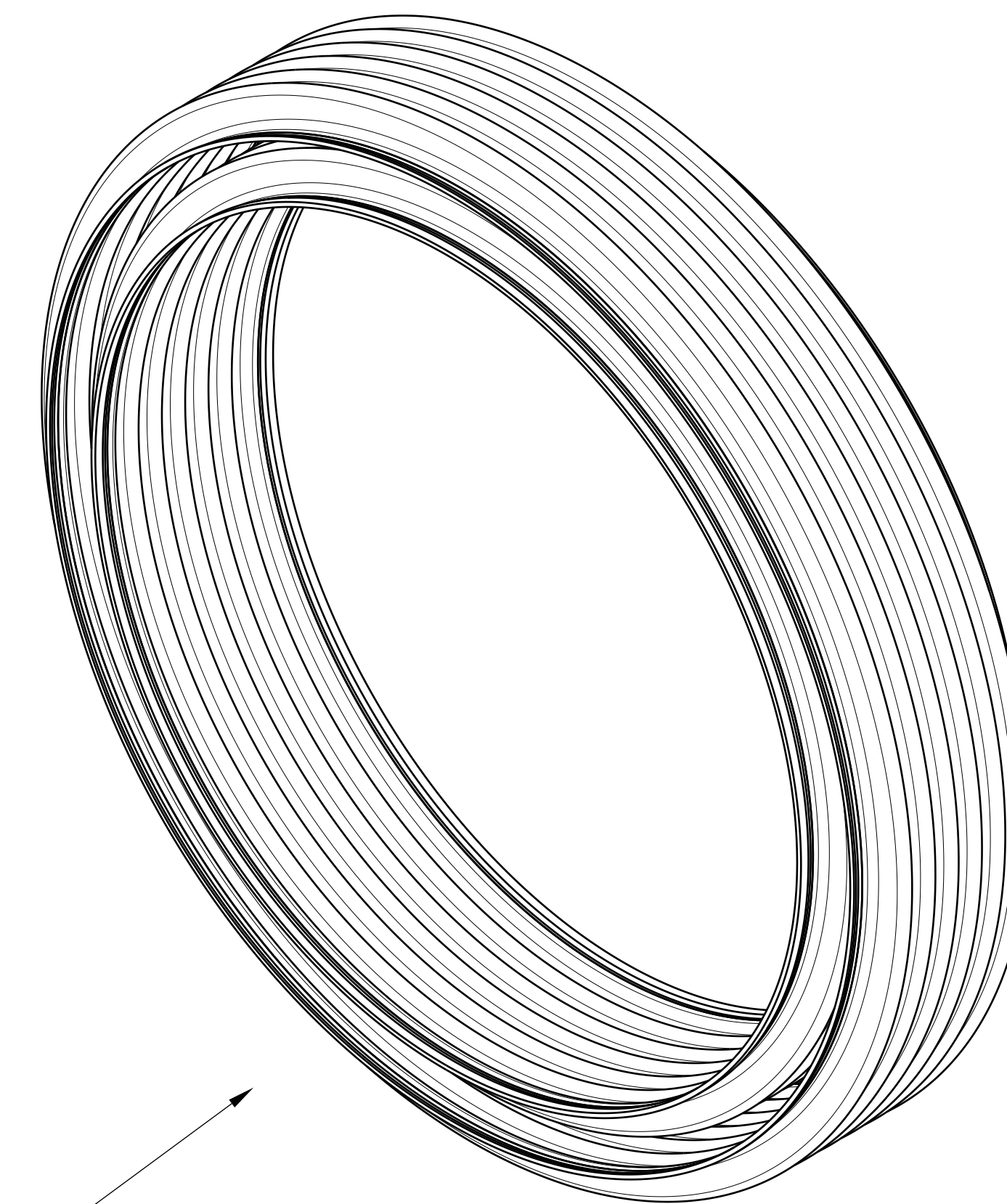

Isometric view  
Scale: 1:10

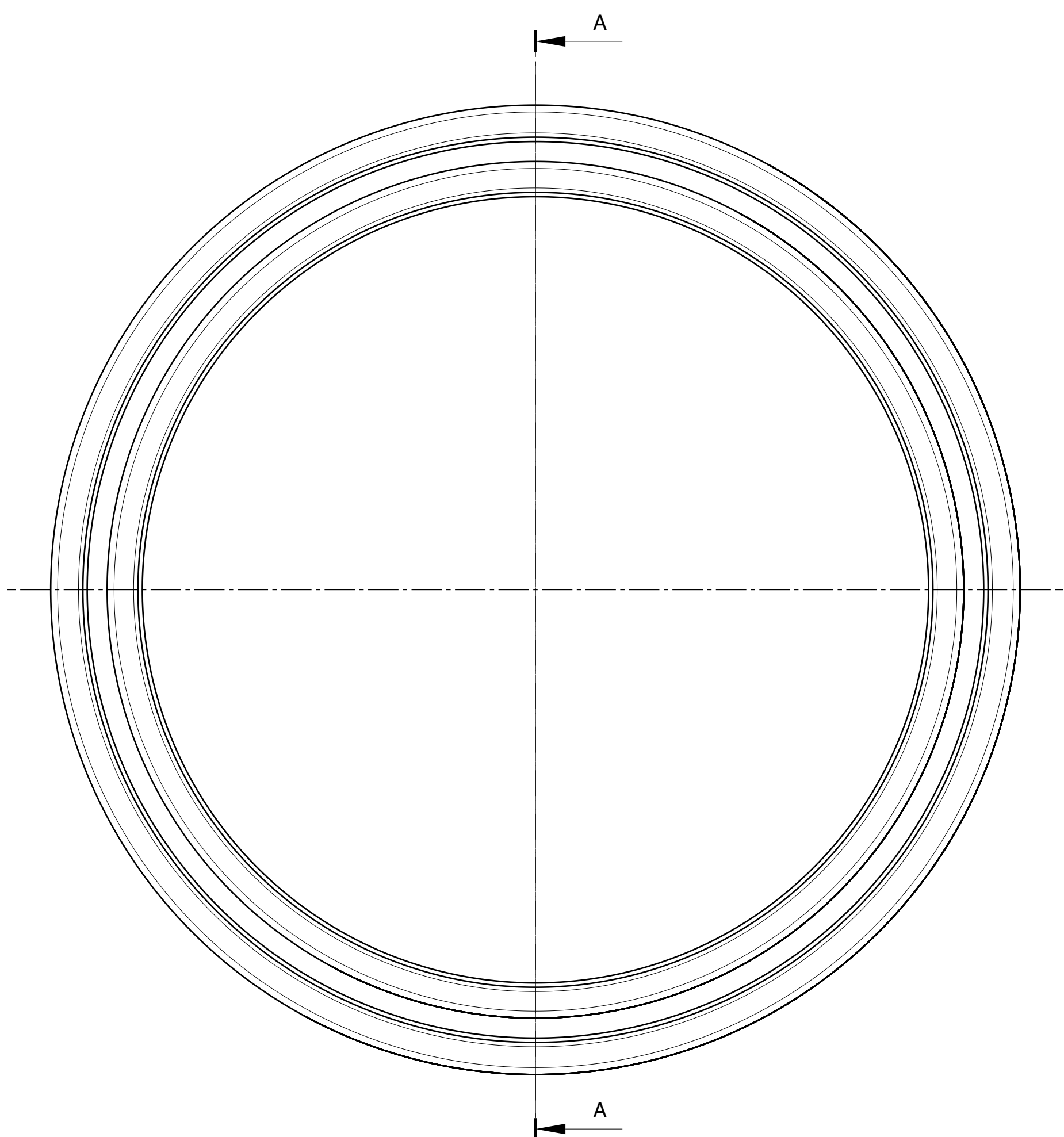

Front view  
Scale: 1:10

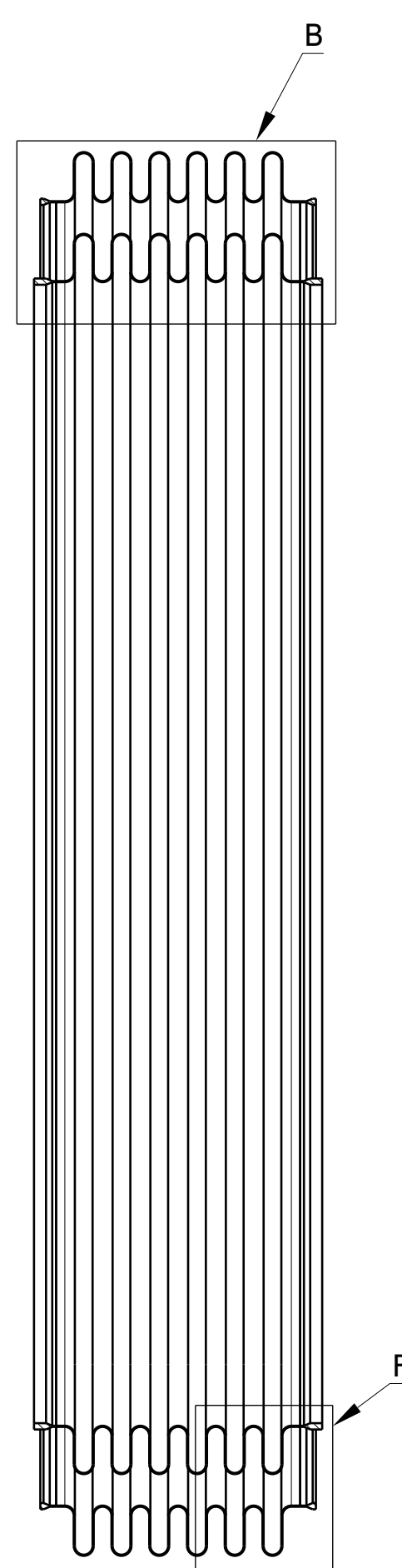

Section view A-A  
Scale: 1:10

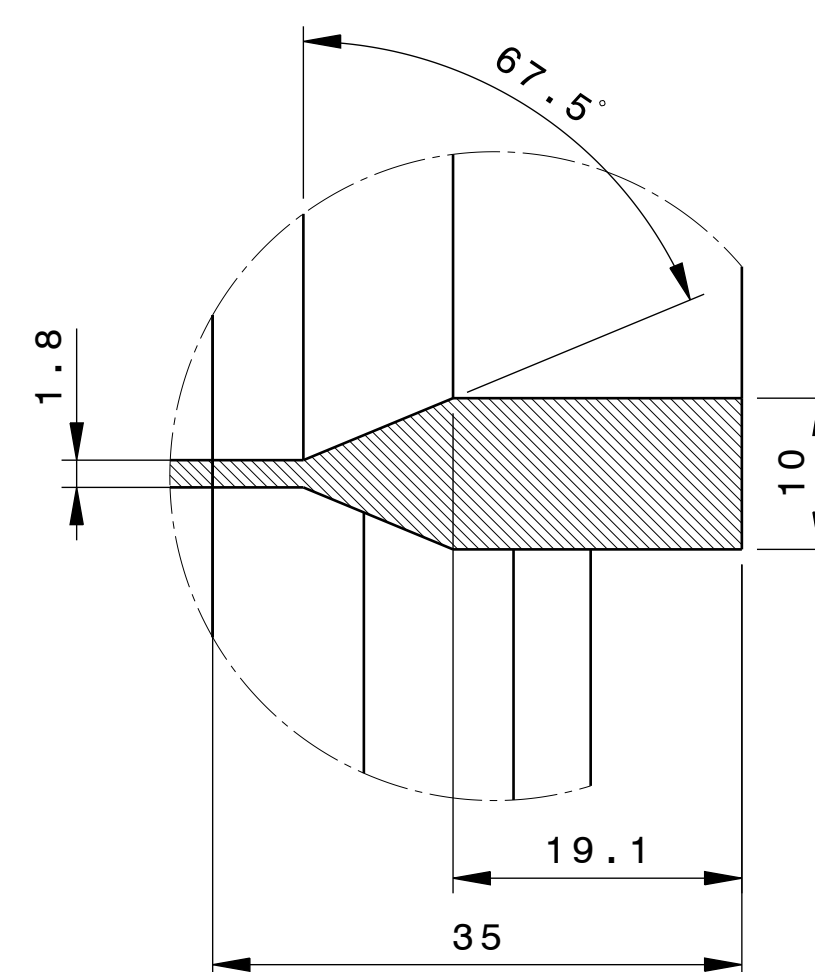

Detail G  
Scale: 2:1

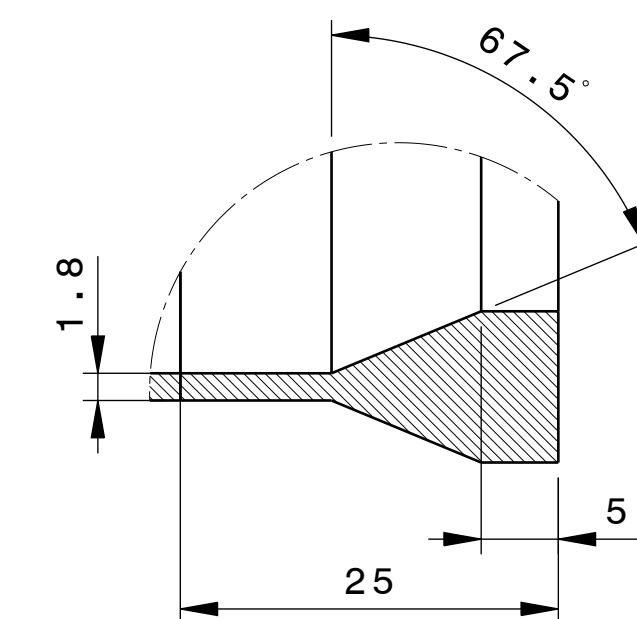

Detail H  
Scale: 2:1

GENERAL TOLERANCE:  
 MACHINED PARTS: ISO 2768-mK  
 WELDED CONSTRUCTION: EN ISO 13920-BE  
 BELLOWS/EXPANSION JOINT: EN14917  
 MATERIAL: SS304L-1.4306  
 VACUUM CLASS: VQC-1A  
 SURFACE ROUGHNESS:  $\sqrt{Ra}$  6.3

NOTE :-  
 1. ALL DIMENSIONS ARE IN millimeters UNLESS STATED.  
 2. DESIGN AND MANUFACTURING ACCORDING TO EN14917

DRW DOC ID		RELEASED BY		IPR		CONFIDENTIAL UNLESS AUTHORIZED		
LINKED EVS PT ID		APPROVED BY		AKC-DNB		The information on this drawing is confidential under the terms of the ITR-India agreement. This information shall not be transmitted to anyone who is not authorized to receive it.		
SHEET FORNIT		CHECKED BY		JJ-DNB		DRAWING TITLE		DOUBLE WALL SINGLE EXPANSION JOINT (EJ-2)
REV DATE		CONTROLLED BY		MVN-DNB				
DD MTH YR		SCALE		PT STATUS		DT		
A1		1:10		S				
THIRD ANGLE PROJECTION		NO OF SHEETS		SHEET		DRAWING NUMBER		REVISOR
		02		02		NN XX YY		NNN
						1001-02		Z



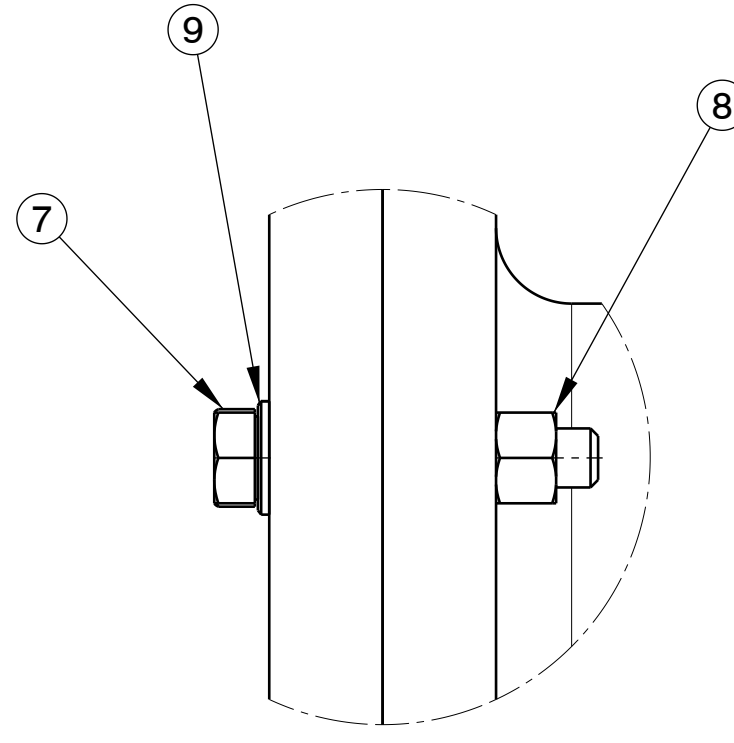

Detail G  
Scale: 1:2

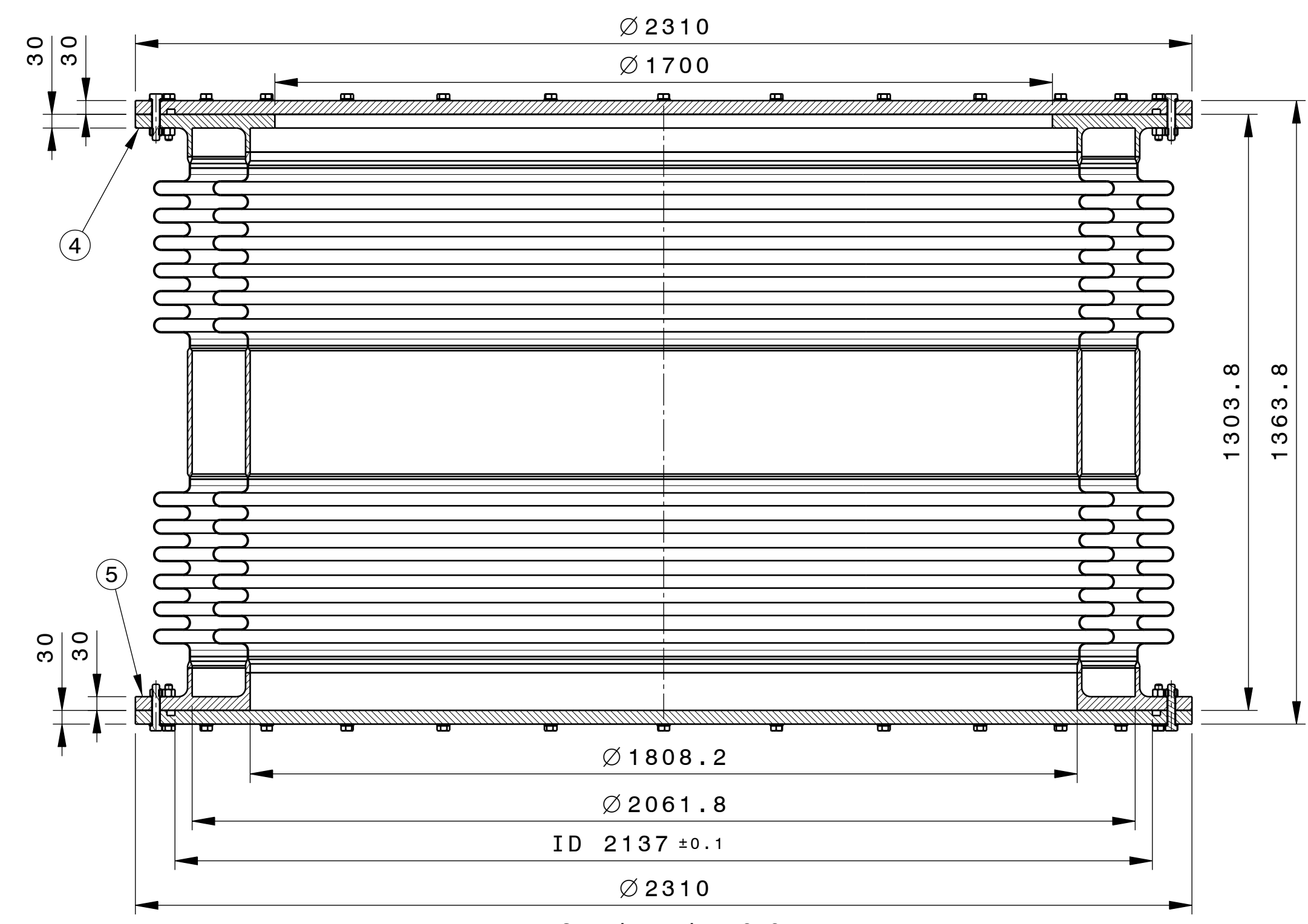

Section view C-C  
Scale: 1:10

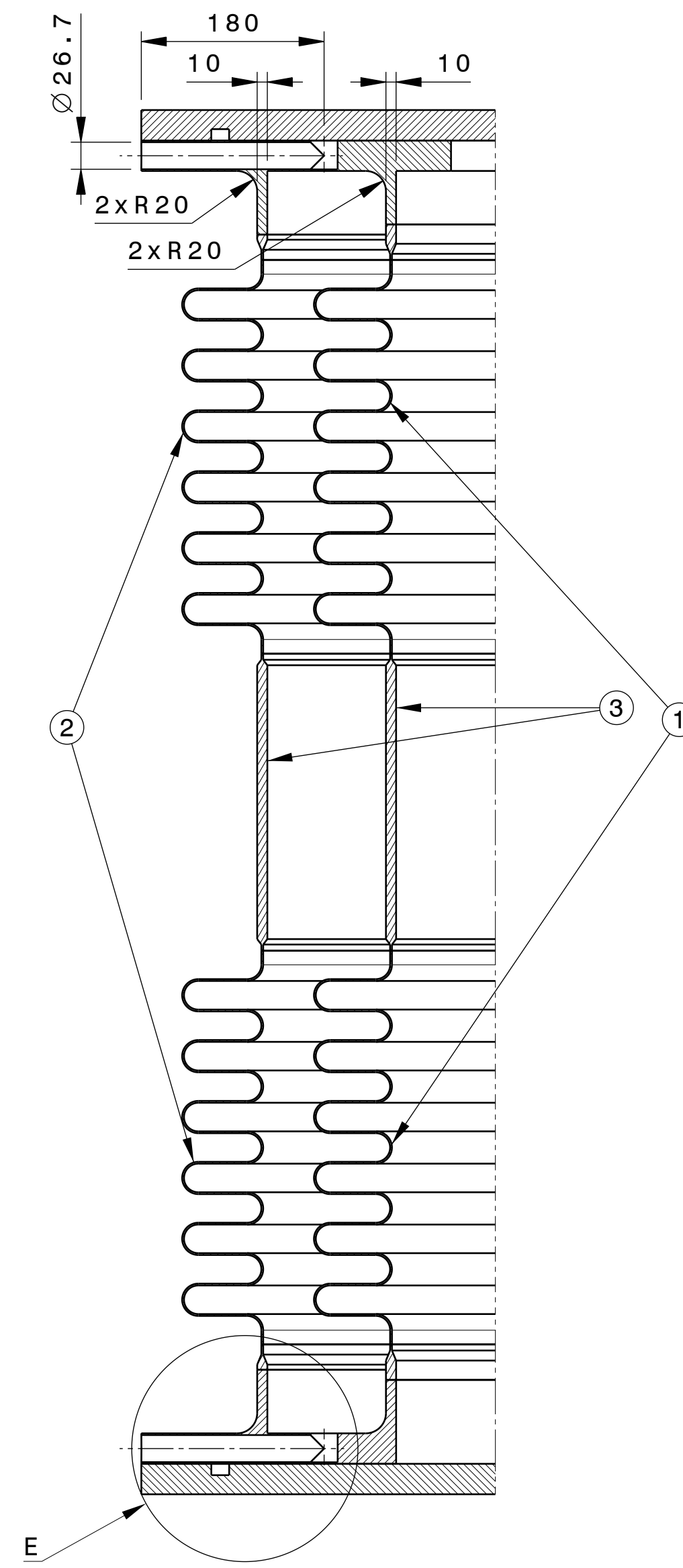

Section view B-B  
Scale: 1:5

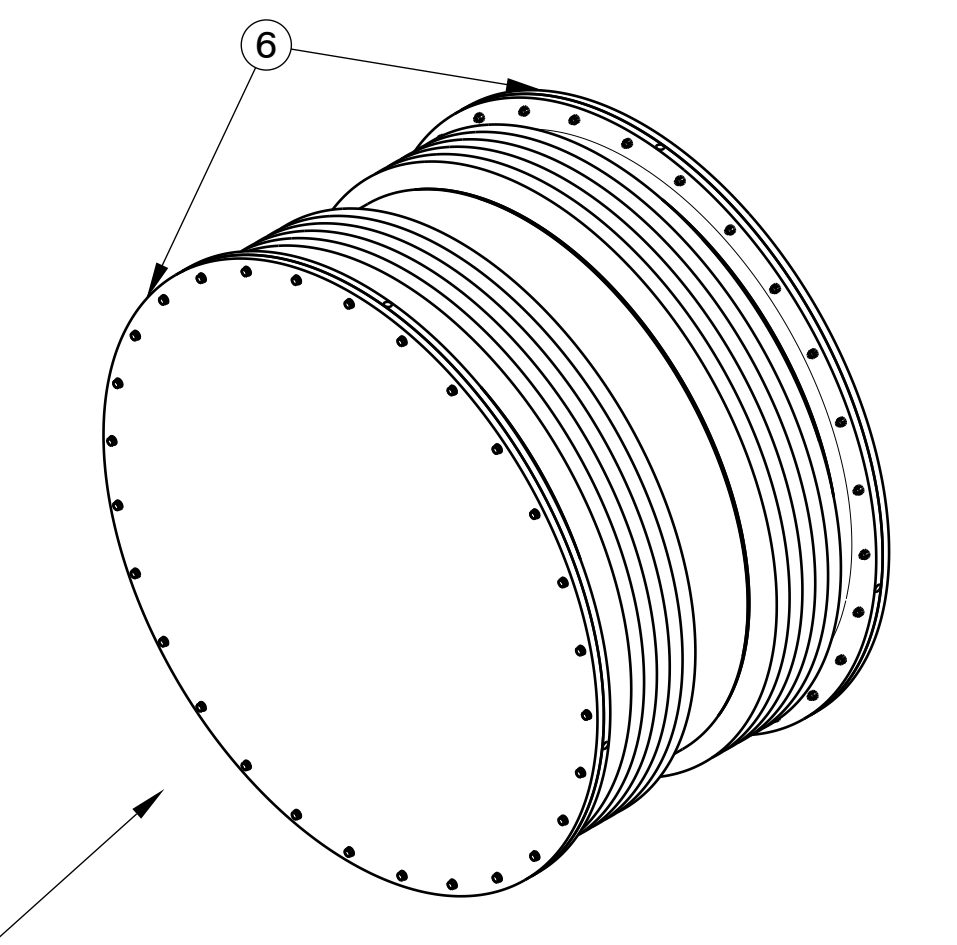

ISOMETRIC VIEW

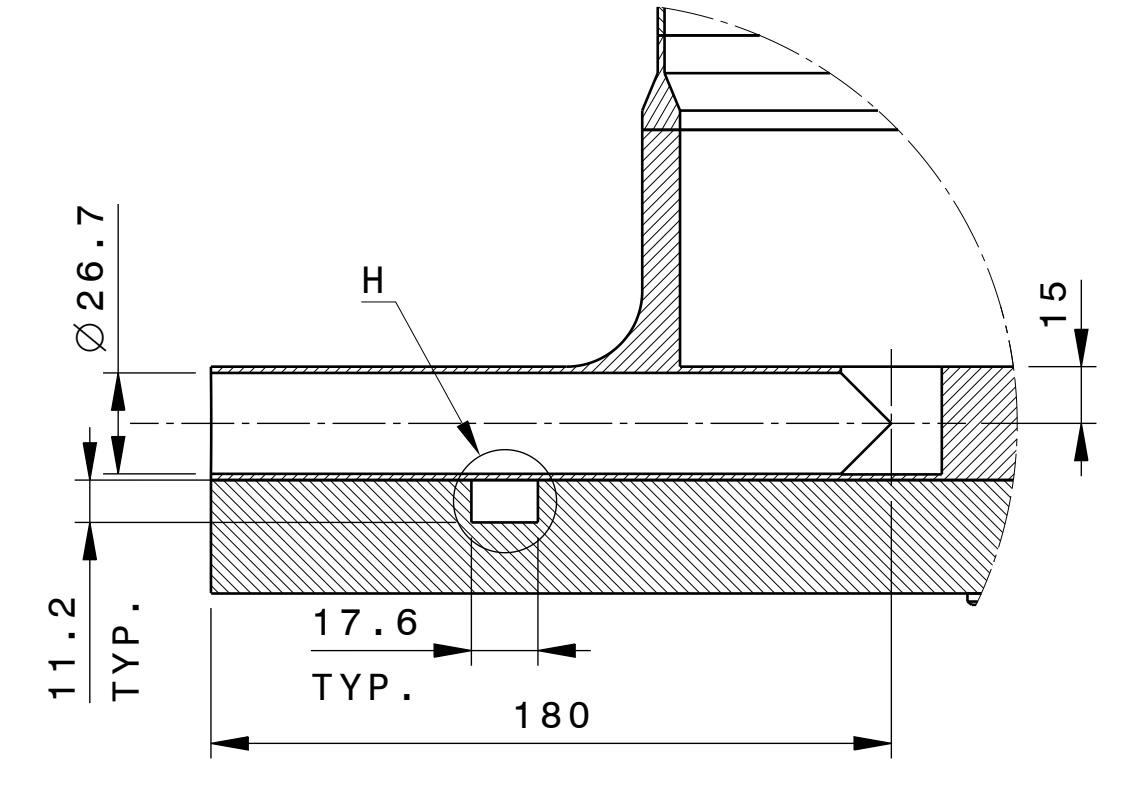

Detail E  
Scale: 1:2

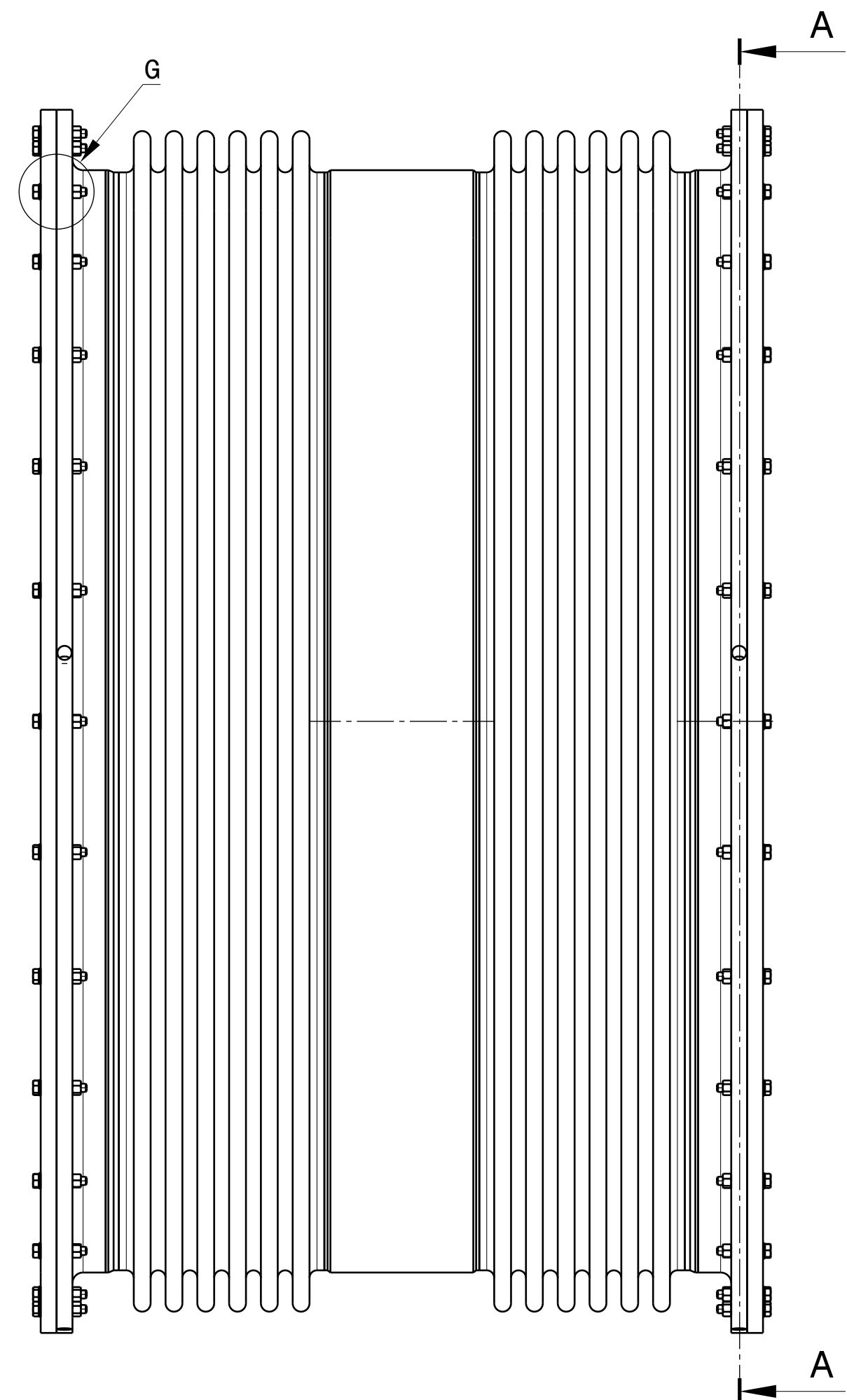

Front view  
Scale: 1:10

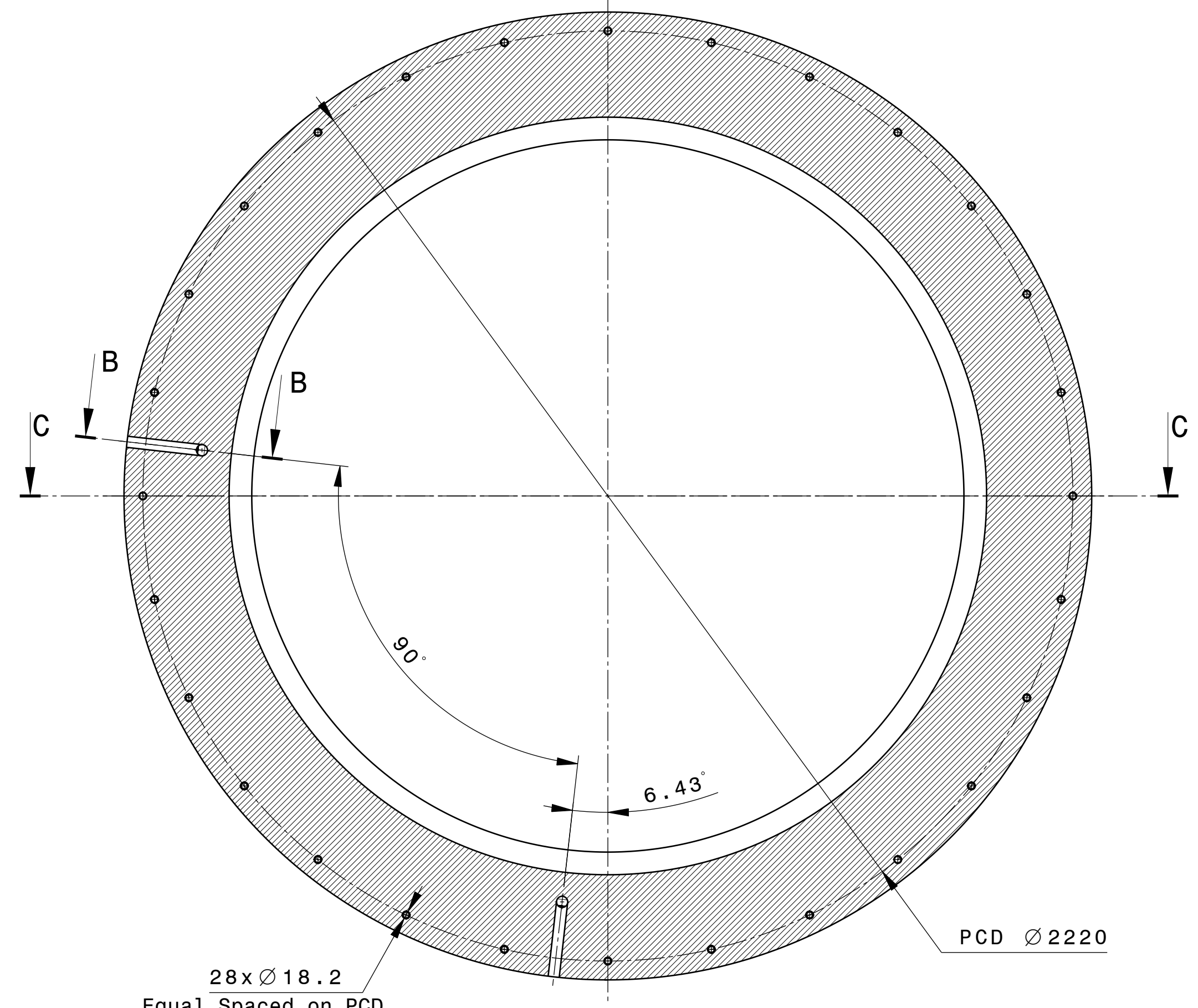

Section view A-A  
Scale: 1:10

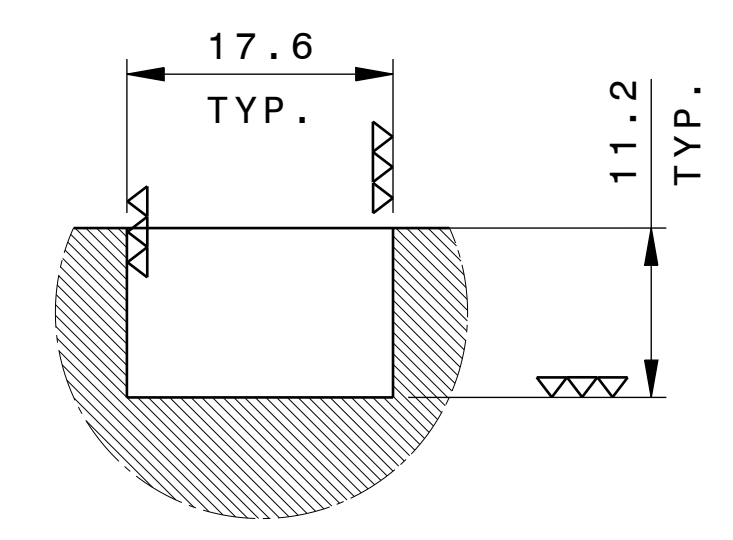

Detail H  
Scale: 2:1

GENERAL TOLERANCE:  
MACHINED PARTS: ISO 2768-mK  
WELDED CONSTRUCTION: EN ISO 13920-BE  
VACUUM CLASS: VQC-1A  
SURFACE ROUGHNESS:  $\sqrt{Ra}$  6.3

NO.	DESCRIPTION	MATERIAL	QUANTITY
01	INNER BELLOW	1.4306	01
02	OUTER BELLOW	1.4306	01
03	SPACER	1.4307	02
04	FLANGE_01	1.4307	01
05	FLANGE_02	1.4307	01
06	BLANK FLANGE	1.4307	02
07	ISO_4016_M16x90 HEXAGONAL HEAD BOLT	1.4307	56
08	ISO 4034 M16 NUT	1.4307	56
09	ISO 7089 WASHER 16x30	1.4307	56

NOTE :-  
1. ALL DIMENSIONS ARE IN millimeters UNLESS STATED.  
2. DESIGN AND MANUFACTURING ACCORDING TO EN14917  
3. ALL OTHER PARTS (EXCEPT BELLOWS) ARE MADE FROM THE MATERIAL 1.4307

DRW DOC ID		RELEASED BY		CONFIDENTIAL UNLESS AUTHORIZED The information on this drawing is confidential under the terms of the ITER-India agreement. This information shall not be transmitted to anyone who is not authorized to receive it.	
LINKED EVS PT ID		IPR			
PBS TITLE		AKC-DNB			
REV DATE		CONTROLLED BY		DRAWING TITLE	
DD MTH YR	AA	PT VERSION	MVN-DNB	DOUBLE WALL UNIVERSAL EXPANSION JOINT (EJ-3)	
SHEET FORMAT	SCALE	PT STATUS	DT		
A1	1:1	S	DT		
THIRD ANGLE PROJECTION	01	NO OF SHEETS	02	DRAWING NUMBER	1001-02
		PBS 3 LEVELS	NN XX YY	REVISOR	NNN
				DR STATUS	Z



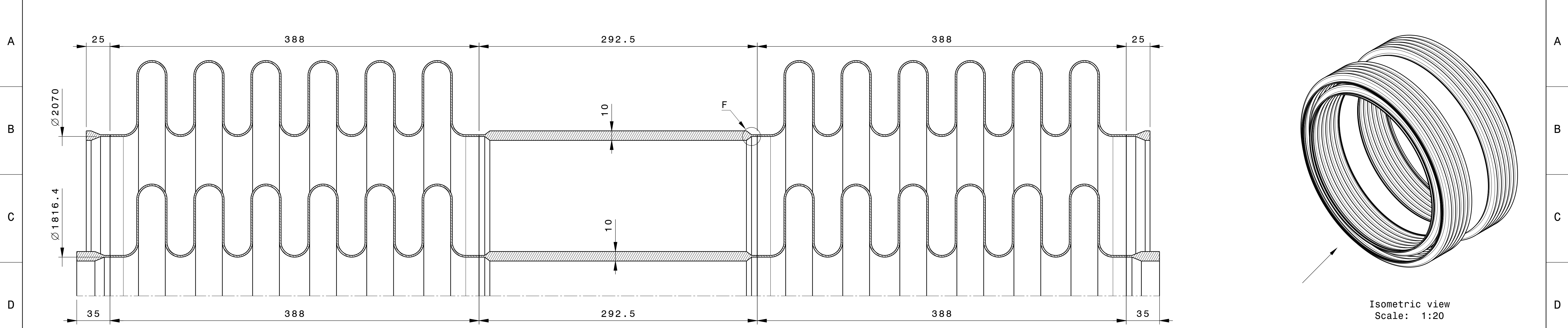

Detail B  
Scale: 1:2

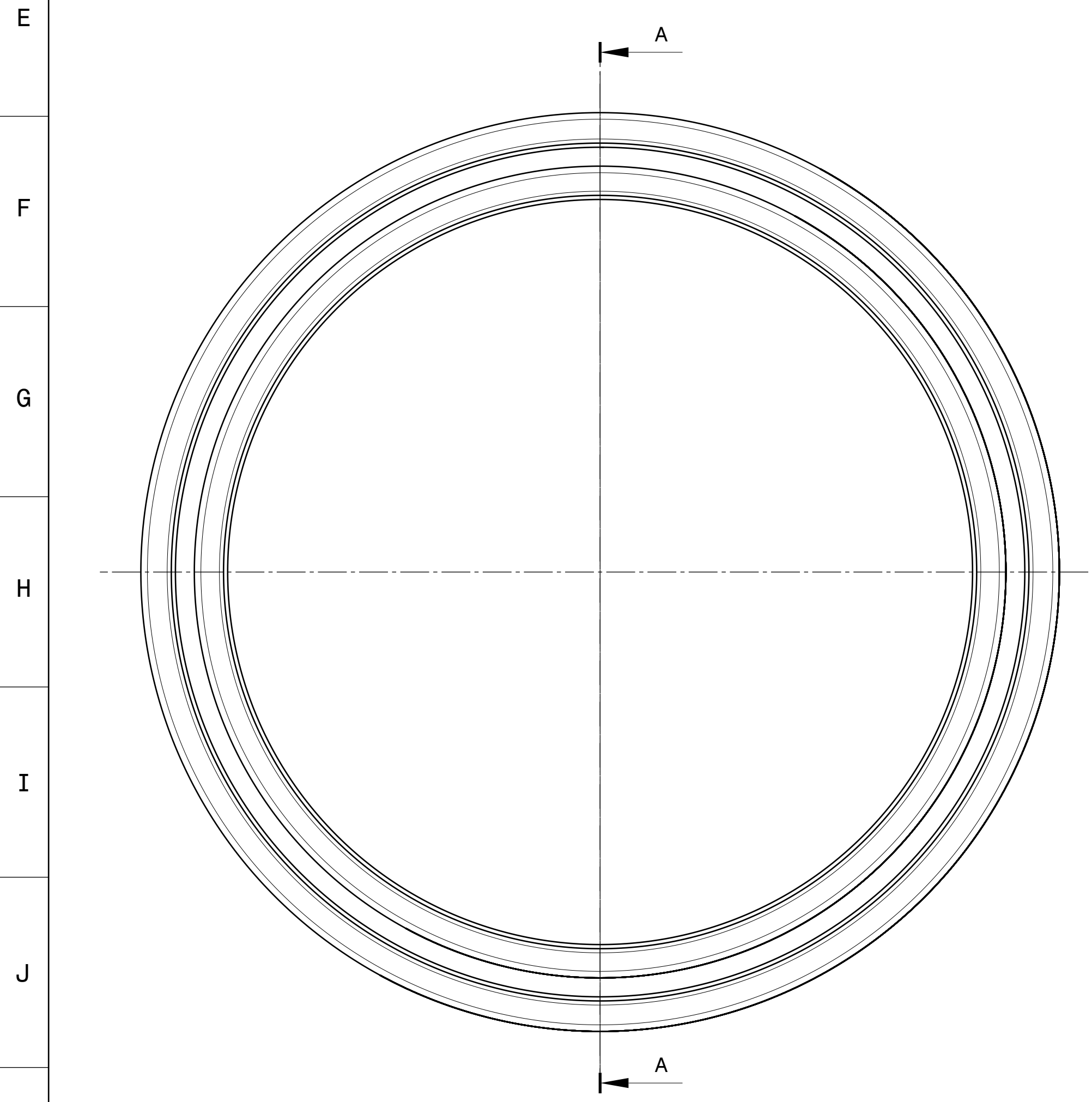

Front view  
Scale: 1:10

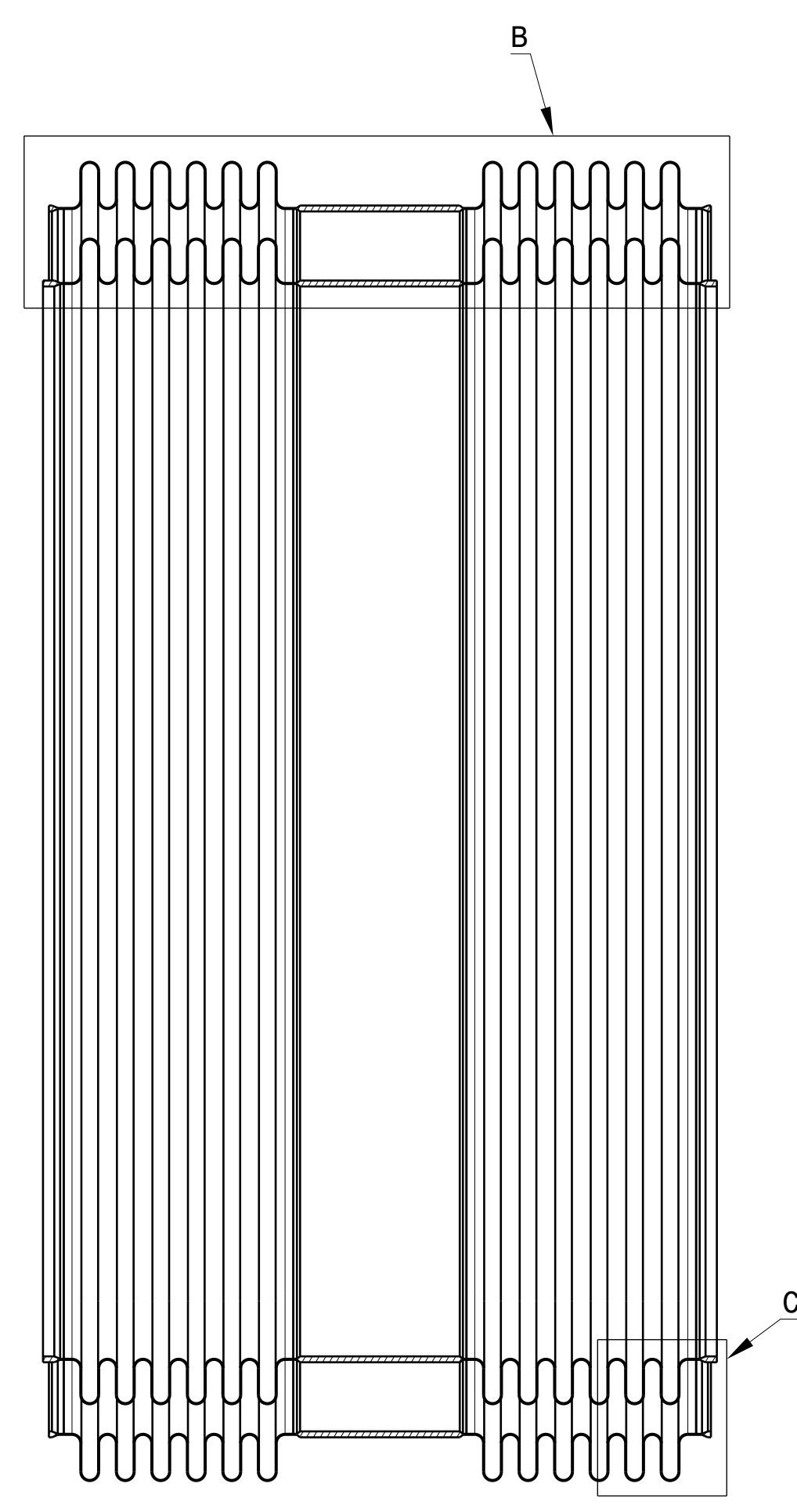

Section view A-A  
Scale: 1:10

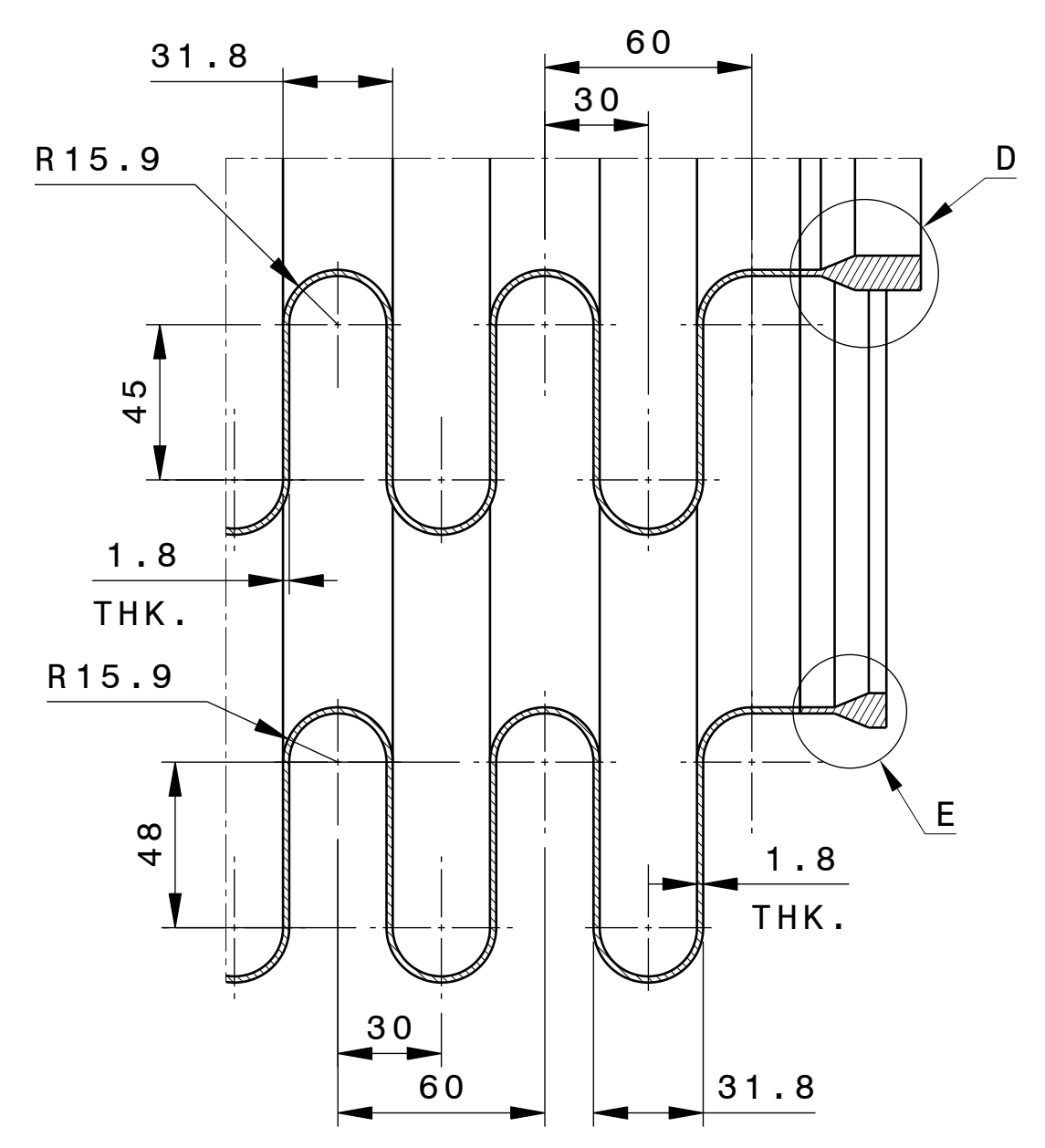

Detail C  
Scale: 1:2

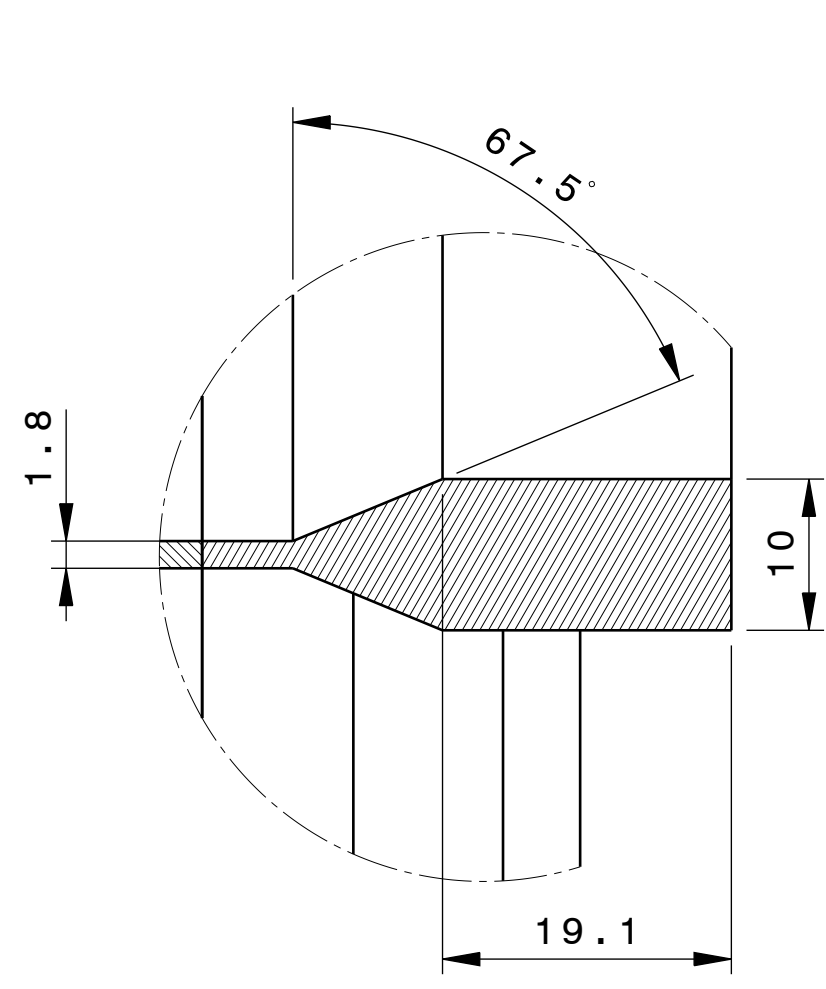

Detail D  
Scale: 2:1

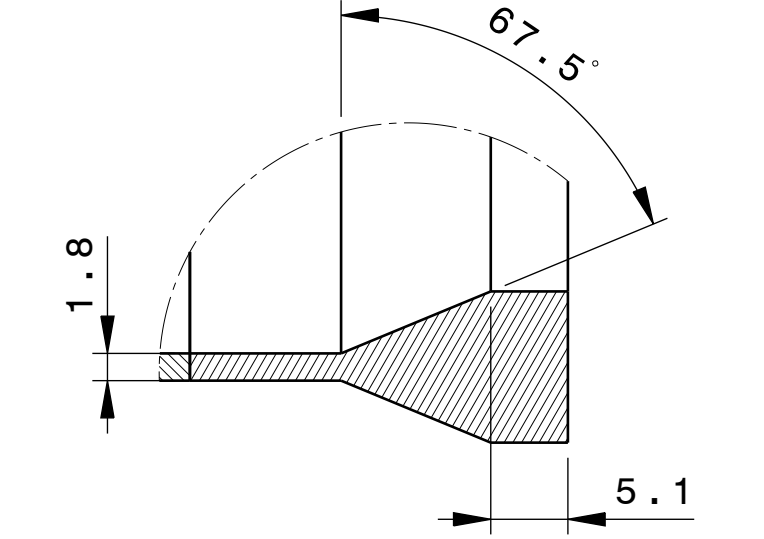

Detail E  
Scale: 2:1

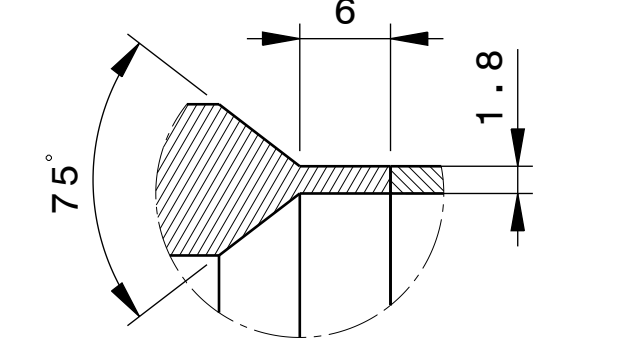

Detail F  
Scale: 2:1

GENERAL TOLERANCE:  
 MACHINED PARTS: ISO 2768-mK  
 WELDED CONSTRUCTION: EN ISO 13920-BE  
 BELLWS/EXPANSION JOINT: EN14917  
 MATERIAL: SS304L-1.4306  
 VACUUM CLASS: VQC-1A  
 SURFACE ROUGHNESS:  $\sqrt{Ra}$  6.3

DRW DOC ID		RELEASED BY		CONFIDENTIAL UNLESS AUTHORIZED The information on this drawing is confidential under the terms of the ITR-India agreement. This information shall not be transmitted to anyone who is not authorized to receive it.	
LINKED EVS PT ID		IPR			
PDS TITLE		AKC-DNB			
REV DATE		CHECKED BY		DRAWING TITLE	
DD MTH YR		JJ-DNB		DOUBLE WALL UNIVERSAL EXPANSION JOINT (EJ-3)	
SHEET FORMAT		CONTROLLED BY		NO OF SHEETS	
A1		MVN-DNB		02	
SCALE		PT VERSION		PDS 3 LEVELS	
1:10		N		02 NN XX YY	
PT STATUS		DRAWN BY		DRAWING NUMBER	
S		DT		1001-02	
THIRD ANGLE PROJECTION		NO OF SHEETS		REVISOR	
02		02		NNN	
02		02		Z	

NOTE :-  
 1. ALL DIMENSIONS ARE IN millimeters UNLESS STATED.  
 2. DESIGN AND MANUFACTURING ACCORDING TO EN14917

**SECTION 'D'**  
**FORMAT FOR SUBMISSION**  
**OF PART-II**  
**(PRICE)**



[Validate](#)[Print](#)[Help](#)

## Item Rate BoQ

Tender Inviting Authority: Head-Purchase Section

Name of Work: Design, Manufacturing, Inspection, Testing, FAT, Supply and SAT of Double walled bellows at Institute for Plasma Research, Gandhinagar as per the detailed specifications mentioned in the tender documents.

Tender No: IPR/TN/PUR/TPT/ET/21-22/036 dated 30/12/2021

<b>PRICE SCHEDULE</b>						
<b>(This BOQ template must not be modified/replaced by the bidder and the same should be uploaded after filling the relevant columns, else the bidder is liable to be rejected for this tender. Bidders are allowed to enter the Bidder Name and Values only )</b>						
NUMBER #	TEXT #	NUMBER #	TEXT #	NUMBER #	NUMBER #	TEXT #
Sl. No.	Item Description	Quantity	Units	BASIC RATE In Figures To be entered by the Bidder in Rs. P	TOTAL AMOUNT Without Taxes in Rs. P	TOTAL AMOUNT In Words
1	2	4	5	13	53	55
1	Design, Manufacturing, inspection, Testing (except covered under sr. no.6 below) & Supply of expansion joint covered under Deliverable A as per the detailed specifications mentioned in the tender documents.	1.000	Set		0.00	INR Zero Only
2	Design, Manufacturing, inspection, Testing (except covered under sr. no.6 below) & Supply of expansion joint covered under Deliverable B as per the detailed specifications mentioned in the tender documents.	1.000	Set		0.00	INR Zero Only
3	Design, Manufacturing, inspection, Testing (except covered under sr. no.6 below) & Supply of expansion joint covered under Deliverable C as per the detailed specifications mentioned in the tender documents.	1.000	Set		0.00	INR Zero Only

4	Design, Manufacturing, inspection, Testing (except covered under sr. no.6 below) & Supply of expansion joint covered under Deliverable D as per the detailed specifications mentioned in the tender documents.	1.000	Set		0.00	INR Zero Only
5	Design, Manufacturing, inspection, Testing (except covered under sr. no.6 below) & Supply of expansion joint covered under Deliverable E as per the detailed specifications mentioned in the tender documents.	1.000	Set		0.00	INR Zero Only
6	Site Acceptance testing of sr. no.1 to 5 of above as per the detailed specifications mentioned in the tender documents.	1.000	Service		0.00	INR Zero Only
<b>Total in Figures</b>					<b>0.00</b>	INR Zero Only
<b>Quoted Rate in Words</b>	<b>INR Zero Only</b>					