

This file has been cleaned of potential threats.

To view the reconstructed contents, please SCROLL DOWN to next page.



प्लाज्मा अनुसंधान संस्थान
INSTITUTE FOR PLASMA RESEARCH
परमाणु ऊर्जा विभाग, भारत सरकार का एक सहायता प्राप्त
संस्थान



An Aided Institute of Department of Atomic Energy,
Government of India

इन्दिरा पुल के पास, भट, गांधीनगर - 382 428 भारत
दूरभाष: (079) 2396 2020/2021/2028
फैक्स: 91-079-23962277
वेब: www.ipr.res.in

NEAR INDIRA BRIDGE, BHAT
DIST. GANDHINAGAR - 382 428 (INDIA)
Phone: (079) 2396 2020/2021/2028
Fax : 91-079-23962277
Web : www.ipr.res.in

ENQUIRY

ENQUIRY NO : IPR/EQL/18-19/352
Date : 09-01-2019

Due on : 07-02-2019 by 1:00 PM IST

Please send your offer in sealed envelope specifying Enquiry No, Date & Due Date, ALONG WITH your credentials for the following items:

Important Note:

Please note that e-mail quotations are not acceptable however you may send your queries (if any) to localpurchase@ipr.res.in

Please ensure your sealed quotation reaches this office not later than above mentioned due date and time.

Kindly go through the following documents properly before quoting which are available on the IPR web portal i.e., http://www.ipr.res.in/documents/tender_terms.html / attached herewith.

- 1) Instructions to the bidders & Terms and conditions (refer Form No: **IPR-LP-01.V4**)
- 2) Bidding format

GST for Goods and Services (IGST/CGST/SGST TAX BENEFITS): Please refer **clause no: 8** of Form No: **IPR-LP-01.V4**

QUOTATION SHOULD BE ADDRESSED TO PURCHASE OFFICER ONLY

Sr No	Description	Quantity
1	Supply and installation of seminar hall chairs (training chairs) with arms and full desklet as per specifications attached.	100.0 Nos.

Note: TDS as per CGST Act: As per provisions of section No. 51 of the CGST Act 2017, TDS @2% (IGST 2% or CGST 1% and SGST 1%) will be deducted while making payment to the suppliers where total value of orders/contracts/work orders exceeds Rs. 2.5 lakhs, in the event of order in Indian Rupees. Necessary TDS Certificate will be issued to the supplier after TDS deduction.

Encl: As per attachment.

Sd/-

Mr. D. Ramesh
Purchase Officer-II

Information to Vendors: We are working towards a single platform for our future

requirement. Hence, please refer IPR website i.e,
<http://www.ipr.res.in/documents/tenderseng.html> for our future requirement.

✓ ✓

Technical specification for Supply & Installation of Seminar Hall Chairs
Total quantity – 100 nos.

Providing & supplying seminar hall chairs (training chairs) with Arms and Full Desklet. Overall Size - 665W x 840D x 890H mm and 475mm seat height in loaded condition. Product should be certified from Indian Design Mark, GreenPro & Indoor Air Quality. Indoor Air Quality Certified to SCS-EC10.3-2014 v4.0 Conforms to the ANSI/BIFMA Furniture Emissions Standard (M7.1/X7.1-2011 R2016) and ANSI/BIFMA e.3-2014e (Credits 7.6.1, 7.6.2, 7.6.3) for seating parameters¹. Also, conforms to the CDPH/EHLB Standard method (CA 01350) v1.2-2017 for seating¹. OEM should be ISO 9001:2015, ISO 14001:2015, OHSAS 18001:2007, ISO 50001:2011 & BIFMA certified company.

SEAT/BACK: The seat sub-assembly is made up of 1.2 ±0.1cm thick Plywood, upholstered with moulded foam and polyester fabric (preferably in Blue colour or any suitable colour of our choice) and covered with an injection-moulded polypropylene outer cover. The seat can tip-up when not in use and this feature can be used while stacking the chairs horizontally. The back sub-assembly is made up of injection-moulded polypropylene inner upholstered with moulded foam and polyester fabric and covered with an injection-moulded polypropylene outer cover. The contoured back with width extension at the bottom area is designed to give comfort to lower back. The back flexing features allows the back to tilt by 9°±2° to aid the user in adopting a comfortable reclining posture. Both these sub-assemblies are fixed to the tubular structure.*Back Size: 45.2cm(W) X 44.6cm(H)*Seat Size:47.0cm (W) X 50.0cm (D).

TUBULAR FRAME STRUCTURE: The powder-coated 4 leg structure is made of 2.2 ±0.03cm dia x 0.25 ±0.02cm thick M.S. E.R.W. Tube front and rear leg welded along with connecting tube made of 1.9 ±0.02cm dia x 0.2 ±0.016cm thick M.S. E.R.W. Tube to form the tubular frame assembly. The legs are provided with injection-moulded adopter bush in black Nylon and Glides. Fixed glides are injection moulded in Black PP and assembled to legs.

HIGH RESILIENCE (HR) POLYURETHANE FOAM: The HR polyurethane foam is moulded with density = 70 ±8 kg/m³ and Hardness load for Seat 16 ± 2 kgf and Hardness load for back 12 ± 2 kgf as per IS:7888 for 25% compression.

ARMRESTS: The armrest structure is made up of 2.2 ±0.03cm dia x 0.25 ±0.02cm thick M.S. E.R.W. Tube welded to the Tubular Frame structure and having a scratch-resistant ABS Arm top.

FULL DESKLET: The Full Desklet assembly is Flip-up type and is made up of extension tube of 1.9 ±0.02cm dia x 0.2 ±0.016cm thick M.S. E.R.W. Tube and a support tube on L.H. side of 1.6 ±0.02cm dia x 0.2 ±0.016cm thick M.S. E.R.W. Tube on which an scratch resistant ABS desklet top is fixed and covered on bottom side with a bottom cover.

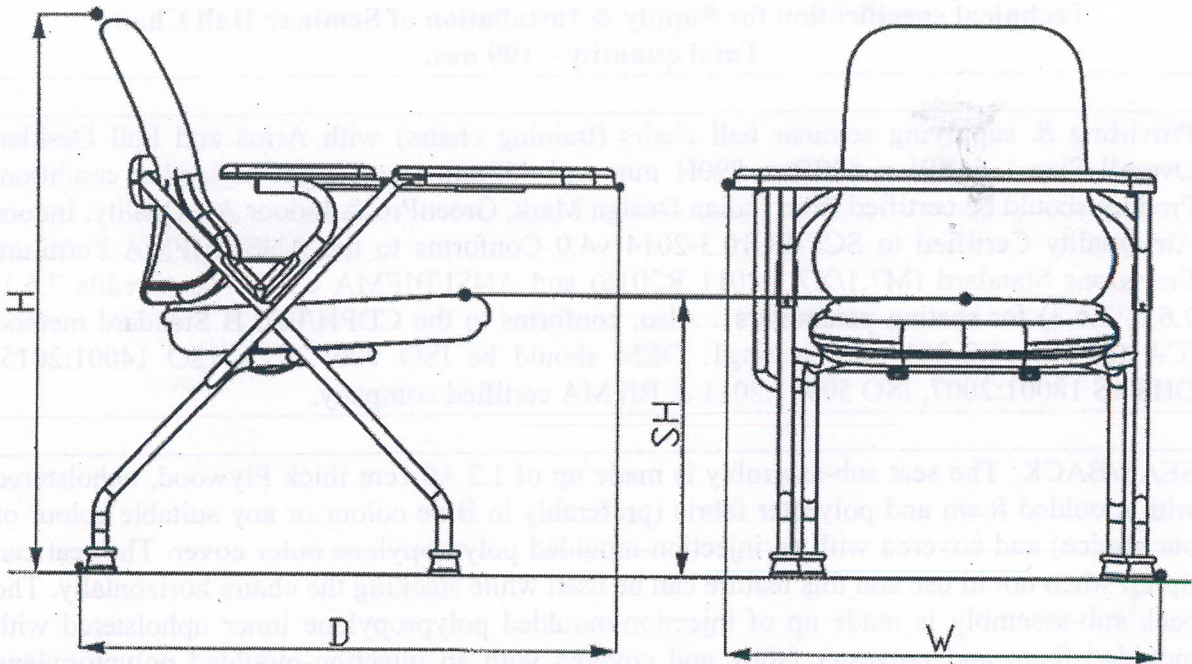

TUBULAR FRAME STRUCTURE: The tubular frame structure is made of 2.0" diameter dia x 0.22" thick M.S. E.R.W. Tube front and rear leg welded along with connection tube made of 1.9" x 0.025" dia x 0.025" thick M.S. E.R.W. Tube to form the tubular frame assembly. The legs are provided with injection molded support bush in black Nylon and Glides. Joints are injection moulded in Black TP and assembled to legs.

HIGH RESILIENCE (HR) POLYURETHANE FOAM: The HR polyurethane foam is moulded with density = 70 kg/m³ and Hardness level for Seat is 2 kg and Hardness level for back is 4.2 kg as per IS 7888 for 25% compression.

ALUMINIUM: The armrest structure is made up of 1.2" x 0.030" dia x 0.22" x 0.025" thick M.S. E.R.W. Tube welded to the tubular frame structure and having a shock resistant ABS Arm top.

FULL DESKSET: The full desk set assembly is flip-up type and is made up of extension pipe of 1.9" x 0.025" dia x 0.025" thick M.S. E.R.W. Tube and is supported on L.H. size of 1.8" x 0.025" dia x 0.025" thick M.S. E.R.W. Tube on which an injection moulded ABS desk set is fixed and supported on horizontal with 1" dia x 0.025" thick M.S. E.R.W. Tube.

✓ ✓

Note to Manufacture/Supplier:

1. The supplier shall indicate the numerical values of specifications wherever necessary and provide technical offer. **Comments like YES, AGREED, WILL BE COMPLIED, CONFIRMED are not acceptable where numerical values are required to be quoted.**
2. Installation:
Installation should be carried out by the supplier at IPR Campus in Bhat Village, Gandhinagar at free of cost.
3. Guarantee:
Furniture shall be guaranteed for a period of 12 months from the date of installation and acceptance against all design, material and manufacturing defects. Moreover, free service camp, post-warranty shall also be arranged at least for two times.
4. IPR shall be at liberty to visit the showroom and see the product(s)/sample the bidder has offered as per the quotation, before placing the purchase order.
5. The bidder should produce a product test certificate at the time of delivery of materials
6. Qualification criteria of the bidder: (who downloads the tender from website)
 - (a) Quotations from reputed Original Furniture Manufacturers (OFM) or their authorized dealers of office furniture will only be considered (they need to submit a copy of valid registration certificate for authorized dealer)
 - (b) The bidder shall be well established in the Office furniture manufacturing field or in the furniture dealership and shall have supplied similar type of furniture in the last 3-4years to reputed Institutions/Firms/Companies A list of minimum 02 Nos. of those clients with details of P.O. No. or shipping release, acceptance report, contact person's Phone No., email to whom similar furniture were supplied, shall be enclosed along with the quotation.
 - (c) **The documents viz. ISO certifications, Business Institutional Furniture Manufacturer Association (BIFMA) certificate shall be enclosed along with quotation, without such documents the quotation will not be considered.**
 - (d) The bidder should have a set up for after sales service in Ahmedabad/Gandhinagar. A self-declaration to this effect may be attached with the quotation.