

This file has been cleaned of potential threats.

To view the reconstructed contents, please SCROLL DOWN to next page.



प्लाज्मा अनुसंधान संस्थान
INSTITUTE FOR PLASMA RESEARCH
परमाणु ऊर्जा विभाग, भारत सरकार का एक सहायता प्राप्त
संस्थान
An Aided Institute of Department of Atomic Energy,
Government of India



इन्दिरा पुल के पास, भट, गांधीनगर - 382 428 भारत
दूरभाष: (079) 2396 2020/2021/2028
फैक्स: 91-079-23962277
वेब: www.ipr.res.in

NEAR INDIRA BRIDGE, BHAT
DIST. GANDHINAGAR - 382 428 (INDIA)
Phone: (079) 2396 2020/2021/2028
Fax : 91-079-23962277
Web : www.ipr.res.in

ENQUIRY

ENQUIRY NO : IPR/EQL/18-19/353
Date : 09-01-2019

Due on : 07-02-2019 by 1:00 PM IST

Please send your offer in sealed envelope specifying Enquiry No, Date & Due Date, ALONG WITH your credentials for the following items:

Important Note:

Please note that e-mail quotations are not acceptable however you may send your queries (if any) to localpurchase@ipr.res.in

Please ensure your sealed quotation reaches this office not later than above mentioned due date and time.

Kindly go through the following documents properly before quoting which are available on the IPR web portal i.e., http://www.ipr.res.in/documents/tender_terms.html / attached herewith.

- 1) Instructions to the bidders & Terms and conditions (refer Form No: IPR-LP-01.V4)
- 2) Bidding format

GST for Goods and Services (IGST/CGST/SGST TAX BENEFITS): Please refer clause no: 8 of Form No: IPR-LP-01.V4

QUOTATION SHOULD BE ADDRESSED TO PURCHASE OFFICER ONLY

Sr No	Description	Quantity
1	Supply and installation of Executive chairs (mid-back) for committee room no.1,2, VC Room and seminar hall dias as per specifications attached.	50.0 Nos.

Note: TDS as per CGST Act: As per provisions of section No. 51 of the CGST Act 2017, TDS @2% (IGST 2% or CGST 1% and SGST 1%) will be deducted while making payment to the suppliers where total value of orders/contracts/work orders exceeds Rs. 2.5 lakhs, in the event of order in Indian Rupees. Necessary TDS Certificate will be issued to the supplier after TDS deduction.

Encl: As per attachment.

Sd/-

Mr. D. Ramesh
Purchase Officer-II

Information to Vendors: We are working towards a single platform for our future

requirement. Hence, please refer IPR website i.e,
<http://www.ipr.res.in/documents/tenderseng.html> for our future requirement.

✓ ✓

Technical specification for supply & installation of Executive Chairs in Committee Rooms (1, 2, VC Room and Seminar Hall)

Total quantity – 50 Nos.

Upholstered with Leatherette seat made up of 12 MM +/- 1 MM thick hot pressed plywood and back in two Pieces - 12 MM Rear Back and 6 MM inner Back. Moulded polyurethane foam used in making seat with moulded density 45 +/- 2 kg/m³. Back is made out of 32 Density Block Foam covered with 14 mm thick 32 density foam sheet (Block foam).

Spine bracket made of M.S plate 8 MM Thickness connecting back with mechanism. Armrest top is soft touch polyurethane moulded of 250 to 300 density insert in chrome finish pipe having unique "BIRD BEAK" shape.

The mechanism of the chair have following features: 360° revolving type 3.5MM thick CRCA seat plate with 4MM thick CRCA channel plate synchro Mechanism, Tilt tension adjustable, Single position locking, Plastic component inside the mechanism of Grade - MI 3530 and Epoxy Powder coated 70 Microns with tested 1.2 lacs cycles as per BIFMA Standard

The chair provided with pneumatic height adjustment which have stroke of 100 mm +/- 5 mm.

The five leg base is made up of 38mm dia x 1.2mm thick tubular with 3.15 MM thick centre hub CRC fabricated chrome finish. It has to be fitted with 50 MM dia Twin wheel castor. The size of the base has to be - 660 +/- 1 MM pitch-centre-diameter. Load test as per BIFMA compliance.

The twin wheel castors have to be made of Nylon injection moulded in black colour.

Overall dimensions of Chair have to be, Width of Chair - 630 MM, Depth of chair 630 MM as measured from base below. Height of back from ground - min 950 to max 1050 MM. Seat height -min 470 MM to max 570 MM. Dimensions tolerance / variations have be within +/- 10 MM.

✓ ✓

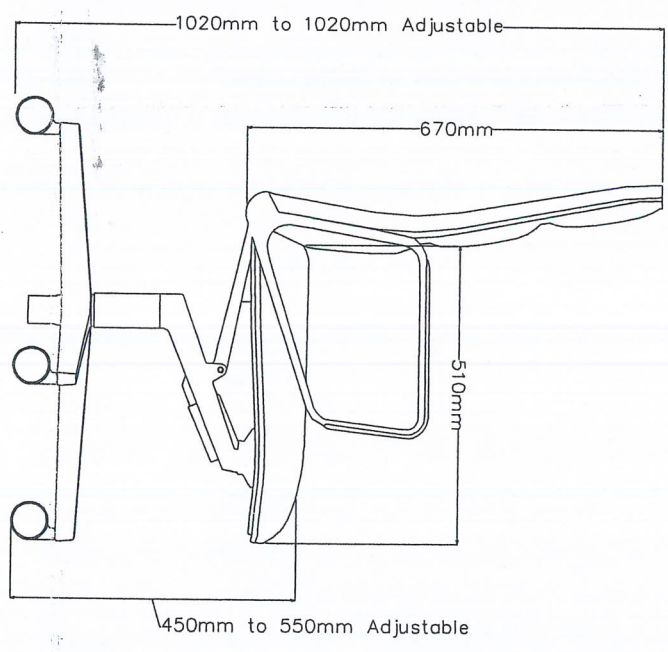
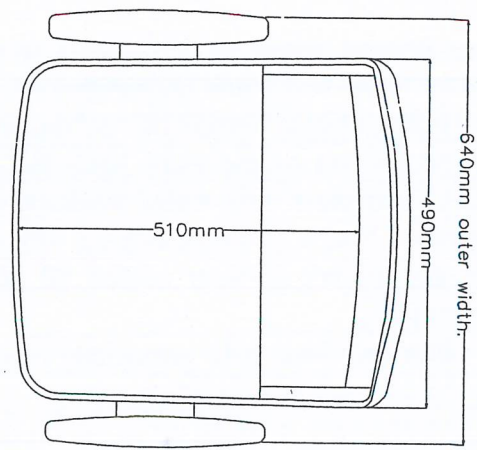
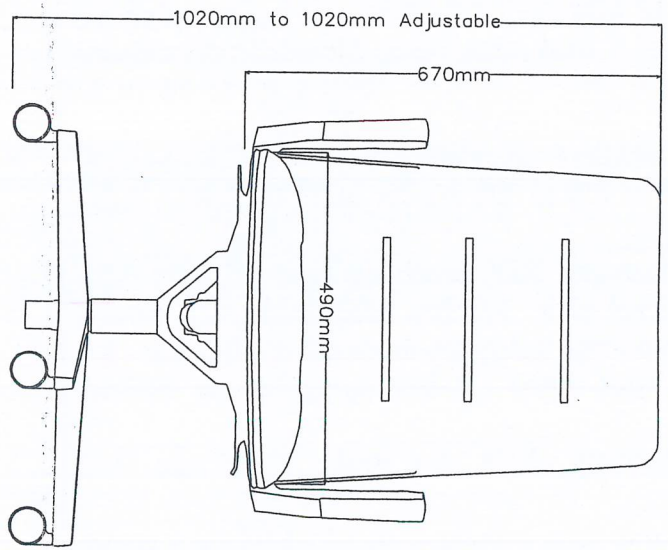

✓ ✓

Note to Manufacture/Supplier:

1. The supplier shall indicate the numerical values of specifications wherever necessary and provide technical offer. **Comments like YES, AGREED, WILL BE COMPLIED, CONFIRMED are not acceptable where numerical values are required to be quoted.**
2. Installation:
Installation should be carried out by the supplier at IPR Campus in Bhat Village, Gandhinagar at free of cost.
3. Guarantee:
Furniture shall be guaranteed for a period of 12 months from the date of installation and acceptance against all design, material and manufacturing defects. Moreover, free service camp, post-warranty shall also be arranged at least for two times.
4. IPR shall be at liberty to visit the showroom and see the product(s)/sample the bidder has offered as per the quotation, before placing the purchase order.
5. The bidder should produce a product test certificate at the time of delivery of materials
6. Qualification criteria of the bidder: (who downloads the tender from website)
 - (a) Quotations from reputed Original Furniture Manufacturers (OFM) or their authorized dealers of office furniture will only be considered (they need to submit a copy of valid registration certificate for authorized dealer)
 - (b) The bidder shall be well established in the Office furniture manufacturing field or in the furniture dealership and shall have supplied similar type of furniture in the last 3-4years to reputed Institutions/Firms/Companies A list of minimum 02 Nos. of those clients with details of P.O. No. or shipping release, acceptance report, contact person's Phone No., email to whom similar furniture were supplied, shall be enclosed along with the quotation.
 - (c) **The documents viz. ISO certifications, Business Institutional Furniture Manufacturer Association (BIFMA) certificate shall be enclosed along with quotation, without such documents the quotation will not be considered.**
 - (d) The bidder should have a set up for after sales service in Ahmedabad/Gandhinagar. A self-declaration to this effect may be attached with the quotation.