

INSTITUTE FOR PLASMA RESEARCH
NEAR INDIRA BRIDGE, BHAT, GANDHINAGAR 382 428
GUJARAT STATE
Phone: 079 23962021, 23962023 Fax: 079 23962277

TENDER NOTICE DATED 18-5-2009

Itemwise sealed tenders are invited from reputed and eligible parties for the following.

Sr. No	Tender Notice No.	Item	Quantity	Due Date & time of opening	Tender Fee (Rs.)	EMD (Rs.)
1.	IPR/TN/PUR/011/09-10	Design, layout, processing, offset printing, binding and supply of IPR Annual Report valid for 2 years from the date of placing order	As per the tender documents	19-6-2009 2.30 p.m.	200.00	5,000.00
2.	IPR/TN/PUR/012/09-10	Design, manufacturing, supply, erection and commissioning of 5 Ton Double Girder EOT Crane	1 No.	8-7-2009 2.30 p.m.	200.00	15,000.00
3.	IPR/TN/PUR/013/09-10 (TWO PART TENDER)	Design, fabrication, factory testing, installation, commissioning and testing at site of Integrated Power Supply system consisting of 18kV, 25Amp DC Supply and three auxiliary Power Supplies.	1 No.	9-7-2009 2.30 p.m.	200.00	20,000.00
4.	IPR/TN/PUR/014/09-10 (TWO PART TENDER)	Design, fabrication, factory testing, installation, commissioning and testing at site of Integrated Power Supply system consisting of 15kV, 28Amp HVDC Supply and three auxiliary Power Supplies.	1 No.	9-7-2009 3.00 p.m.	200.00	20,000.00

Tender documents are available on IPR Website : www.ipr.res.in/purchasetenders.html. Tenderers meeting the eligibility criteria mentioned in the tender documents may, at their option, download the tender documents from the website and submit their offer along with prescribed **Tender Fee (non refundable) and EMD** in the form of Demand Draft from any nationalized/scheduled bank drawn in favour of **Institute for Plasma Research** and payable at **Ahmedabad** as per the details given in the tender documents. In case party desires to collect the tender documents by post, they may contact the Purchase Officer along with prescribed tender fee. Tender documents will be issued upto **5-6-2009**. The representative who is going to attend the tender opening should carry an authorization letter from the organization for participation in the tender opening.

TENDER NOTICE No.IPR/TN/PUR/014/09-10 DATED 18/05/2009

(TWO PART)

For Design, Fabrication, Factory testing, Installation, Commissioning & Testing at site of One Integrated Power Supply on turnkey basis. The Integrated Power Supply consists of a HVDC (High Voltage DC) Power Supply and three auxiliary power supplies with typical output ratings as mentioned below.

S.No.	POWER SUPPLY	RATING	QUANTITY
1.	HVDC Power Supply (HVPS)	15kV DC, 28Amp	1Unit
2.	CG Power Supply (CGPS)	500V DC, 2Amp	1Unit
3.	SG Power Supply (SGPS)	1500V DC, 1Amp	1Unit
4.	FL Power Supply (FLPS)	20V DC, 450Amp	1Unit

NOTE: THIS IS A TWO PART TENDER. KINDLY SUBMIT TECHNICAL BID & TERMS AND CONDITIONS (PART-A{I} & PART-A{II}) AND PRICE BID (PART-B) SEPARATELY IN TWO DIFFERENT ENVELOPES SUPERSCRIBING TECHNICAL BID AND COMMERCIAL BID IN ONE SINGLE ENVELOPE

NOTE:

1. Full details and specifications of the items and general instructions to be followed regarding submission of tenders are indicated in the tender documents.
2. **Proof for fulfillment of eligibility criteria mentioned hereunder should be submitted along with the tender. If the tender is submitted without valid documents, we shall not consider your offer. Tenders received without proof of eligibility criteria will be rejected.**
3. Tender documents can also be obtained by submitting a written request to the Purchase Officer together with prescribed tender fee, provided that the eligibility criteria is fulfilled. Last date for issue of Tender documents is 5-6-2009.
4. While requesting for Tender Documents, such request shall indicate the **“REQUEST FOR TENDER DOCUMENTS AGAINST TENDER NOTICE NO.IPR/TN/PUR/014/09-10 DATED 18/05/2009”**.
5. The tender fee of Rs.200/- (non refundable) should be made in the form of **DEMAND DRAFT from any nationalized/scheduled bank drawn in favour of Institute for Plasma Research and payable at Ahmedabad.** Vendor's name and tender number shall be indicated on the reverse side of the Demand Draft.
6. **DD should not be prior dated to the date of advertisement. Separate request letter and separate Demand Draft shall be sent for each tender.**
7. Those who use the downloaded tender documents from IPR Website may submit the prescribed Tender Fee keeping in a separate envelope along with the tender.
8. **Tenders received without the prescribed tender fee will be rejected.**

9. No request for the extension of due date will be considered.
10. Late/Delayed offers will not be accepted.
11. **Tender in a sealed envelope (Technical specifications - Part-A(i), Commercial Terms and Conditions - Part-A(ii) & EMD in one envelope and Price Bid - Part-B in another envelope) superscribing the envelope with the above tender no., date, due date and brief description of tendered item should be submitted to the *Purchase Officer* at the above address by 1.00 p.m. on 9th July, 2009. Part-A (Technical Bid, Commercial terms and conditions along with Tender Fee of Rs.200/- and EMD for Rs.20,000/-) received upto 1.00 p.m. on 9-7-2009 will be opened on the same day at 3.00 p.m. in the presence of attending tenderers.**
12. In the event of any date indicated above is a declared Holiday, the next working day shall become operative for the respective purpose mentioned herein.
13. IPR will not be responsible for any delay/loss of documents in transit.
14. Tenders received without the details asked for including proof of eligibility for participating in the tender may not be considered.
15. Tenderers should furnish/enclose full technical details/literature, delivery period and confirm the terms and conditions attached with the tender.
16. **Those who do not meet with the eligibility criteria need not submit Tender.**
17. **Those who are quoting on behalf of their foreign Principals should submit a Proforma Invoice of Foreign Principals in foreign currency.**
18. The Director, IPR reserves the right to accept or reject any offer in full or part thereof without assigning any reason thereof.
19. **Quotations received without EMD will not be considered.**

ELIGIBILITY CRITERIA: The bidders should fulfill all the following

1. The bidder must have supplied a regulated power supply or drives of output rating 6kV or higher.
2. The bidder must have supplied a regulated power supply of output rating 400A DC or higher.
3. The bidder must have proven experience in supplying Programmable Logic Controllers (PLC) based automated control power supply or any other systems.
4. The bidder must have supplied a regulated power supply of cost Rs.50,00,000/- or higher with single order.
5. Proof and customer details for all the above (Sr.No.1 to 4) must be attached with the tender. Visit for the same must be made available to the IPR representative before the Purchase Order is placed.

NOTE: Issue of tender documents does not mean that a vendor is qualified to submit tenders. IPR's decision to consider as to whether a vendor has met with the eligibility criteria is final.

PART-A(i)

Design, Fabrication, Factory testing, Installation, Commissioning & Testing at site of One Integrated Power Supply on turnkey basis. The Integrated Power Supply consists of a HVDC (High Voltage DC) Power Supply and three auxiliary power supplies with typical output ratings as mentioned below.

S.No.	POWER SUPPLY	RATING	QUANTITY
1.	HVDC Power Supply (HVPS)	15kV DC, 28Amp	1Unit
2.	CG Power Supply (CGPS)	500V DC, 2Amp	1Unit
3.	SG Power Supply (SGPS)	1500V DC, 1Amp	1Unit
4.	FL Power Supply (FLPS)	20V DC, 450Amp	1Unit

All of the four individual power supplies are PLC controlled and interconnected in a specific configuration for operation. All outputs of the four individual power supplies shall be floating at respective voltages specified. One of the individual power supplies will be grounded at the load end. The load will be placed within 10meters of the integrated supply. The details are provided in the general specifications.

A. SCOPE OF BIDDER

1. Design, Fabrication, Factory testing, Installation, Commissioning & Testing at site of the Integrated Power Supply (Qty. 1No) on turnkey basis.
2. All works are in bidder's scope except civil works.
3. Quote for additional cable per meter in case of main input at IPR is available farther away than 50m.

B. SCOPE OF PURCHASER (IPR)

1. Civil works as per detailed drawings that shall be supplied by the bidder.
2. Mains input (3 ϕ , Neutral & Power Earth) within IPR available at more than 50m of the Integrated Power Supply.
3. Dummy / Actual load for all the individual power supplies within 10m of the Integrated Power Supply at IPR.
4. System ground point shall be provided within 5m of the Load.

NOTE: All the attached data sheets must be filled and attached with the quotation. The quotations without filled in data sheets may summarily be rejected.

1. SPECIFICATIONS

A. GENERAL SPECIFICATION

The Integrated Power Supply will be constituted with four individual power supplies namely - HVDC Power Supply (HVPS), CG Power Supply (CGPS), SG Power Supply (SGPS) and FL Power Supply (FLPS). These four will have independent transformers, rectifiers and filters.

The Integrated Power Supply shall be located indoor. Hence, all of the power transformers and rectifiers are needed to be dry type. Oil filled transformer or rectifier would not be acceptable. The individual power supplies will ultimately be PLC controlled and their output terminals connected together in a particular configuration. A typical block diagram of the Integrated Power Supply is shown in Figure1. Each of the four individual power supplies must limit the arc fault energy to ≤ 50 Joules and pass the wire-burn test as described in later sections.

Output flexible cables of copper conductor and shield (if applicable) must be provided as mentioned in the individual supply specifications. All the performance requirements are needed at load end of output cable. The load would be located within 10m of the Integrated Power Supply.

Mains input of $415 \pm 10\%$; 3 ϕ ; Neutral, Power Earth, 50Hz, 450kVA will be provided by IPR at a single point more than 50m from the Integrated Power Supply. The bidder should also provide the following,

- (1) Additional utility power connections: 230V, 2 Nos. each of 5 & 15A Sockets
- (2) Emergency UPS power connections : 230V, 2 Nos. each of 5 & 15A Sockets
- (3) Space: (Width X Depth X Height) : Preferably within 3000 X 1000 X 2400 mm
- (4) Rectifier Arrays: (i) Suitable compensation techniques must be used.
(ii) The least possible number of elements in series with sufficient current rating to accommodate crowbar current also.

Grounding must be bifurcated into Safety Ground and Load End Ground. The utility ground connection available from the mains input is termed as the Safety Ground. A separate ground pit within 5m from load end will provide a connection for the Load End Ground. All enclosures, cable shields, cable armors and power transformer cores etc of the Integrated Power Supply must be connected to Safety Ground only. Integrated Power Supply housing must be kept on a Glass fiber insulation sheet of sufficient mechanical strength. This housing must be grounded at two distinct locations with Safety Ground. There would be eight output terminals i.e. two for each of the four power supplies. Shields of these eight cables would be connected to the Safety Ground at the supply end and no connection to the Load End Ground at the load end. One of the cores out of these eight output cables would be connected to Load End Ground at the load end. The load structure and the related experiment would be connected to the Load End Ground at the load end.

B. PROGRAMMABLE LOGIC CONTROLLER (PLC) FUNCTIONS

- (1) All internal, external and input signals to the PLC should be optically isolated to more than 10kV. Output signals of the PLC may be optically isolated as and when found necessary for proper operation of the system.
- (2) Switching On/Off sequence of the individual power supplies to the load is to be programmed using PLC. The voltages should always be applied in the following sequence only,
 - (a) All of the various air & water-cooling circuits for the load must be applied first.
 - (b) Wait for 2 minutes before the biasing supplies are applicable.
 - (c) The set FLPS voltage should be applied progressively over settable 2 to 3 minutes with 10 seconds pause at the full voltage. Settable delay of 1-2min after applying full voltage.
 - (d) CGPS bias voltage.
 - (e) HVPS minimum voltage required for applying SGPS voltage.
 - (f) SGPS bias voltage.
 - (g) HVPS operating voltage.
- (3) Switching Off sequence of individual power supplies should also be programmed using PLC. SGPS voltage must be removed first. The remaining voltages should be switched off in the reverse order of the startup. SGPS voltage must always be removed first and faster within 10msec in case of any fault/failure within Integrated Power Supply or the Load.
- (4) SGPS voltage is required to be applied or removed in less than 1ms. Thyristor based fast series switch may be used to open circuit the output terminal and the shunt switch may divert the source energy to a series resistance. An isolated TTL interface to control the same should be provided through PLC or any other means. The TTL pulse (external pulse mode) may be supplied by an external source so that SGPS voltage pulse of desired width and height is available.
- (5) All cooling circuits of the load must be removed after 5min of the power supplies shut down.
- (6) With or without PLC (in case of fault), a TTL low signal must be provided to switch off the external experiment at load, within few microseconds before any of the individual supply is tripped or lowered below threshold level. TTL high should be provided otherwise.
- (7) Tripping of one supply, need to act on other individual supplies. It is required to generate signal with or without help of PLC, for external experiment at load.
- (8) The power for PLC controls and two external air blowers (2HP each) must be provided through Uninterruptible Power Supply (UPS) of suitable capacity to keep them operating for a minimum of 10minutes after AC mains failure.
- (9) The PLC of a reputed brand (Siemens, ABB etc.) may in general be included with (a) CPU of response time of $\leq 1\text{msec}$ (b) Digital Input Module of input delay $\leq 1\text{msec}$ (c) Digital Output Module (d) Analog Input Modules of more than 12bit resolution & 200Hz per channel sampling rate (e) Analog Output Modules of more than 12bit resolution & 50Hz per channel sampling rate.

Following is required for all of the individual power supplies:

- (1) Control voltages 0 to 10Volts corresponds to 0 to 1.2 X V_{max} or 0 to 1.2 X I_{max} .
- (2) Monitor voltages 0 to 10Volts corresponds to 0 to 1.2 X V_{max} or 0 to 1.2 X I_{max} .
- (3) Limit set voltages 0 to 10Volts corresponds to 0 to 1.2 X V_{max} or 0 to 1.2 X I_{max} .
- (4) Analogue dials may also correspond to 0 to 1.2 X V_{max} or 0 to 1.2 X I_{max} .
- (5) Filament current where in rush in general is 1.5 X I_{max} , control voltages, monitor voltages, limit set voltages and analogue dials should be kept upper limit corresponding to 1.5 X I_{max} .

C. MECHANICAL AND TERMINATIONS

1.	Terminations		Brass or SS Bolts only.
	(i)	HV and HV Return	Suitable Epoxy Bushing. (Else Feed through capacitors that will be supplied by IPR).
	(ii)	Panel Safety Ground	Panel should have provision to connect safety ground at two different locations.
	(iii)	Control signals	All input/output digital/analog signals should be suitably routed to terminal blocks as per four distinct sets AI, AO, DI, DO.
2.	Enclosure		All the four supplies must be in different enclosures that may be separated by common SS sheets. The supplies may be installed adjacent to each other. The separating SS sheets of 1mm thick may have ~50% of its area covered by punched holes of ~4mm diameter for air ventilation.
3.	Housing		Generally conforming to standard IS: 12063-1987 and grade IP-41. Pest proof, SS housing with removable skins and/or doors, Necessary cooling fans, Dust filters at all air entries, Panel lighting, Suitable power and control cable entries, Capacitor discharge device like Idiot Stick etc.
4.	Ambient Temperature		45 ⁰ C Maximum
5.	Cooling		Forced or Natural Air

D. SPECIFICATIONS FOR THE INDIVIDUAL POWER SUPPLIES

1. HVDC POWER SUPPLY (HVPS)		
1.	Quantity	One
2.	Power Input	415V (Taps at $\pm 10\%$); 3 ϕ ; 50Hz
3.	Output cable	Co-axial type for both HV and Return.
4.	Output Voltage (Variable)	0 to 15kV DC continuous
5.	HV Setting Precision	200V
6.	Output Current (Continuous)	0 to 28A (Exclude bleeder current at any output voltage)
7.	Short Duration Output Current	280A for 10ms at 0 to 15kV DC (1% Duty Cycle)
8.	HVDC Return Path	Insulation level for floating at ≥ 10 kV DC
9.	Ripple (Peak to Peak)	$\leq \pm 0.2\%$ at 15kV DC and $\leq \pm 1\%$ at 5kV DC
10.	Load Regulation	$\leq \pm 1\%$ (for 100% load change)
11.	Line Regulation	$\leq \pm 0.5\%$ (for $\pm 10\%$ line voltage variation)
12.	Dynamic Response	When sudden load is applied in typically 1ms.
	(i) Over / Under shoot	$\pm 1\%$ Maximum
	(ii) Settling time	≤ 3 ms to settle within $\pm 0.2\%$
13.	Stability	
	(i) Output Drift	$\leq 0.2\%$ per Hour.
	(ii) Temperature sensitivity	$\leq 0.01\%$ per $^{\circ}\text{C}$
14.	Metering	Analog Meters
	(i) Input (Selector Switch)	Voltage (415V; 3 ϕ) and Current (R, Y, B)
	(ii) Output	HVDC Voltage & Current Analog
15.	Indications	LED Based Lamps
	(i) Input	Voltage R, Y, B
	(ii) Status	Auto/Manual, Supply On/Off, Ready, External Trip, Emergency Off, Filament Delay ON (External), Doors Open, Over Voltage, Over Current, Fault Output, Load Cooling, Supply Cooling etc.
16.	Feedback	(a) Closed loop feedback control system to maintain the set output DC voltage within specified limit. (b) Necessary protections to be provided for failure of feedback signal.
17.	Controls	Manual Selector Switch
	(i) Auto	By using 0-10V external signal for corresponding 0 to 18kV HVDC at 200V settable precision
	(ii) Manual	By a front panel 10 turn readable potentiometer
18.	Manual Limits Setting (10 turn accessible potentiometer)	(a) Over Voltage Limit (18kV) (b) Over Current Limit (33.6A)
19.	Analog Input (AI) signals (0 to 10V)	(a) Voltage Set (Auto Mode)
20.	Analog Output (AO) Signal (0 to 10V)	(a) DC Output Voltage (b) DC Output Current (c) Bleeder current

21.	Digital Input (DI) Signals (TTL / Potential Free Contact PFC)	(a) Fast Trip (b) Slow Trip (c) Start / Stop	-TTL (Crowbar in μ s) -PFC (without crowbar in ms) -PFC (Normal Start or Stop)
22.	Digital Output (DO) Signals (TTL / Potential Free Contact PFC)	(a) Supply Trip (b) Supply ON (c) Ready for SGPS (d) Supply OFF (e) Over Voltage Fault (f) Over Current Fault (g) Supply Fault (h) Crowbar Fired (i) Interlock Open	-TTL -TTL -TTL -TTL -TTL -TTL -PFC -TTL -TTL
23.	Protections	All active high or as suitable for fool proof operation	
	(i) Series Resistance	(2X10) 20 Ω Non Inductive Non Capacitive	
	(ii) Shunt Resistance	Suitable Bleeder \geq 500W for Stable Operation	
	(iii) Arc Protection	To be provided with (light activated) HVDC chamber	
	(iv) DC Over Voltage	Settable from 3 to 18kV	
	(v) DC Over Current	(a) Settable from 20 to 120% of rating measured on HT, (b) Series over current relay set at 120% of rating.	
	(vi) High di/dt (Load Arc)	Rate of current rise sensed by a pulse CT	
	(vii) Crowbar Trigger for Fault Energy \leq 50Joules (Wire burn test)	Within 10 μ s including detection by Over Voltage, Over Current, High di/dt, External Trip, Additional Inputs etc.	
	(viii) Others	Interlocks according to switching on/off sequence, Doors open, HV On, Danger markings etc.	
24.	Interlock		
	(i) Self	Power Supply Open/Close for OFF/ON Power Supply Cooling OK Load Water Cooling OK Bleeder over Current Air Cooling OK	-PFC -PFC -PFC -PFC -PFC
	(ii) Other Supplies	Trip SGPS and then HVPS if (1) HVPS faults (2) CGPS faults e.g. Under Voltage, Over Current and (3) FLPS faults.	
25.	Possible Topology (Any other more suitable may be quoted)	Single or Multiple Modules including Bridge rectifier, Filter, Controlled PWM at primary of HF transformer, HF rectifier, filter, crowbar, feedback and monitoring etc. PWM at DC output is not preferred.	

2. CG POWER SUPPLY (CGPS)		
1.	Quantity	One
2.	Power Input	415V; 3 ϕ (Taps at \pm 10%); 50Hz
3.	AC Mains Filter	Suitable EMI/EMC modular filter
4.	Output cable	Co-axial type for both Supply and Return.
5.	Output Voltage (Variable)	200 to 500V DC continuous
6.	Voltage Setting Precision	2V DC
7.	Output Current (Continuous)	0 to 2A (Exclude bleeder current at any output voltage)
8.	HVDC Return Path	Insulation level for floating at \geq 10kV DC

9.	Ripple (Peak to Peak)	$\leq \pm 0.1\%$ of full scale (at any voltage)
10.	Load Regulation	$\leq \pm 1\%$ (for 100% load change)
11.	Line Regulation	$\leq \pm 0.5\%$ (for $\pm 10\%$ line voltage variation)
12.	Dynamic Response	When sudden load is applied in typically 1ms.
	(i) Over / Under shoot	$\pm 1\%$ Maximum
	(ii) Settling time	$\leq 3\text{ms}$ to settle within $\pm 0.2\%$
	(iii) Current rise time	$\sim 1\text{ms}$
13.	Stability	
	(i) Output Drift	$\leq 0.2\%$ per Hour.
	(ii) Temperature sensitivity	$\leq 0.01\%$ per $^{\circ}\text{C}$
14.	Metering at Output	V & I Analog Meters
15.	Indications	LED Based Lamps
	(i) Input	Voltage R, Y, B as applicable
	(ii) Status	Auto/Manual, CGPS On/Off, Ready to Start, Trip Status, Over Voltage, Over Current, Under Voltage, Fault Output, etc.
16.	Feedback	(a) Closed loop feedback control system to maintain the set output DC voltage within specified limit. (b) Necessary protections to be provided for failure of feedback signal.
17.	Controls	Manual Selector Switch
	(i) Auto	By using 0-10V external signal for corresponding 200-500V DC at 2V settable precision
	(ii) Manual	By a front panel 10 turn readable potentiometer
18.	Manual Limits Setting (10 turn accessible potentiometer)	(a) Over Voltage Limit (b) Over Current Limit (c) Under Voltage Limit
19.	Analog Input (AI) signals (0 to 10V)	(a) Voltage Set (Auto Mode)
20.	Analog Output (AO) Signal (0 to 10V)	(a) DC Output Voltage (b) DC Output Current (c) Bleeder Current
21.	Digital Input (DI) Signals (TTL / Potential Free Contact PFC)	(a) Start / Stop –PFC (Normal Start or Stop)
22.	Digital Output (DO) Signals (TTL / Potential Free Contact PFC)	(a) Supply Trip –TTL (b) Supply ON –TTL (c) Supply Ready –TTL (d) Supply OFF –TTL (e) Over Voltage Fault –TTL (f) Over Current Fault –TTL (g) Supply Fault –PFC (h) Interlock Open –TTL
23.	Protections	All active high or as suitable for fool proof operation
	(i) Series Resistance	50 Ω Non Inductive Non Capacitive
	(ii) Shunt Resistance	Suitable Bleeder $\geq 25\text{W}$ for Stable Operation
	(iii) DC Over Voltage	Settable from 300 to 600V
	(iv) DC Over Current	Settable from 20 to 120% of rating.

	(v)	DC Under Voltage	Settable from 100 to 300V
	(vi)	Others	Interlocks to coordinate switch on/off sequence, Doors open, Danger markings etc.
24.	Interlock		Power Supply Open/Close for OFF/ON -PFC Bleeder over Current -PFC External Interlock -PFC (Open–CGPS OFF; Close- CGPS ON)
25.	Possible Topology (Any other more suitable may be quoted)		Single Module including Bridge rectifier, Filter, Controlled PWM at primary of HF transformer, HF rectifier, filter, crowbar, feedback and monitoring etc. PWM at DC output is not preferred.

3. SG POWER SUPPLY (SGPS)			
1.	Quantity		One
2.	Power Input		415V (Taps at $\pm 10\%$); 3 ϕ ; 50Hz
3.	AC Mains Filter		Suitable EMI/EMC modular filter
4.	Output cable		Co-axial type for both HV and Return.
5.	Output Voltage (Variable)		0 to 1.5kV DC continuous
6.	Voltage Setting Precision		50V DC
7.	Output Current (Continuous)		0 to 1A (Exclude bleeder current at any output voltage)
8.	Reverse Current		0 to 0.5Amp (To be absorbed before the output voltage is increased)
9.	HVDC Return Path		Insulation level for floating at ≥ 10 kV DC
10.	Ripple (Peak to Peak)		$\leq \pm 0.1\%$ of full scale (at any voltage)
11.	Load Regulation		$\leq \pm 1\%$ (for 100% load change)
12.	Line Regulation		$\leq \pm 0.5\%$ (for $\pm 10\%$ line voltage variation)
13.	Dynamic Response		When load is applied in typically 200 μ s.
	(i)	Over / Under shoot	$\pm 1\%$ Maximum
	(ii)	Settling time	$\leq 200\mu$ s to settle within $\pm 0.2\%$
	(iii)	Current rise time	$\sim 200\mu$ s
	(iv)	Fault Turn Off Time	200 μ s
14.	Stability		
	(i)	Output Drift	$\leq 0.2\%$ per Hour.
	(ii)	Temperature sensitivity	$\leq 0.01\%$ per $^{\circ}$ C
15.	Metering at Output		V & I Analog Meters
16.	Indications		LED Based Lamps
	(i)	Input	Voltage R, Y, B as applicable
	(ii)	Status	Auto/Manual, SGPS On/Off, Ready to Start, Trip Status, Over Voltage, Over Current, Fault Output, etc.
17.	Feedback		a. Closed loop feedback control system to maintain the set output DC voltage within specified limit. b. Necessary protections to be provided for failure of feedback signal.
18.	Controls		Manual Selector Switch
	(i)	Auto	By using 0-10V external signal for corresponding 0-1.8kV DC at 50V settable precision
	(ii)	Manual	By a front panel 10 turn readable potentiometer

19.	Manual Limits Setting (10 turn accessible potentiometer)	(a) Over Voltage Limit (b) Over Current Limit (c) Reverse Current Limit
20.	Analog Input (AI) signals (0 to 10V)	(a) Voltage Set (Auto Mode)
21.	Analog Output (AO) Signal (0 to 10V)	(a) DC Output Voltage (b) DC Output Current (c) DC Reverse Current (d) Bleeder Current
22.	Digital Input (DI) Signals (TTL / Potential Free Contact PFC)	(a) Fast Trip -TTL (Crowbar in μ s) (b) Slow Trip -PFC (without crowbar in ms) (c) Start / Stop -PFC (Normal Start or Stop)
23.	Digital Output (DO) Signals (TTL / Potential Free Contact PFC)	(a) Supply Trip -TTL (b) Supply ON -TTL (c) Supply Ready -TTL (d) Supply OFF -TTL (e) Over Voltage Fault -TTL (f) Over Current Fault -TTL (g) Supply Fault -PFC (h) SGPS Crowbar Fired -TTL (i) Interlock Open -TTL (j) Reverse current Fault -TTL
24.	Protections	All active high or as suitable for fool proof operation
	(i) Series Resistance	10 Ω Non Inductive Non Capacitive
	(ii) Shunt Resistance	Suitable Bleeder \geq 50W for Stable Operation
	(iii) DC Over Voltage	Settable from 500 to 1800V
	(iv) DC Over Current	(a) Settable from 20 to 120% of rating. (b) Series over current relay set at 120% of rating.
	(v) Reverse Current	Settable from 20 to 120% of rating.
	(vi) HVPS Voltage	SGPS can be switched ON only if HVPS Voltage is more than 3 to 8kV (Settable)
	(vii) Fast Switching	Thyristor based series switch may be used to open circuit the output terminal and the shunt switch may divert the source energy to a series resistance before the power controller is pulsed blocked or supply is tripped by other means.
	(viii) Others	Spark-gap (1.5kV), Interlocks to coordinate switch on/off sequence, Door open, Danger marking etc.
25.	Interlock	Power Supply Open/Close for OFF/ON -PFC HVPS Voltage \geq 5kV -TTL (Trip SGPS if HVPS Voltage <5kV) Bleeder over Current -PFC External Interlock -PFC (Open-SGPS OFF; Close- SGPS ON)
26.	Possible Topology (Any other more suitable may be quoted)	Single Module including Bridge rectifier, Filter, Controlled PWM at primary of HF transformer, HF rectifier, filter, crowbar, feedback and monitoring etc. PWM at DC output is not preferred.

4. FL POWER SUPPLY (FLPS)		
1.	Quantity	One
2.	Power Input	415V (Taps at $\pm 10\%$); 3 ϕ ; 50Hz
3.	AC Mains Filter	Suitable EMI/EMC modular filter
4.	Output cable	Suitable flexible cable for both Supply and Return.
5.	Output Voltage (Variable)	0 to 20V DC Continuous
6.	Voltage Setting Precision	0.1 V
7.	Output Current (Continuous)	0 to 450A (Exclude bleeder current at any output voltage)
8.	Max. Surge Current	$\leq 900A$
9.	Standby operation Mode	Soft Reduce/ Increase by settable 3 to 5V in 1min.
10.	FLPS/ HVPS Return Path	Insulation level for floating at $\geq 10kV$ DC
11.	Ripple (Peak to Peak)	$\leq \pm 1\%$ of full scale (at any voltage)
12.	Load Regulation	$\leq \pm 1\%$ (for 100% load change)
13.	Line Regulation	$\leq \pm 0.5\%$ (for $\pm 10\%$ line voltage variation)
14.	Dynamic Response	When load is applied in typically 1ms.
	(i) Over / Under shoot	$\pm 2\%$ Maximum
	(ii) Settling time	$\leq 20ms$ to settle within $\pm 0.5\%$
	(iii) Voltage rise time	Soft Start (0 to 20V) in 2 to 3min. (Settable)
	(iv) Fault Turn Off Time	2ms
15.	Stability	
	(i) Output Drift	$\leq 0.2\%$ per Hour.
	(ii) Temperature sensitivity	$\leq 0.01\%$ per $^{\circ}C$
16.	Metering at Output	V & I Analog Meters
17.	Indications	LED Based Lamps
	(i) Input	Voltage R, Y, B
	(ii) Status	Auto/Manual, FLPS Delay ON, FLPS On/Off, Ready to Start, Trip Status, Over Voltage, Over Current, Fault Output etc.
18.	Feedback	a) Closed loop system to control & maintain the set output DC voltage within specified limit. b) Necessary protections to be provided for failure of feedback signal.
19.	Controls	Manual Selector Switch
	(i) Auto	By using 0-10V external signal for corresponding 0-24V DC at 0.1V settable precision
	(ii) Manual	By a front panel 10 turn readable potentiometer
20.	Manual Limits Setting (10 turn accessible potentiometer)	(a) Over Voltage Limit (b) Over Current Limit
21.	Analog Input (AI) signals (0 to 10V)	(a) Voltage Set (Auto Mode)
22.	Analog Output (AO) Signal (0 to 10V)	(a) DC Output Voltage (b) DC Output Current (c) Floating Voltage (d) Bleeder Current

23.	Digital Input (DI) Signals (TTL / Potential Free Contact PFC)	(a) Start / Stop -PFC (Normal Start or Stop)
24.	Digital Output (DO) Signals (TTL / Potential Free Contact PFC)	(a) Supply Delay ON -TTL (b) Supply ON -TTL (c) Supply Ready -TTL (d) Supply OFF -TTL (e) Over Voltage Fault -TTL (f) Over Current Fault -TTL (g) Supply Fault -PFC (h) Cooling Interlock Open -TTL
25.	Protections	All active high /as suitable for fool proof operation
	(i) Shunt Resistance	Suitable Bleeder $\geq 100W$ for Stable Operation
	(ii) DC Over Voltage	Settable from 15 to 24V
	(iii) DC Over Current	(a) Settable from 20 to 120% of rating. (b) Series over current relay set at 120% of rating.
	(iv) Others	Interlocks to coordinate switch on/off sequence, Doors open, Danger markings etc.
26.	Interlock	Power Supply Open/Close for OFF/ON -PFC Air Blower Fault -PFC Water Cooling Fault -PFC Bleeder over Current -PFC External Interlock -PFC (Open-FLPS OFF; Close- FLPS ON) Zero Start (Limit Switch) - PFC
27.	Possible Topology (Any other more suitable may be quoted)	Single or Multiple Modules including Bridge rectifier, Filter, Controlled PWM at primary of HF transformer, HF rectifier, filter, crowbar, feedback and monitoring etc. PWM at DC output is not preferred.

E. ACCEPTANCE TESTS PROCEDURE

GENERAL

This will include tests to ensure that the Integrated Power Supply meets all the above-mentioned specifications. The tests will be carried out at the factory before dispatch and at Institute for Plasma Research during commissioning. The tests mentioned below are to be performed as minimum required and will be elaborated within three months of placing the order with mutual discussions and understanding.

TESTS TO BE PERFORMED

(i) COMPONENT LEVEL: Brand names of most of the major components to be used must be submitted with the quotation. Sufficient margins must be kept to ensure smooth operation and longer life of the Integrated Power Supply. Only reputed brands and make should be used.

Specifications and Tests Reports of every individual component that is used in fabrication of the Power Supply must be submitted. Submit the technical data sheet of the components where such tests are not possible to be conducted.

(ii) SUBSYSTEM LEVEL: Stage wise progress will be monitored. IPR representative should be invited for witnessing the relevant tests at pre-decided time intervals in order to ensure quality and optimized progress. The stage wise progress that should be executed in order to complete the specified Integrated Power Supply in the given time duration will be elaborated within one month of placing the order with mutual discussions and understanding.

(iii) INDIVIDUAL POWER SUPPLIES: Each of the specified HVPS, CGPS, SGPS and the FLPS must be tested for the following,

Sl.No	Specification	Tests to be Performed
1.	No-load test	Rise time, Fall time, Voltage setting resolution, Minimum DC output Voltage, Maximum DC output Voltage etc.
2.	Load Test	Rise time, Fall time, Voltage setting resolution, Minimum DC output Voltage, Maximum DC output Voltage, Load Regulation, Line regulation, Dynamic Response, Ripple, Stability etc.
3.	Monitoring	Resolution, Accuracy, Calibration etc.
4.	Control	Auto, Manual Mode of Operation.
5.	Settings	Settable Parameters are Over Voltage, Over Current etc.
6.	Floating	HVPS return floated to 10kV with respect to ground (With observation of effect on monitoring signals).
7.	Indications	Proper operation of monitors, indicators and signals like AI, AO, DI, DO etc.
8.	Protections	Proper operation of all protections and Interlocks.
9.	Shielding	Effectiveness in terms of EMI/EMC within and outside the Individual and Integrated Power Supply.
10.	Wire-burn test	With 30AWG (Diameter 0.225mm), 6'' long soft copper wire for fault energy <50Joules as per attached details.
11.	Others	Remaining of the specifications.

(iv) OVERALL INTEGRATED POWER SUPPLY: At least following must be tested,

- (1) Systematic switching On/Off of the individual power supplies as per given sequence, specified and settable delays. Performance of various inter-supplies interlocks.
- (2) Continuous full load operation of the power supply system for more than 8Hours without performance degradation.
- (3) Temperature within the Power Supply should not be raised 10 degrees above ambient while in equilibrium during continuous operation.
- (4) Performance of each of the above mentioned parameters of the power supplies while operating simultaneously with the remaining power supplies in a particular configuration.
- (5) Remote operation of the integrated power supply.

F. WIRE BURN TEST PROCEDURE

GENERAL

The fault sensing element for Over Voltage, Over Current and other protections etc must sense a fault condition. The fault signals i.e. signal above threshold will trigger the crowbar. The crowbar is a fault energy-diverting element such as thyatron, ignitron, SCR etc. Typical fault energy diverting element fires within few microseconds of the fault detection and remove all voltages and currents from the load in few microseconds.

TESTING PROCEDURE

The individual power supplies namely- HVPS, CGPS, SGPS and FLPS need this testing. The power supply should be short circuited through 6 inch long soft copper wire of diameter 0.255mm i.e. 30AWG. The wire should remain intact. This ensures that total energy delivered after fault is less than 50 Joules. These 50 Joules of fault energy includes energy from the storage devices and the follow on current from the power supply before tripping.

DETAILS OF OPERATION

HVDC POWER SUPPLY: The resistance R1 (Figure 2) is used to limit the peak current into the fault energy diverting element and load on the transformer & rectifier. R2 should be large enough to keep sufficient voltage across fault energy diverting element required for proper firing. R1 and R2 should be such as to damp the circuit ringing sufficiently for preventing current reversal into the fault energy-diverting element. This may cause the fault energy-diverting element to open before the fault conditions are cleared. Crowbar test switch is a high voltage air or vacuum construction.

SG POWER SUPPLY: A series resistance is used to limit the peak current into the load. A series thyristor based switch that is included for fast pulsing of the power supply may be used to open circuit the output terminal in case of fault. Another shunt thyristor based switch may divert the fault energy to a series resistance in the return path before the power controller is pulse blocked or supply is tripped by other means.

OTHER POWER SUPPLIES: A series resistance is used to limit the peak current into the load. The pulse block feature of the power controller will trip the power supply and therefore restricting the fault energy. Stored energy should be least and the pulse block after fault should be fast enough to ensure that total energy delivered after fault is less than 50 Joules.

2. DATA-SHEETS

A. THE INTEGRATED POWER SUPPLY

S.NO	DESCRIPTION	VALUE REQUIRED	VALUE OFFERED
1.	Scope of bidder	As specified	
2.	Scope of purchaser	Only civil work	
3.	Mains input voltage	415V±10%; 3φ; 50Hz; N, PE;	
4.	Input Power	450kVA	
5.	System suitability	Indoor	
6.	All power transformers	Dry type only	
7.	All rectifiers	Dry type only	
8.	Use of oil	Not recommended anywhere	
9.	Performance terminals	Load end of the output cables	
10.	Supply to load distance	10m	
11.	Grounding scheme	As specified	
12.	Insulation used for installation of housing	Thickness of the insulation	
13.	UPS power	As suitable	
14.	UPS sockets	230V, 5 & 15A (2 Nos. each)	
15.	Spare utility sockets	230V, 5 & 15A (2 Nos. each)	
16.	Fault energy of each power supply	≤ 50Joules	
17.	Total Preferred Space	W 3000 X D 1000 X H 2400mm (Increase in width is possible)	
18.	Shielding from one supply to another	Use SS sheets as specified	
19.	Shielding from Power Supply to outside	Use SS sheets as specified	
20.	Rectifier Arrays	(i) Suitable compensation techniques must be used. (ii) Least possible number of elements in series, with sufficient current rating to accommodate crowbar current.	
21.	Is Topology as per specifications or different? (Submit details)	(i) HVDC Power Supply	
		(ii) CG Power Supply	
		(iii) SG Power Supply	
		(iv) FL Power Supply	

B. PLC FUNCTIONS

S.NO	DESCRIPTION/ SPECIFICATION	VALUE OFFERED
1.	All internal, external and input signals to PLC should be optically isolated for $\geq 10\text{KV}$.	
2.	Switching On/Off sequence of individual power supplies to be programmed using PLC.	
3.	The voltages would always be applied in the mentioned sequence only.	
4.	Switching Off sequence of individual power supplies would also be programmed using PLC.	
5.	SGPS voltage must be switched Off first.	
6.	The remaining voltages should be switched off in the reverse order of startup.	
7.	SGPS voltage is required to be applied or removed in less than 1ms. Thyristor based fast series switch may be used to open circuit the output terminal and the shunt switch may divert the source energy to a series resistance. An isolated TTL interface to control the same should be provided. The TTL pulse may be supplied by an external source so that SGPS voltage pulse of desired width and height is available.	
8.	SGPS voltage must be removed first and faster within 10ms in case of any fault/failure within integrated power supply or the load.	
9.	All of the load cooling circuits must be removed only after 5min of the biasing supplies are shut down.	
10.	With or without PLC, TTL low signal must be provided to switch off the external experiment at load, within few microseconds in case of a fault before any of the supply is tripped or lowered below threshold level. TTL high should be provided otherwise.	
11.	Tripping of one supply need to act on other supplies. It should also generate signal for load & external experiment with or without help of PLC.	
12.	Reputed brand of the PLC (Siemens, ABB etc).	
13.	(a) CPU of response time of $\leq 1\text{msec}$	
	(b) Digital Input Module of input delay $\leq 1\text{msec}$	
	(c) Digital Output Module	
	(d) Analog Input Modules of more than 12bit resolution & 200Hz per channel sampling rate	
	(e) Analog Output Modules of more than 12bit resolution & 50Hz per channel sampling rate.	

C. MECHANICAL AND TERMINATIONS

S.NO	DESCRIPTION	VALUE REQUIRED	VALUE OFFERED
1.	Bolts	Brass or SS Bolts only.	
2.	Terminations		
	(i) HV and Return	Suitable Epoxy Bushing. (Else Feed through capacitors that will be supplied by IPR).	
	(ii) Panel Safety Ground	Panel should have provision to connect safety ground at two different locations	
	(iii) Control signals	All input/output digital/analog signals should be suitably routed to terminal blocks as per four distinct sets AI, AO, DI, DO.	
3.	Enclosure	All the four individual supplies must be in different enclosures that may be separated by common SS sheets. The supplies may be installed adjacent to each other. The separating 1mm thick SS sheets may have ~50% of its area covered by punched holes of diameter ~4mm for air ventilation.	
4.	Housing	Generally conforming to standard IS:12063-1987 and grade IP-41.	
		Pest proof, SS housing with removable skins and/or doors, Necessary cooling fans, Dust filters at all air entries, Panel lighting, Suitable power and control cable entries, Capacitor discharge device like Idiot Stick etc.,	
5.	Ambient Temp.	45 ⁰ C Maximum	
6.	Cooling	Forced or Natural Air	

D. INDIVIDUAL POWER SUPPLIES

1. HVDC POWER SUPPLY (HVPS)				
S.NO	DESCRIPTION		VALUE REQUIRED	VALUE OFFERED
1.	Power Input		415V (Taps at $\pm 10\%$); 3 ϕ ; 50Hz	
2.	Output cable		Co-axial type: HV and Return.	
3.	Output Voltage		0 to 15kV DC continuous	
4.	HV Setting Precision		200V	
5.	Output Current		0 to 28A (Exclude bleeder current at any output voltage)	
6.	Short Duration Output Current		280A for 10ms at 0 to 15kV DC (1% Duty Cycle)	
7.	HVDC Return Path		Insulation level ≥ 10 kV DC	
8.	Ripple (Peak to Peak)		$\leq \pm 0.2\%$ at 15kV DC and $\leq \pm 1\%$ at 5kV DC	
9.	Load Regulation		$\leq \pm 1\%$ (for 100% load change)	
10.	Line Regulation		$\leq \pm 0.5\%$ ($\pm 10\%$ line variation)	
11.	Dynamic Response		When sudden load is applied in typically 1ms.	
	(i)	Over /Under shoot	$\pm 1\%$ Maximum	
	(ii)	Settling time	≤ 3 ms to settle within $\pm 0.2\%$	
	(iii)	Current rise time	~ 1 ms	
12.	Stability			
	(i)	Output Drift	$\leq 0.2\%$ per Hour.	
	(ii)	Temp. Sensitivity	$\leq 0.01\%$ per $^{\circ}\text{C}$	
13.	Metering		Analog Meters	
	(i)	Input (Selector Switch)	Voltage (415V; 3 ϕ) and Current (R, Y, B)	
	(ii)	Output Voltage measuring device		
		Accuracy		
	(iii)	Output current measuring device		
Accuracy				
14.	Indications		LED Based Lamps	
	(i)	Input	Voltage R, Y, B	
	(ii)	Status	Auto/Manual, Supply On/Off, Ready, External Trip, Emergency Off, Filament Delay ON (External), Doors Open, Over Voltage, Over Current, Fault Output, Load Cooling, Power Supply Cooling etc.	

15.	Feedback		Closed loop feedback control system to maintain the set output DC voltage within specified limit.	
			Necessary protections to be provided for failure of feedback signal.	
16.	Controls		Manual Selector Switch	
17.	(i)	Auto	By using 0-10V external signal for corresponding 0-18kV HVDC at 200V settable precision	
18.	(ii)	Manual	By a front panel 10 turn potentiometer	
19.	Manual Limits Setting (10 Turn potentiometer)		(a) Over Voltage Limit (18kV) (b) Over Current Limit (33.6A)	
20.	Analog Input (AI) signals (0 to 10V)		(a) Voltage Set (Auto Mode)	
21.	Analog Output (AO) Signal (0 to 10V)		(a) DC Output Voltage (b) DC Output Current (c) Bleeder Current	
	Band Width			
	Sampling Rate			
22.	Digital Input (DI) Signals (TTL / Potential Free Contact PFC)		(a) Fast Trip -TTL (b) Slow Trip -PFC (c) Start / Stop -PFC	
23.	Digital Output (DO) Signals (TTL / Potential Free Contact PFC)		(a) Supply Trip -TTL (b) Supply ON -TTL (c) Supply Ready -TTL (d) Supply OFF -TTL (e) Over Voltage Fault -TTL (f) Over Current Fault -TTL (g) Supply Fault -PFC (h) Crowbar Fired -TTL (i) Interlock Open -TTL	
24.	Protections		All active high or as required for fool proof operation	
	(i) Series Resistance		2 X 10 Ω Non Inductive Non Capacitive	
	(ii) Shunt Resistance		Suitable Bleeder \geq 500W for Stable Operation	
	(iii) Light Activated Arc Protection		To be provided with HVDC chamber	
	(iv) DC Over Voltage		Settable from 3 to 18kV	
	(v) DC Over Current		(a) Settable from 20 to 120% of rating measured on HT.	
			(b) Series over current relay set at 120% of rating.	
(vi) High di/dt (Load Arc)		Rate of current rise sensed by a pulse CT		

	(vii) Crowbar Trigger for Fault Energy $\leq 50J$ (Wire burn test)	Within 10 μ s including detection by Over Voltage, Over Current, High di/dt, External Trip, Additional Inputs etc.	
	(viii) Others	Interlocks according to switching on/off sequence, Doors open, HV On, Danger markings etc.	
25.	Interlock		
	(i) Self	Power Supply Open/Close for OFF/ON -PFC Power Supply Cooling OK -PFC Load Water Cooling OK -PFC Bleeder over Current -PFC Air Cooling OK -PFC	
	(ii) Other Supplies	Trip SGPS and then HVPS if (1) HVPS faults (2) CGPS faults e.g. Under Voltage, Over Current and (3) FLPS faults.	
26.	Possible Topology (Any other more suitable may be quoted)	Single or Multiple Modules including Bridge rectifier, Filter, Controlled PWM at primary of HF transformer, HF rectifier, filter, crowbar, feedback and monitoring etc. PWM at DC output is not preferred.	

2. CG POWER SUPPLY (CGPS)			
S.NO	DESCRIPTION	VALUE REQUIRED	VALUE OFFERED
1.	Power Input	415V; 3 ϕ (Taps at $\pm 10\%$); 50Hz	
2.	AC Mains Filter	Suitable EMI/EMC modular filter	
3.	Output cable	Co-axial type: Supply and Return.	
4.	Output Voltage	200 to 500V DC continuous	
5.	Volt Setting Precision	2V DC	
6.	Output Current	0 to 2A (Exclude bleeder current at any output voltage)	
7.	HVDC Return Path	Insulation level $\geq 10kV$ DC	
8.	Ripple (Peak to Peak)	$\leq \pm 0.1\%$ of full scale (at any voltage)	
9.	Load Regulation	$\leq \pm 1\%$ (for 100% load change)	
10.	Line Regulation	$\leq \pm 0.5\%$ (for $\pm 10\%$ line variation)	
11.	Dynamic Response	When sudden load is applied in typically 1ms.	
	(i) Over /Under shoot	$\pm 1\%$ Maximum	
	(ii) Settling time	$\leq 3ms$ to settle within $\pm 0.2\%$	
	(iii) Current rise time	~ 1 ms	

12.	Stability		
	(i)	Output Drift	$\leq 0.2\%$ per Hour.
	(ii)	Temp. Sensitivity	$\leq 0.01\%$ per $^{\circ}\text{C}$
13.	Metering at Output		V & I Analog Meters
14.	Indications		LED Based Lamps
	(i)	Input	Voltage R, Y, B as applicable
	(ii)	Status	Auto/Manual, CGPS On/Off, Ready to Start, Trip Status, Over Voltage, Over Current, Under Voltage, Fault Output, etc.
15.	Feedback		(a) Closed loop feedback control system to maintain the set output DC voltage within specified limit.
			(b) Necessary protections to be provided for failure of feedback signal.
16.	Controls		Manual Selector Switch
	(i)	Auto	By using 0-10V external signal for corresponding 200-500V DC at 2V settable precision
	(ii)	Manual	By a front panel 10 turn readable potentiometer
17.	Manual Limits Setting (10 turn potentiometer)		(a) Over Voltage Limit (b) Over Current Limit (c) Under Voltage Limit
18.	Analog Input (AI) signals (0 to 10V)		(a) Voltage Set (Auto Mode)
19.	Analog Output (AO) Signal (0 to 10V)		(a) DC Output Voltage (b) DC Output Current (c) Bleeder Current
	Band Width		
	Sampling Rate		
20.	Digital Input (DI) Signals (TTL / PFC)		(a) Start / Stop -PFC (Normal Start or Stop)
21.	Digital Output (DO) Signals (TTL / Potential Free Contact PFC)		(a) Supply Trip -TTL (b) Supply ON -TTL (c) Supply Ready -TTL (d) Supply OFF -TTL (e) Over Voltage Fault -TTL (f) Over Current Fault -TTL (g) Supply Fault -PFC (h) Interlock Open -TTL

22.	Protections		All active high or as required for fool proof operation
	(i)	Series Resistance	50Ω Non Inductive Non Capacitive
	(ii)	Shunt Resistance	Suitable Bleeder $\geq 25W$ for Stable Operation
	(iii)	DC Over Voltage	Settable from 300 to 600V
	(iv)	DC Over Current	Settable from 20 to 120%
	(v)	DC Under Voltage	Settable from 100 to 300
	(vi)	Others	Interlocks to coordinate switch on/off sequence, Doors open, Danger markings etc.
23.	Interlock		Power Supply Open/Close for OFF/ON -PFC Bleeder over Current -PFC External Interlock -PFC (Open- CGPS OFF; Close- CGPS ON)
24.	Possible Topology (Any other more suitable may be quoted)		Single Module including Bridge rectifier, Filter, Controlled PWM at primary of HF transformer, HF rectifier, filter, crowbar, feedback and monitoring etc. PWM at DC output is not preferred.

3. SG POWER SUPPLY (SGPS)				
S.NO	DESCRIPTION		VALUE REQUIRED	VALUE OFFERED
1.	Power Input		415V (Taps at $\pm 10\%$); 3 ϕ ; 50Hz	
2.	AC Mains Filter		Suitable EMI/EMC modular filter	
3.	Output cable		Co-axial type: HV and Return.	
4.	Output Voltage		0 to 1.5kV DC continuous	
5.	Voltage Setting Precision		50V DC	
6.	Output Current		0 to 1A (Exclude bleeder current at any output voltage)	
7.	Reverse Current		0 to 0.5Amp (To be absorbed before the output voltage is increased)	
8.	HVDC Return Path		Insulation level $\geq 10kV$ DC	
9.	Ripple (Peak to Peak)		$\leq \pm 0.1\%$ of full scale (at any voltage)	
10.	Load Regulation		$\leq \pm 1\%$ (for 100% load change)	
11.	Line Regulation		$\leq \pm 0.5\%$ (for $\pm 10\%$ line variation)	
12.	Dynamic Response		When load is applied in $\sim 200\mu s$.	
	(i)	Over/Under shoot	$\pm 1\%$ Maximum	
	(ii)	Settling time	$\leq 200\mu s$ to settle within $\pm 0.2\%$	
	(iii)	Current rise time	$\sim 200\mu s$	

	(iv)	Fault Turn Off Time	200 μ s	
13.	Stability			
	(i)	Output Drift	≤ 0.2 % per Hour.	
	(ii)	Temp. Sensitivity	≤ 0.01 % per $^{\circ}$ C	
14.	Metering at Output		V & I Analog Meters	
15.	Indications		LED Based Lamps	
	(i)	Input	Voltage R, Y, B as applicable	
	(ii)	Status	Auto/Manual, SGPS On/Off, Ready to Start, Trip Status, Over Voltage, Over Current, Fault Output, etc.	
16.	Feedback		Closed loop feedback control system to maintain the set output.	
			Necessary protections for failure of feedback signal.	
17.	Controls		Manual Selector Switch	
	(i)	Auto	By using 0-10V external signal for corresponding 0-1.8kV DC at 50V settable precision	
	(ii)	Manual	By a front panel 10 turn readable potentiometer	
18.	Manual Limits Setting (10 Turn potentiometer)		(a) Over Voltage Limit (b) Over Current Limit (c) Reverse Current Limit	
19.	Analog Input (AI) signals (0 to 10V)		(a) Voltage Set (Auto Mode)	
20.	Analog Output (AO) Signal (0 to 10V)		(a) DC Output Voltage (b) DC Output Current (c) DC Reverse Current (d) Bleeder Current	
	Band Width			
	Sampling Rate			
21.	Digital Input (DI) Signals (TTL / PFC)		(a) Fast Trip -TTL (b) Slow Trip -PFC (c) Start / Stop -PFC	
22.	Digital Output (DO) Signals (TTL / PFC)		(a) Supply Trip -TTL (b) Supply ON -TTL (c) Supply Ready -TTL (d) Supply OFF -TTL (e) Over Voltage Fault -TTL (f) Over Current Fault -TTL (g) Supply Fault -PFC (h) SGPS Crowbar Fired -TTL (i) Interlock Open -TTL (j) Reverse current Fault -TTL	
23.	Protections		All active high or as required for fool proof operation	

	(i)	Series Res.	10 Ω Non Inductive Non Capacitive	
	(ii)	Shunt Res.	Suitable Bleeder $\geq 50W$ for Stable Operation	
	(iii)	Over Voltage	Settable from 500 to 1500V	
	(iv)	Over Current	(a) Settable from 20 to 120%	
			(b) Series over current relay set at 120%.	
	(v)	Rev. Current	Settable from 20 to 120%	
	(vi)	HVPS Voltage	SGPS can be switched ON only if HVPS Voltage is more than 3 to 8kV (Settable Threshold)	
	(vii)	Fast Switching	Thyristor based series switch may be used to open circuit the output terminal and the shunt switch may divert the source energy to a series resistance before the power controller is pulsed blocked or supply is tripped by other means.	
	(viii)	Others	Spark-gap (1.5kV), Interlocks to coordinate switch on/off sequence, Door open, Danger marking etc.	
24.	Interlock		Power Supply OFF/ON -PFC HVPS Voltage $\geq 5kV$ -TTL Bleeder over Current -PFC External Interlock -PFC	
25.	Possible Topology (Any other more suitable may be quoted)		Single or Multiple Modules including Bridge rectifier, Filter, Controlled PWM at primary of HF transformer, HF rectifier, filter, crowbar, feedback and monitoring etc. PWM at DC output is not preferred.	

4. FL POWER SUPPLY (FLPS)			
S.NO	DESCRIPTION	VALUE REQUIRED	VALUE OFFERED
1.	Power Input	415V (Taps at $\pm 10\%$); 3 ϕ ; 50Hz	
2.	AC Mains Filter	Suitable EMI/EMC modular filter	
3.	Output cable	Suitable flexible cable for both Supply and Return.	
4.	Output Voltage	0 to 20VDC continuous	
5.	Voltage Setting Precision	0.1 V	
6.	Output Current	0 to 450A (Exclude bleeder current at any output voltage)	
7.	Max. Surge Current	$\leq 900A$	
8.	Standby operation Mode	Soft Reduce/ Increase by settable 3 to 5V in 1min.	
9.	FLPS Return Path	Insulation level $\geq 10kV$ DC	

10.	Ripple (Peak to Peak)	$\leq \pm 1\%$ of full scale (at any voltage)	
11.	Load Regulation	$\leq \pm 1\%$ (for 100% load change)	
12.	Line Regulation	$\leq \pm 0.5\%$ (for $\pm 10\%$ line variation)	
13.	Dynamic Response	When load is applied in $\sim 1\text{ms}$.	
	(i) Over/Under shoot	$\pm 2\%$ Maximum	
	(ii) Settling time	$\leq 20\text{ms}$ to settle within $\pm 0.5\%$	
	(iii) Voltage rise time	Soft Start (0 to 20V) in 2 to 3min.	
(iv)	Fault Turn Off Time	2ms	
14.	Stability		
	(i) Output Drift	$\leq 0.2\%$ per Hour.	
	(ii) Temp. Sensitivity	$\leq 0.01\%$ per $^{\circ}\text{C}$	
15.	Metering at Output	V & I Analog Meters	
16.	Indications	LED Based Lamps	
	(i) Input	Voltage R, Y, B	
	(ii) Status	Auto/Manual, Filament Delay ON, FPS On/Off, Ready to Start, Trip Status, Over Voltage, Over Current, Fault Output etc.	
17.	Feedback	a) Closed loop system to control/maintain the set output DC voltage within specified limit.	
		b) Necessary protections to be provided for failure of feedback signal.	
18.	Controls	Manual Selector Switch	
	(i) Auto	By using 0-10V external signal for 0-20V DC at 0.1V set precision	
	(ii) Manual	By a front panel 10 turn readable potentiometer	
19.	Manual Limits Setting 10 turn potentiometer	(a) Over Voltage Limit (b) Over Current Limit	
20.	Analog Input (AI) signals (0 to 10V)	(a) Voltage Set (Auto Mode)	
21.	Analog Output (AO) Signal (0 to 10V)	(a) DC Output Voltage (b) DC Output Current (c) Floating Voltage (d) Bleeder Current	
	Band Width		
	Sampling Rate		
22.	Digital Input (DI) Signals (TTL / PFC)	(a) Start / Stop -PFC (Normal Start or Stop)	

23.	Digital Output (DO) Signals (TTL / Potential Free Contact PFC)	(a) Supply Delay ON -TTL (b) Supply ON -TTL (c) Supply Ready -TTL (d) Supply OFF -TTL (e) Over Voltage Fault -TTL (f) Over Current Fault -TTL (g) Supply Fault -PFC (h) Cooling Interlock Open -TTL	
24.	Protections	All active high or as required for fool proof operation	
	(i) Shunt Resistance	Suitable Bleeder $\geq 100W$ for Stable Operation	
	(ii) DC Over Voltage	Settable from 15 to 24V	
	(iii) DC Over Current	(a) Settable from 20 to 120%.	
		(b) Series over current relay at 120% rating.	
	(iv) Others	Interlocks to coordinate switch on/off sequence, Doors open, Danger markings etc.	
25.	Interlock	Power Supply OFF/ON -PFC Air Blower Fault -PFC Water Cooling Fault -PFC Bleeder over Current -PFC External Interlock -PFC Zero Start -Limit Switch / PFC	
26.	Possible Topology (Any other more suitable may be quoted)	Single or Multiple Modules including Bridge rectifier, Filter, Controlled PWM at primary of HF transformer, HF rectifier, filter, crowbar, feedback and monitoring etc. PWM at DC output is not preferred.	

E. ACCEPTANCE TESTS PROCEDURE

S.NO	DESCRIPTION	VALUE REQUIRED	VALUE OFFERED
1.	General	The tests required to ensure that the integrated power supply meets all mentioned specifications	
		All the specified tests will be carried out at the factory or any reputed laboratory before dispatch	
		The tests will also be carried out at the Institute for Plasma Research during commissioning.	

		The tests specified will be elaborated within three months of placing the order with mutual discussions and understanding.	
2.	Tests to be performed		
	(i) Component level	Brand names of most of the major components to be used would be submitted with the quotation.	
		Sufficient margins would be kept to ensure smooth operation and longer life of the Integrated Power Supply.	
		Only reputed brands and make should be used.	
		Specifications and Tests Reports of every individual component that is used in fabrication of the Power Supply should be submitted.	
		Submit the technical data sheet of the components where such tests are not possible to be conducted.	
	(ii) Subsystem level	The stage wise progress that should be executed in order to complete the ordered requirements in the given time duration will be elaborated within one month of placing the order with mutual discussions and understanding.	
		Stage wise progress would be monitored by IPR representatives as mentioned in specification, in order to ensure quality and optimized progress.	
	(iii) Individual Power Supplies	HVPS would be tested as specified.	
		CGPS would be tested as specified.	
		SGPS would be tested as specified.	
		FLPS would be tested as specified.	
	(iv) Overall Integrated Power Supply	(1) Systematic switching On /Off of each of the Power Supplies as per given sequence and specified / settable delays. Performance of various inter-supply interlocks.	
		(2) Full load operation of the integrated power supply for more than 8Hours without performance degradation.	
		(3) Temperature within the Power Supply should not be raised 10 ⁰ C above ambient while in equilibrium during continuous operation.	

		(4) Performance of each of the above mentioned parameters of the power supplies while operating simultaneously with the remaining power supplies in a particular configuration.	
		(5) Remote operation of the integrated power supply.	
3.	Other tests proposed by bidder (if any)	HV Power Supply	
		CG Power Supply	
		SG Power Supply	
		FL Power Supply	
4.	Tests that cannot be performed on HV Power Supply		
5.	Tests that cannot be performed on CG Power Supply		
6.	Tests that cannot be performed on SG Power Supply		
7.	Tests that cannot be performed on FL Power Supply		

F. WIRE BURN TEST PROCEDURE

S.NO	DESCRIPTION	VALUE REQUIRED	VALUE OFFERED
1.	General	The fault-sensing element other than Over Voltage, Over Current and other protections must sense a fault condition. The fault signal will trigger the crowbar.	
		Proposed fault sensing element for HVPS	
		Proposed fault sensing element for CGPS	
		Proposed fault sensing element for SGPS	
		Proposed fault sensing element for FLPS	
		Fault energy diverting element fires within few μ s of the fault detection and remove all voltages and currents from the load in few μ s.	
		Proposed fault energy diverting element for HVPS	
		Proposed fault energy diverting element for CGPS	
		Proposed fault energy diverting element for SGPS	
		Proposed fault energy diverting element for FLPS	
2.	Test Procedure	As mentioned with the specifications	
3.	Operation Details	Acceptable for HV Power Supply	
		Acceptable for CG Power supply	
		Acceptable for SG Power Supply	
		Acceptable for FL Power Supply	

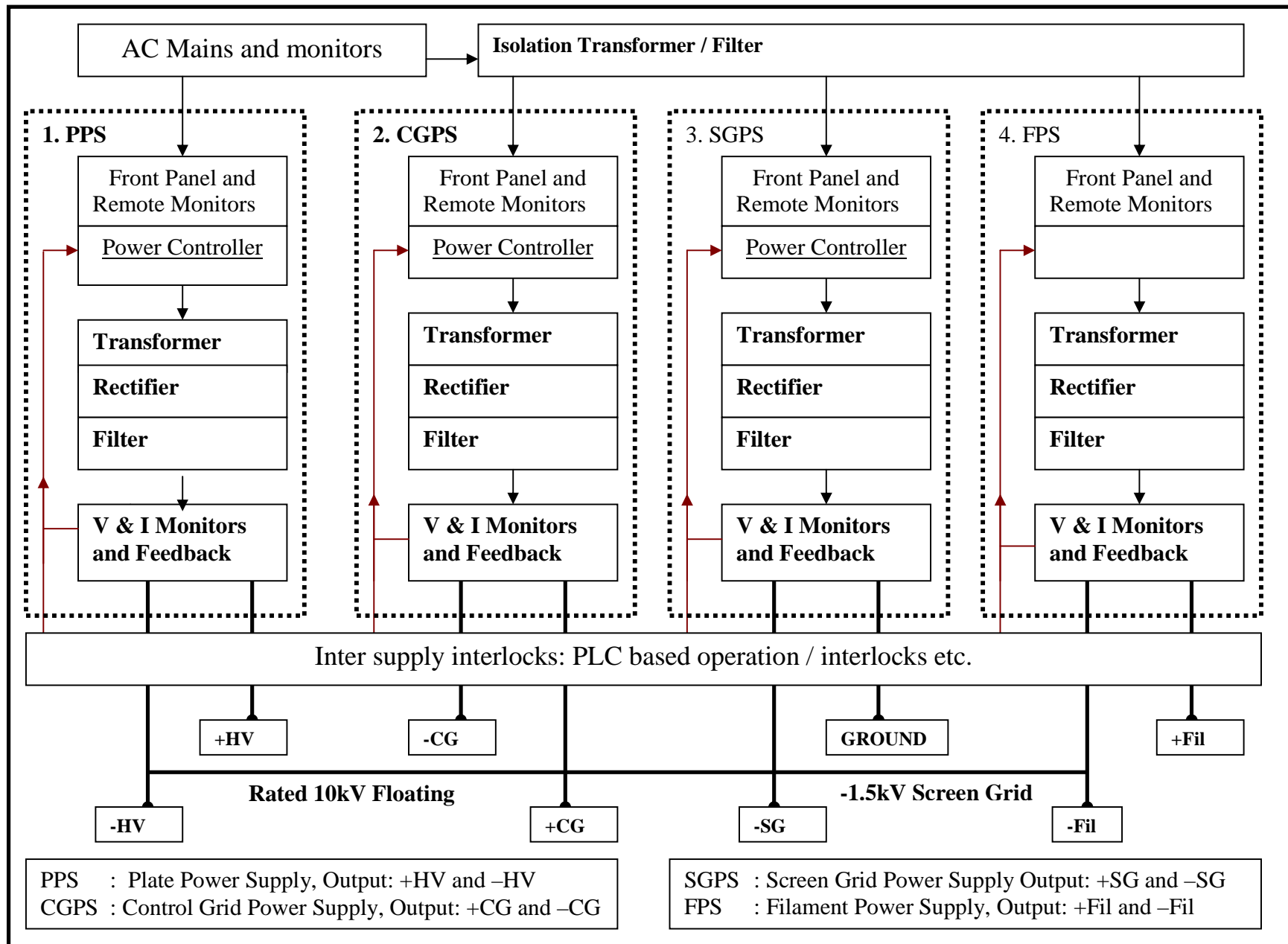

Figure 1. BLOCK DIAGRAM OF INTEGRATED POWER SUPPLY

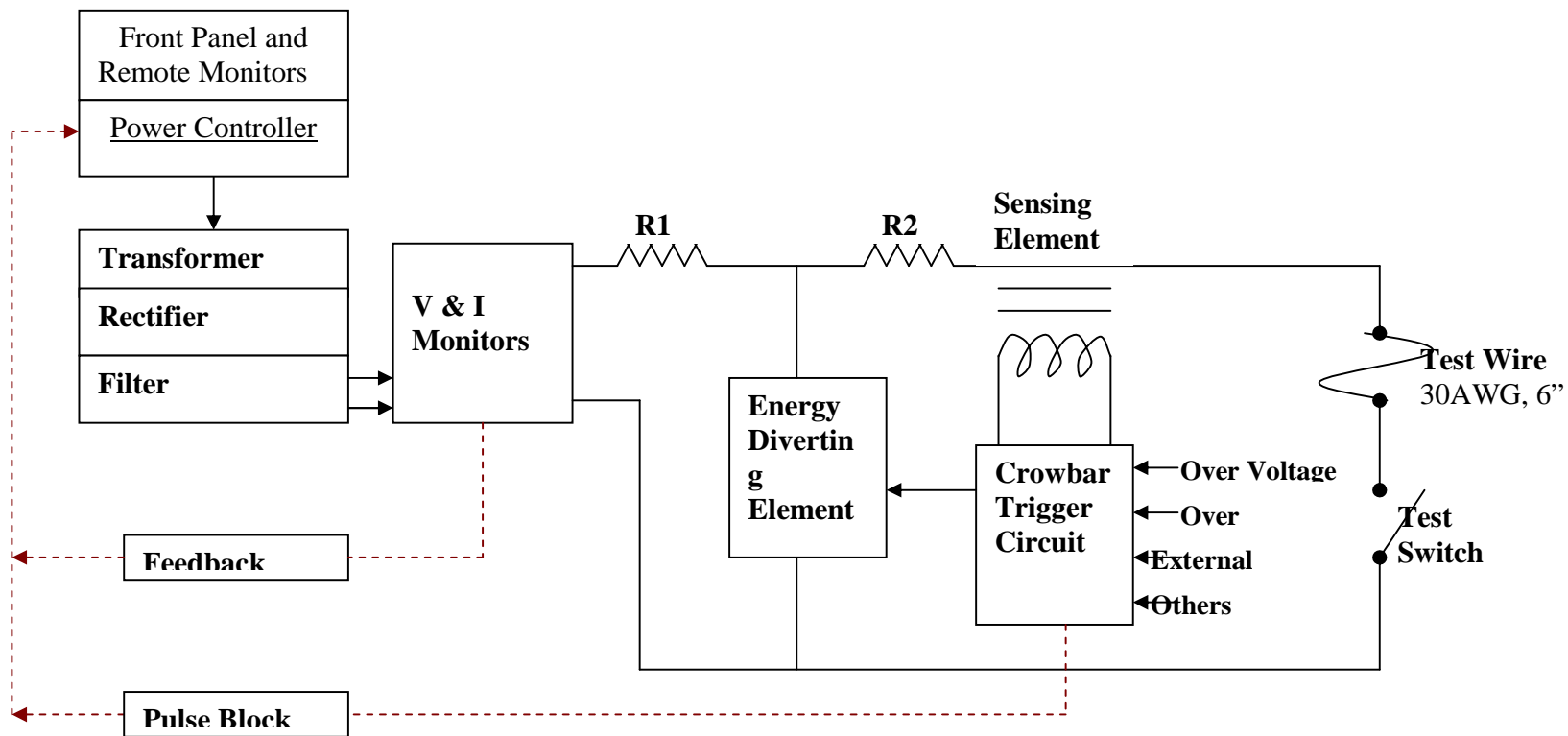

Figure 2. HVDC POWER SUPPLY: WIRE BURN TEST

BLANK PAGE

INSTRUCTIONS TO BIDDERS AND TERMS AND CONDITIONS

1. The quotation and any order resulting from this tender/enquiry shall be governed by our Conditions of contract and supplier quoting this enquiry shall be deemed to have read and understood the same in toto.
2. Where counter terms and conditions have been offered by the supplier, the same shall not be deemed to have been accepted by us, unless our specific written acceptance thereof is obtained.
3. **Tender Fee: Tenders received without the prescribed Tender Fee will be rejected.**
4. **Clarifications:**
Any technical and commercial questions, information, clarifications, etc. that may be required pertaining to this Tender/enquiry may be obtained from the Purchaser before submitting the tender.
- 4.1 Bids shall be complete in all respects and shall include properly filled in prices, other specifications, schedules, relevant drawings and catalogues as necessary alongwith the bid covering letter, all in duplicate.
5. **QUOTATION:**
Quotation should be submitted **in two parts, i.e. Tender Fee, EMD, Technical Bid & Commercial Terms and conditions (Part-A) and Price Bid (Part-B).** Tender should be submitted in two separate sealed envelopes (in duplicate) superscribing the above tender no., date, due date and brief description of tendered item along with Earnest Money Deposit (EMD) for Rs.20,000/- by way of Demand Draft from a nationalized/scheduled drawn in favour of ***Institute for Plasma Research*** and payable at Ahmedabad should be submitted to the Purchase Officer at the above address latest by 1.00 p.m. on **9th July, 2009.** **Part-A (Technical Bid along with Tender Fee of Rs.200/-, terms and conditions and EMD for Rs.20,000/-)** will be opened on the same day at 3.00 p.m. in the presence of attending tenderers.
- 5.1 Late and delayed quotations will not be considered. IPR will not be responsible for postal delays or any other delays in receipt of quotation. Envelopes received without Tender number, date, due date and short description of item may be rejected. The quoted prices should be firm for a period of 120 days from due date for placing order. IPR is not bound to accept lowest rate/s. IPR reserves the right to place order on one or more parties irrespective of whether he is lowest or not. The scope of supply includes insurance by the Contractor/Supplier.
6. **Specifications:** Material should be offered strictly conforming to our specifications/drawings. Deviation, if any, should be clearly indicated by the supplier in their quotation. The supplier should also indicate the Make/Type number of the materials offered and catalogues, technical literature and samples, wherever necessary should accompany the quotation.
7. **Terms of prices:** Quotation should be submitted on door delivery basis without extra charge wherever possible. For quotations on Ex-Works, Ex-godown basis the

approximate packing and forwarding charges should be indicated by the supplier. In the case of local suppliers, the material is to be delivered at our stores free of charge. Unit rate/s should be valid throughout the validity of purchase order/contract period for addition/deletion purposes. Break-up of price should be furnished. The quoted price should not be subject to price escalation for whatsoever reasons. The quoted price shall be firm, fixed and non-revisable during the validity/extended validity of purchase order/contract.

- 7.1 Prices are required to be quoted according to the units indicated in the tender form. When quotations are given in terms of units other than those specified in the tender form, relationship between the two sets of units must be furnished.
- 7.2 Wherever options are specified in the tender documents, IPR reserves the right to accept any option/s irrespective of whether all the vendors have quoted for all the options or not. The decision of IPR in this regard will be final.
8. Tender should be free from Correction and Erasures. Corrections, if any, must be attested. All amounts shall be indicated both in words as well as in figures. Where there is difference between amounts quoted in words and figures, amount quoted in words shall prevail.
9. IPR shall be under no obligation to accept the lowest or any tender and reserves the right of acceptance of the whole or any part of the tender or portion of the quantity offered and the tenderers shall supply the same at the rates quoted.
10. **Sales Tax etc.:** We have no "C" or "D" form. The percentage of Sales Tax/VAT, surcharge, if applicable, and other levies legally leviable and intended to be claimed should be clearly indicated in the tender. Where this is not done, no claim on these accounts would be admissible later.
- 10.1 **VAT Registration:** You may submit a copy of VAT Registration certificate along with your quotation (if applicable).
- 10.2. **Service Tax:** Wherever Service tax is applicable, it should be mentioned clearly. You may indicate percentage of Service Tax in your quotation.
- 10.3 **Excise Duty:** As per Notification No.10/97-CE (Central Excise) dated 1-3-1997, the Purchaser is entitled for availing Excise Duty exemption at present. Excise Duty Exemption Certificate, wherever applicable, and as per rules will be issued at the appropriate time. Hence Excise Duty should not be included in the BID. However, prevailing percentage of Excise Duty may be indicated.
- 10.4 **Octroi:** Octroi is not applicable in our case.
11. **Delivery Date:** The supplier must indicate the firm delivery date by which the materials will be despatched/delivered by them from the date of our order.
12. **Inspection:** Materials on its arrival at IPR will be inspected by Stores In-charge, and his decision in the matter will be final.
13. **EARNEST MONEY DEPOSIT (EMD):**
The Bidder shall submit interest free Earnest Money Deposit (EMD) for Rs.20,000/- (Rupees Twenty thousand only) by way of Demand Draft from a nationalized/scheduled

bank issued in favour of **"Institute for Plasma Research"** and payable at **Ahmedabad**. **Tender received without EMD will be rejected at the discretion of IPR.**

14.1 EMD of unsuccessful Bidder will be returned after finalizing the Contract/placing Purchase order.

14.2 The EMD shall be forfeited in case the selected Bidder does not start the work within the time limit specified or fail to complete the work within the stipulated delivery period or fail to comply with any of the terms and conditions in the purchase order/contract.

15. Payment:

15.1 10% advance against submission of Bank Guarantee for an equivalent amount from a nationalised Bank. This payment will be made only after signing the contract/Purchase order and submission of Security Deposit.

15.2 10% after approval of major drawings by IPR and on receipt of Bank Guarantee for an equivalent amount from a nationalised bank.

15.3 60% against delivery of material at IPR site, its verification by IPR representative and on receipt of Proforma Invoice in triplicate.

15.4. 20% within 30 days from the date of final acceptance and on receipt of Performance Bank guarantee for 10% of the contract value from a nationalised bank.

Wherever, advance payment is involved, it will be paid only against submission of Bank Guarantee from a Nationalised Bank. Bank Guarantees should be furnished as per IPR format.

16. No correspondence will be entertained within 30 days from the date of receipt of material and bills, whichever is later.

17. Quotation should be valid at least for 120 days from the date of opening of the tender.

18. **Guarantee:** The Stores/material/goods/equipment offered by the bidder should be guaranteed for a minimum period of twelve months, against defective materials, design, workmanship, operation or manufacture. For defects noticed during the Guarantee period, replacement/ rectification should be arranged free of cost within a reasonable period of such notification. In cases where our specifications call for a guarantee period more than 12 months specifically, then such a period shall apply.

19. **Security Deposit:** The successful Bidder will have to furnish to the Purchaser an interest free security deposit for 10% (Ten percent) of the order value in the form of Bank Guarantee of an equivalent amount from a nationalised/scheduled Bank within 15 days from the date of LOI/Purchase order and the said Guarantee should be valid till the goods are accepted by IPR. The Security deposit shall be forfeited in case the selected Bidder does not start the work within the time limit specified or fail to complete the work within the stipulated delivery period or fail to comply with any of the terms and conditions in the purchase order/contract.

20. **Liquidated Damages:** In addition to forfeiting Security Deposit, Liquidated Damages for the delay shall be 1/2% (half percent) of the total order value for the delay of each week in the scheduled time of supply or the scheduled date of final completion for

the work as the case may be, subject to a maximum of 5% (five percent) of total order value. Liquidated Damages will be recovered from the payment due to the supplier.

21. **Performance Bank Guarantee:** The Contractor/Supplier will have to furnish to the Purchaser (IPR) an interest free performance bank guarantee for 10% (Ten percent) of the order value/ contract value by Demand Draft or by way of providing a Bank Guarantee from a Nationalised/Scheduled Bank valid for a period of 12 months/guarantee period mentioned in the order from the date of installation/acceptance for satisfactory performance of the work carried out by the Contractor.
22. The Contractor/Supplier shall at all times indemnify the purchaser against all claims which may be made in respect of the stores/material/goods/equipment for infringement of any right protected by Patent Registration of design or Trade Mark and shall take all risk of accidents or damage, which may cause failure of supply from whatever cause arising and the entire responsibility for sufficiency of all means used by him for the fulfillment of the contract.
23. **BAR/PERT Charts:**
To be provided as per the requirement of Purchaser.
24. **Sub-Contract:** All sub-contractors are required to be appraised and approved by the Purchaser before placement of orders by the Vendor.
25. **Jurisdiction:** The contract/Purchase order shall be governed by the Laws of India for the time being in force. The Courts of Ahmedabad only shall have jurisdiction to deal with and decide any legal or dispute arising out of this contract.
26. **Settlement of disputes:** Any disputes or difference arising out of or in connection with the Contract/Purchase order shall be to the extent possible settled amicably between the parties.

If amicable settlement cannot be reached then all disputed issues shall be settled by arbitration.

27. **Arbitration:** In the event of any dispute or difference arising under this Contract, the matter shall be referred to the Arbitrators one each nominated by the Purchaser and Contractor from their respective organisations. In case the said Arbitrators are not able to settle the dispute by themselves, the matter shall be referred to the Arbitrator mutually nominated by the Purchaser and the Contractor and whose decision will be final and binding on both the parties. The venue of arbitration will be IPR. Subject to as aforesaid the Arbitration Act, 1940 and the rules thereunder and any statutory modification thereof for the time being in force shall be deemed to apply to the Arbitration proceedings under this Contract.
28. **Permits and Licences:** The Contractor shall secure and pay for all permits and licence which he may require to comply with in respect of all laws, ordinances and regulations of the Government or Public Authorities in connection with the performance of his obligations under the Contract. The successful contractor shall be responsible for all damages and shall indemnify and save the Purchaser harmless from and against all claims for damages and liability which may arise due to his failure to comply with what is stated above.

29. **Training:** The successful tenderer shall, if required by the Purchaser, provide facilities for the practical training of Purchaser's engineering or technical personnel for their active association on the manufacturing process throughout the manufacturing period of the Contract/stores, number of such personnel to be mutually agreed upon.
30. **Operation/Instruction Manual:** Where operation/instruction manual is essential to enable the Purchaser to put the stores to proper use, the successful tenderer shall furnish such operation/instruction manual along with the stores.
31. **Test Certificate:** Wherever required, test certificates should be sent along with the despatch documents.
32. **Secrecy:**
- 32.1 All information, drawings, designs and specifications imparted to the bidder/successful contractor shall, at all times, remain the absolute property of the Purchaser, the bidder/successful contractor shall not use them for purposes other than for which they are provided for and shall treat all these documents as confidential. These shall not be reproduced in whole or in part for any other purpose.
- 32.2 The contractor shall use his best endeavours to ensure that such information are not divulged to third parties except where needed for the performance of the contract by the successful bidder with the prior consent of the Purchaser. In such cases, the successful contractor shall ensure and obtain similar obligation of confidence, from third parties in question.
33. **Indemnity:** The Contractor shall warrant and be deemed to have warranted that all stores supplied against this contract are free and clean of infringement of any Patent, copy right or trade mark and shall at all times indemnify the Purchaser against all claims which may be made in respect of the stores for infringement of any right protected by patent. Registration of design or Trade Mark and shall all risk of accidents of damage which may cause a failure of the supply from whatever cause arising and the entire responsibility for the sufficiency of all the means used by him for the fulfilment of the contract.
34. **Counter terms and conditions of Suppliers:** Where counter terms and conditions printed or cyclostyled conditions have been offered by the supplier, the same shall not be deemed to have been accepted by the Purchaser unless specific written acceptance thereof is obtained.
35. **Installation/commissioning/site works:** Wherever these activities are part of scope of work/specifications, Vendor should carryout out the same without any extra cost to IPR.
36. **Free Issue Material (FIM) (If specified in the tender documents):** Successful tenderer will have to furnish in the form a Bank Guarantee or in any other form as called for by the Purchaser towards adequate security for the materials/property provided/issued by the Purchaser as Free Issue Material (FIM) for the due execution of the contract. Successful bidder shall submit Bank Guarantee from a nationalized bank and arrange insurance for the cost of FIM at his expenses.

37. Late/delayed tenders will not be accepted. Incomplete tenders may be rejected at the discretion of IPR.
38. **IPR is not bound to accept the lowest tender. IPR reserves the right to select any vendor at its sole discretion.**
39. **Result of the tenders:** Unsuccessful tenderers will not be informed of the result of their tenders.
40. The Director, IPR reserves the right to accept or reject any quotation/tenders fully or partly without assigning any reason.
41. IPR reserves the right to place order on a single party or to split the order at its sole discretion.

We agree to the above terms and conditions.

Place:

Signature of Bidder with seal

Date:

Note: A copy of our terms and conditions duly signed should accompany your quotation.

