

DRG. NO	CO-ORDINATED BY	▽ 8-25	▽ 1.6-8	▽▽ 0.025-1.6	▽▽▽ < 0.025	REVISION COLUMN	APPROVED BY	DATE	REMARKS	APPROVED BY
						DESCRIPTION				
						ZONE				
						REV				

ASS'Y GROUP:	SIZE	ASS'Y GROUP:	SIZE
A3	A3	A3	A3
ALL DIMENSIONS ARE IN 'mm' UNLESS OTHERWISE STATED			
SCALE	NTS	DATE	
KRR	KRR	21.7.16	
CHECKED	KKM/DRI	REF DRG NO:	
APPROVED		DRG. NO	SST/ICH-TL/A3/16/4028

INSTITUTE FOR PLASMA RESEARCH BHAT, GANDHINAGAR-382 428.	
TITLE	9-3/16" CO-AXIAL TRANSMISSION LINE SECTION DETAILS (ALUMINIUM OUTER CONDUCTOR)
THIRD ANGLE PROJECTION	
REV	REV 00
SHEET	2 OF 3

DRG. NO	CO-ORDINATED BY	▽ 8-25	▽ 1.6-8	▽▽ 0.025-1.6	▽▽▽ < 0.025	REVISION COLUMN	APPROVED BY	DATE	REMARKS	APPROVED BY
						DESCRIPTION				
						ZONE				
						REV				

MACHINING DEVIATIONS FOR NON-TOLERANCED DIMENSIONS			
LENGTH IN mm OF SHORTER SIDE OF ANGLES	UPTO 6-30	30-120	120-315
UPTO 10	10-50	50-120	OVER 120-400
+1°	+0°-30'	+0°-20'	+0°-10'
	+0.1	+0.2	+0.3
	-0.1	-0.2	-0.3
	+0.5		+0.5

LENGTH IN mm OF SHORTER SIDE OF ANGLES	UPTO 6	6-30	30-120	120-315
UPTO 10	10-50	50-120	OVER 120-400	
+1°	+0°-30'	+0°-20'	+0°-10'	
	+0.1	+0.2	+0.3	+0.5
	-0.1	-0.2	-0.3	
	+0.5		+0.5	

LENGTH IN mm OF SHORTER SIDE OF ANGLES	UPTO 6	6-30	30-120	120-315
UPTO 10	10-50	50-120	OVER 120-400	
+1°	+0°-30'	+0°-20'	+0°-10'	
	+0.1	+0.2	+0.3	+0.5
	-0.1	-0.2	-0.3	
	+0.5		+0.5	

DRG. NO	CO-ORDINATED BY	▽ 8-25	▽ 1.6-8	▽▽ 0.025-1.6	▽▽▽ < 0.025	REVISION COLUMN	APPROVED BY	DATE	REMARKS	APPROVED BY
						DESCRIPTION				
						ZONE				
						REV				

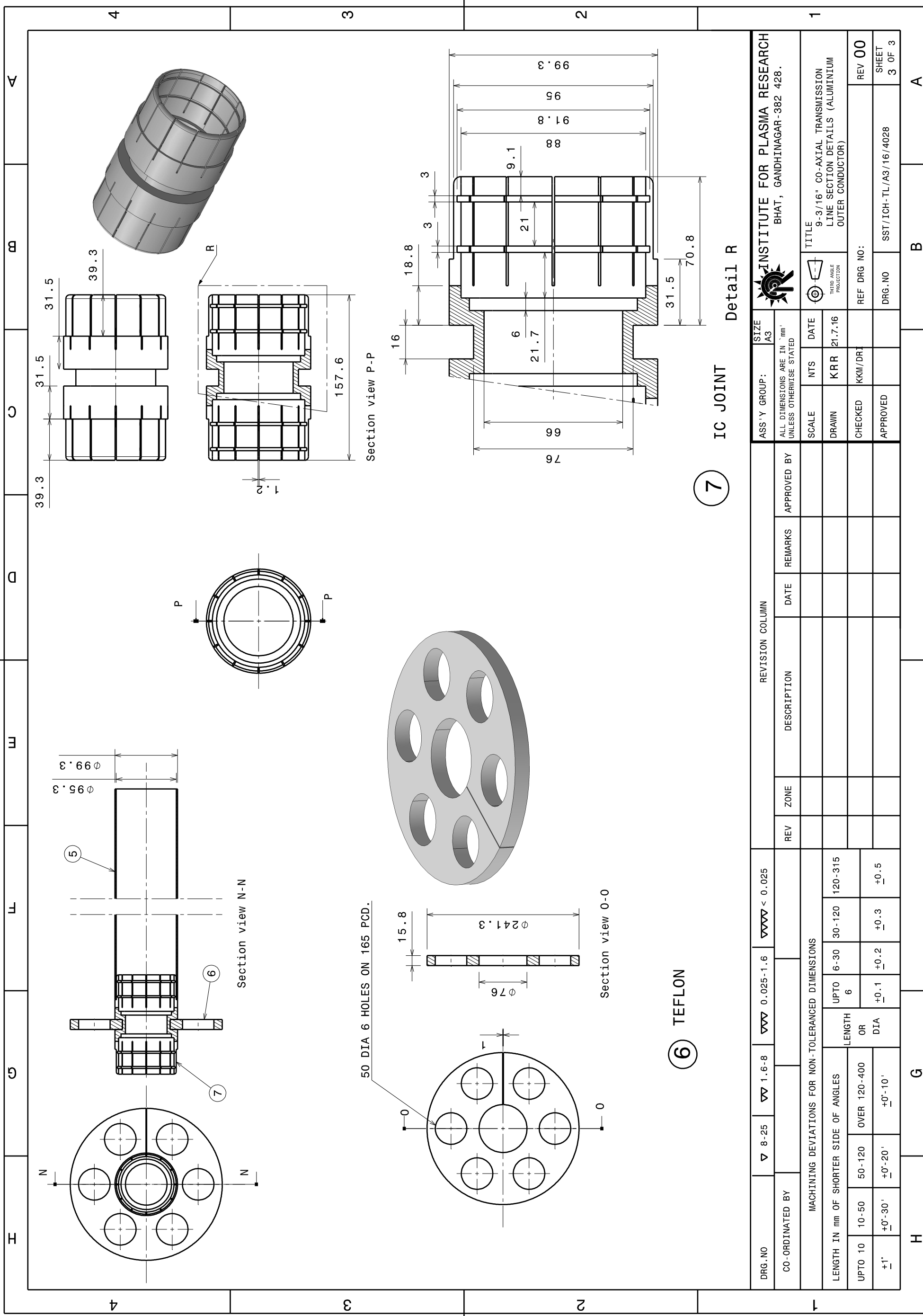

DRG. NO	▽ 8-25	▽ 1.6-8	▽ 0.025-1.6	▽ 0.025 < 0.025	REVISION COLUMN		ASS'Y GROUP:	SIZE	INSTITUTE FOR PLASMA RESEARCH BHAT, GANDHINAGAR-382 428.	
CO-ORDINATED BY					REV	ZONE	APPROVED BY	REMARKS	DATE	TITLE
MACHINING DEVIATIONS FOR NON-TOLERANCED DIMENSIONS										9-3/16" CO-AXIAL TRANSMISSION LINE SECTION DETAILS (ALUMINIUM OUTER CONDUCTOR)
LENGTH IN mm OF SHORTER SIDE OF ANGLES		LENGTH OR DIA		UPTO 6	6-30	30-120	120-315			THIRD ANGLE PROJECTION
UPTO 10	10-50	50-120	OVER 120-400	±0.1	±0.2	±0.3	±0.5			REF DRG NO:
+1'	+0'-30'	+0'-20'	+0'-10'							REV 00
										SHEET 3 OF 3
										DRG. NO SST/ICH-TL/A3/16/4028

7
IC JOINT
Detail R
6
TEFLON

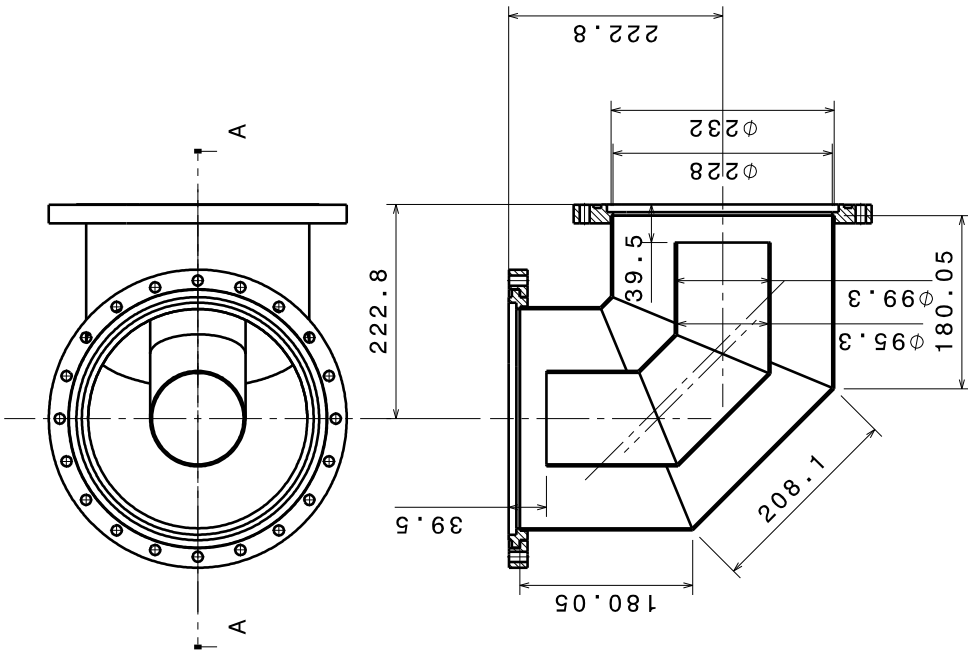
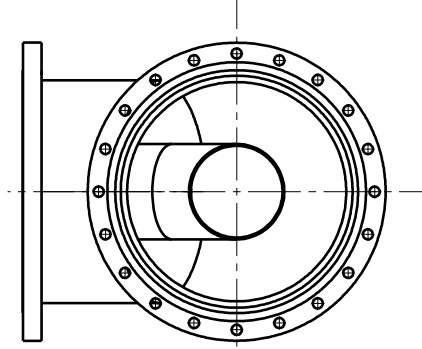
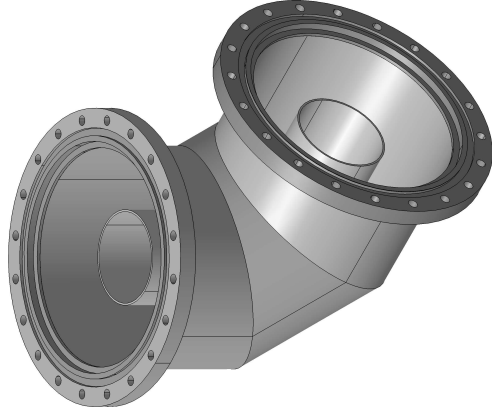

Section view A-A

DRG. NO	CO-ORDINATED BY	▽ 8-25	▽ 1.6-8	▽ 0.025-1.6	▽ < 0.025	REVISION COLUMN	APPROVED BY	SIZE	ASS'Y GROUP:	INSTITUTE FOR PLASMA RESEARCH BHAT, GANDHINAGAR-382 428.
						REMARKS		A3	ALL DIMENSIONS ARE IN "mm" UNLESS OTHERWISE STATED	
						DATE		NTS	SCALE	TITLE
								KRR	DRAWN	ELBOW (NON STANDARD)
								KKM	CHECKED	REF DRG NO:
									APPROVED	DRG. NO
										REV 00
										SHEET
										1 OF 1

MACHINING DEVIATIONS FOR NON-TOLERANCED DIMENSIONS

LENGTH IN mm OF SHORTER SIDE OF ANGLES	LENGTH	UPTO	6-30	30-120	120-315
	OR	6			
	DIA	+0.1	+0.2	+0.3	+0.5
		-0.1	-0.2	-0.3	-0.5