

Top view
Scale: 1:10

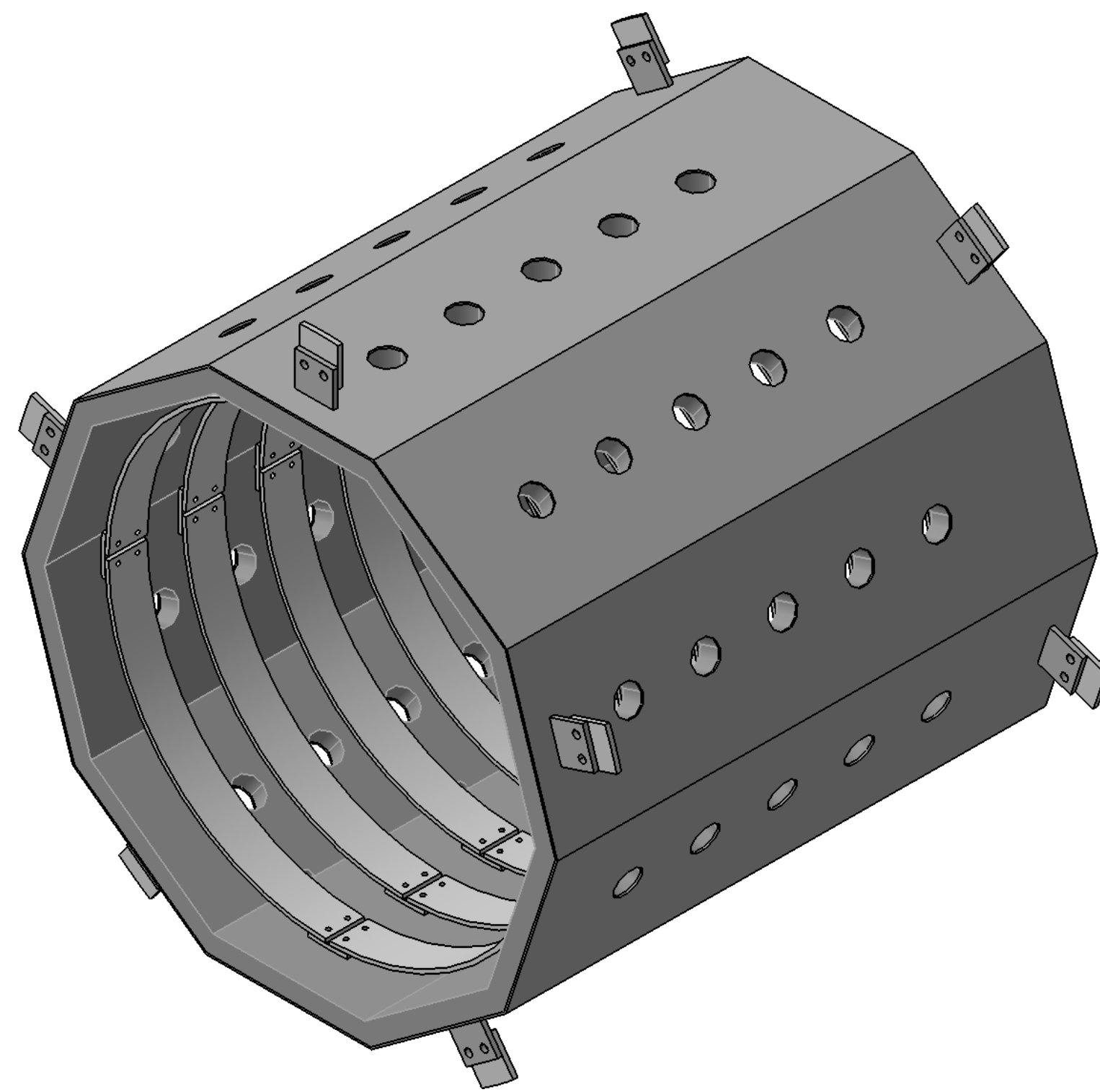

Isometric view
Scale: 1:10

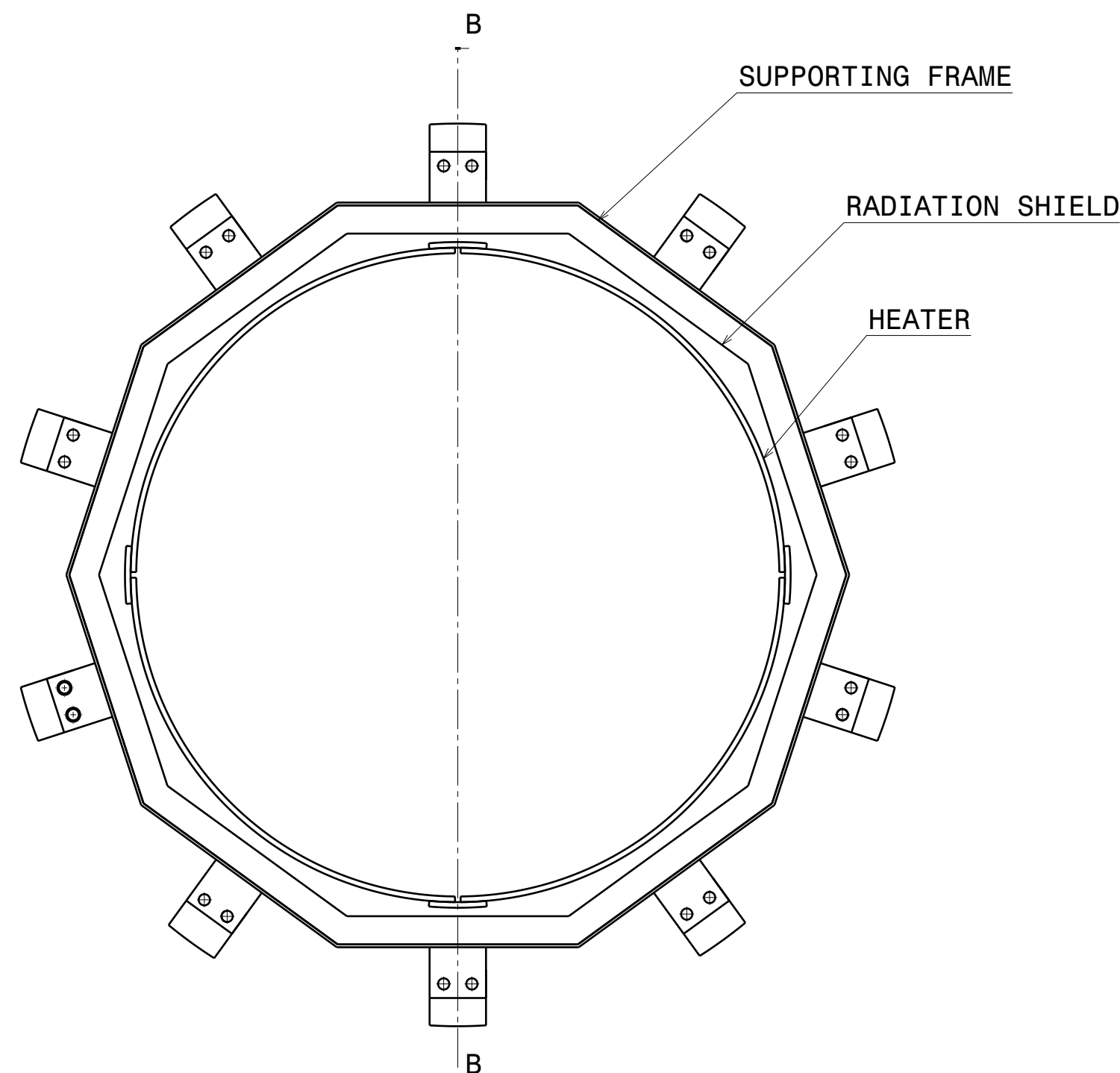
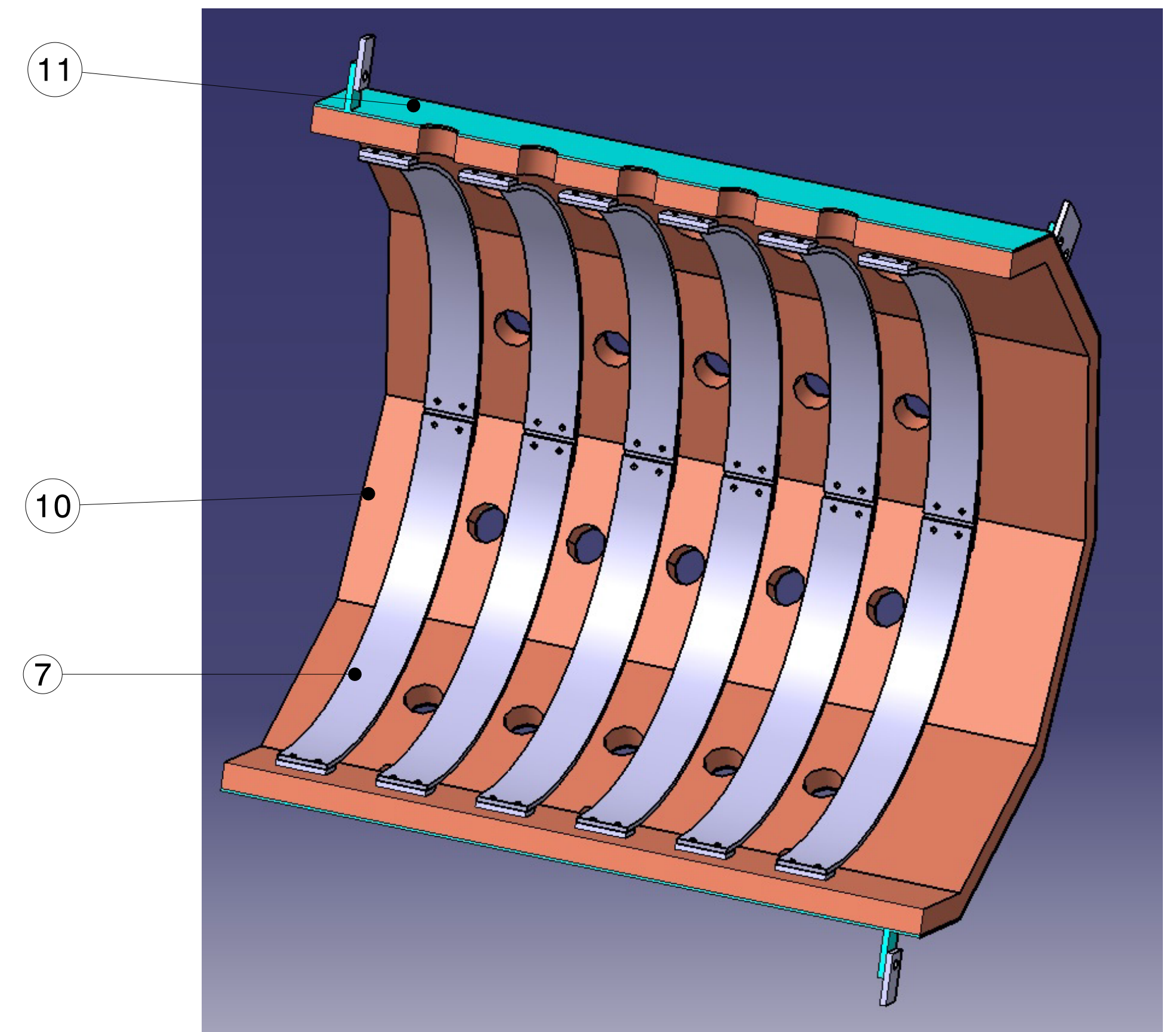

Front view
Scale: 1:10

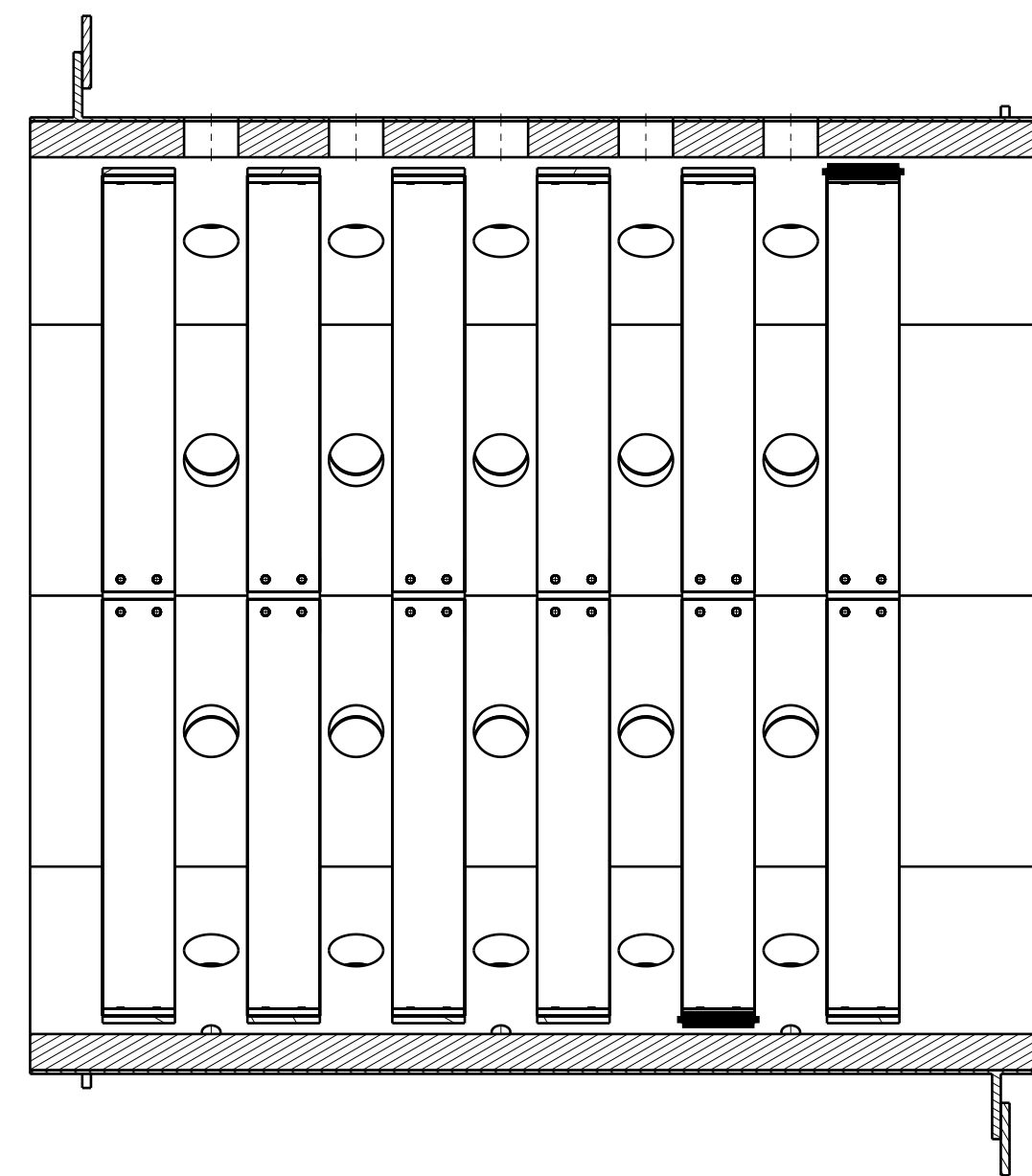

Section view B-B
Scale: 1:10

DRG. NO	▽ 8-25	▽▽ 1.6-8	▽▽▽ 0.025-1.6	▽▽▽▽ < 0.025	REVISION COLUMN					ASS'Y GROUP:	SIZE	INSTITUTE FOR PLASMA RESEARCH			
CO-ORDINATED BY					REV	ZONE	DESCRIPTION	DATE	REMARKS	APPROVED BY	SCALE	DATE	BHAT, GANDHINAGAR-382 428.		
MACHINING DEVIATIONS FOR NON-TOLERANCED DIMENSIONS											TITLE		HEATER ASSY		
LENGTH IN mm OF SHORTER SIDE OF ANGLES				LENGTH OR DIA	UPTO 6	6-30	30-120	120-315			DRAWN	VRP	REF DRG NO: A1		
UPTO 10	10-50	50-120	OVER 120-400		±0.1	±0.2	±0.3	±0.5			DESIGNED	AKSHAY	REV RD		
+1'	+0'-30'	+0'-20'	+0'-10'								APPROVED	AKSHAY	DRG. NO	A1	SHEET 04 OF 05