



प्लाज़्मा अनुसंधान संस्थान
Institute for Plasma Research

Bhat, Gandhinagar 382 428, Gujarat, (India)
भाट, गांधीनगर ३८२ ४२८, गुजरात, (भारत)



निविदा आमंत्रण सूचना (एनआईटी) Notice Inviting Tender (NIT)

निविदा सूचना TENDER NOTICE NO: IPR/TN/PUR/TPT/ET/21-22/043 दिनांकित DATED 14-02-2022

निदेशक, प्लाज़्मा अनुसंधान संस्थान (आईपीआर) के लिए और उनकी ओर से प्रमुख- क्रय एवं भंडार अनुभाग, प्लाज़्मा अनुसंधान संस्थान, क्रेता की निविदा विनिर्देशों के अनुसार अनुबंध के निष्पादन हेतु दो भाग में ऑनलाइन निविदाएं आमंत्रित करते हैं। निविदा आमंत्रण, निविदा शर्तें, अनुबंध की सामान्य शर्तें, अनुबंध की विशेष शर्तें और अनुबंध की अतिरिक्त शर्तें, यदि कोई हो, जो निविदा के अनुसार अनुबंध को नियंत्रित करेगी, संलग्न हैं।

बोली जमा करने के इच्छुक बोलीदाताओं से अनुरोध है कि वे इस दस्तावेज़ की सामग्री को देखें और सुनिश्चित करें कि निविदा आमंत्रण सूचना में निर्दिष्ट नियत तारीख और समय पर या उससे पहले और तकनीकी विनिर्देशों एवं नियमों और शर्तों के अनुसार बोली ऑनलाइन जमा करें और इसके साथ संलग्न प्रपत्र संख्या **e_IPR-PUR-103A** एवं **e_IPR-PUR-103B** डिजिटल रूप से हस्ताक्षरित या स्याही से हस्ताक्षरित वचनपत्र को अपलोड करें।

ऑफलाइन बोलियां हार्ड कॉपी सहित किसी भी रूप में स्वीकार नहीं की जाएगी।

Head-Purchase and Stores Department, Institute for Plasma Research, for and on behalf of Director, Institute for Plasma Research (IPR) invites online tenders IN **TWO PART** for execution of contract in accordance with the purchaser's tender specifications. The invitation to tender, tendering conditions, general conditions of contract, special conditions of contract and additional conditions of contract, if any, which will govern the contract pursuant to the tender are attached.

Bidders interested to submit bid are requested to go through the contents of the NIT and ensure that the bid is submitted online on or before the due date and time indicated in NIT and as per technical specifications and terms and conditions indicated herein and upload digitally signed or ink signed undertaking of Form Nos. **e_IPR-PUR-103A** and **e_IPR-PUR-103B**.

Off line bids including hard copy in any form will not be accepted.

प्रमुख-खरीद अनुभाग / Head-Purchase Section
निदेशक, आईपीआर के लिए और उनकी ओर से / For and on behalf of Director, IPR
(खरीदार / The Purchaser)

संलग्नक: ऊपर के रूप में। / Encl: as above.



निविदा सूचना TENDER NOTICE NO: IPR/TN/PUR/TPT/ET/21-22/043 दिनांकित DATED 14-02-2022

निम्नलिखित के लिए प्रतिष्ठित और योग्य पार्टियों से ई-निविदा विधि के माध्यम से दो भाग में ऑनलाइन निविदा आमंत्रित की जाती है।

Online tender is invited in **TWO PARTS** through e-tendering mode from reputed and eligible parties for the following.

कार्य/वस्तु विवरण / Work/Item Description	Design, Engineering, Assembly, Factory Acceptance Testing, and Supply, Installation, Commissioning and Site Acceptance Testing including Training of High Current Equilibrium Field Power Supply (EFPS) and its spares as per the detailed specifications mentioned in the tender documents
निविदा शुल्क / Tender Fee	Not Applicable
बयाना राशि जमा (ईएमडी) / Earnest Money Deposit (EMD)	Rs. 1,65,000.00 Earnest Money Deposit (EMD) must be in the form of Demand Draft drawn in favour of "Institute for Plasma Research" payable at Gandhinagar and a copy thereof must be uploaded along with quotation. Demand Draft shall be sent to "Head-Purchase Section, Institute for Plasma Research, Bhat, Near Indira Bridge, Gandhinagar-382428 in a sealed envelope super scribing boldly Tender Number and Due date, so as to reach before the due date and time. Offers opened without receipt of EMD before due date and time will be rejected. EMD will be forfeited if the bidder withdraws or amends, impairs or derogates from tender in any respect within the period of validity of the tender. Exemption from Payment of EMD : As per Tender Document
प्रकाशन तिथि / Publishing Date	14-02-2022 at 18:00 Hrs.
दस्तावेज़ डाउनलोड / बिक्री प्रारंभ तिथि / Document Download / Sale Start Date	14-02-2022 at 18:00 Hrs.
स्पष्टीकरण प्रारंभ तिथि / Seek Clarification Start Date	14-02-2022 at 18:00 Hrs.
स्पष्टीकरण समाप्ति तिथि / Seek Clarification End Date	24-02-2022 by 17:00 Hrs.
आईपीआर द्वारा स्पष्टीकरण का जवाब / Response to Clarification by IPR	04-03-2022 by 17:00 Hrs.
बोली जमा करने की तिथि / Bid Submission Start Date	05-03-2022 at 10:00 Hrs.
बोली जमा करने की अंतिम तिथि / Bid Submission Closing Date	29-03-2022 at 13:00 Hrs.
भाग-I (तकनीकी बोली) के ऑनलाइन खुलने का समय और तिथि / Time and Date of online Opening of PART-I (Technical Bid)	30-03-2022 at 14:00 Hrs.
भाग-II के ऑनलाइन खुलने का समय और तिथि (मूल्य बोली) / Time and Date of online Opening of PART-II (Price Bid)	Will be declared later on

कृपया ध्यान दें कि यदि इस निविदा में किसी भी प्रकार का स्पष्टीकरण आवश्यक हो, चाहे वह तकनीकी है या अन्यथा, तो बोलियां जमा करने से पहले स्पष्टीकरण प्राप्त करना होगा।

पात्रता मानदंड और निविदा दस्तावेज के साथ विस्तृत निविदा सूचना वेबसाइट <https://eprocure.gov.in/eprocure/app> पर निःशुल्क देखने और डाउनलोड करने के लिए उपलब्ध है। ई-निविदा प्रक्रिया में भाग लेने के लिए, उपरोक्त ई-निविदा पोर्टल पर पंजीकृत होना अनिवार्य है और डिजिटल हस्ताक्षर प्रमाणपत्र (कक्षा-III) होना आवश्यक है। नए पंजीकरण/निविदा के लिए, बोलीदाता नीचे दिए गए "ऑनलाइन बोली जमा करने हेतु निर्देश" पढ़ सकते हैं।

इस एनआईटी की एक प्रति संस्थान की वेबसाइट www.ipr.res.in पर भी उपलब्ध है।

It may please be noted that any clarifications required in this tender either technical or otherwise shall be carried out before submission of bids.

Detailed tender notice along with Eligibility criteria and Tender Document is available on website <https://eprocure.gov.in/eprocure/app> for free view and downloading. For participating in the e-tendering process, it is mandatory to get registered on the above e-tender portal and required to have Digital Signature Certificate (Class -III). For new registration/ tendering, bidders may go through the “**Instructions for Online Bid Submission**” provided as under.

A copy of this NIT is also available on the Institute’s website www.ipr.res.in .

Instructions for Online Bid Submission

The bidders are required to submit soft copies of their bids electronically on the CPP Portal, using valid Digital Signature Certificates. The instructions given below are meant to assist the bidders in registering on the CPP Portal, prepare their bids in accordance with the requirements and submitting their bids online on the CPP Portal.

More information useful for submitting online bids on the CPP Portal may be obtained at: <https://eprocure.gov.in/eprocure/app>.

REGISTRATION

- 1) Bidders are required to enroll on the e-Procurement module of the Central Public Procurement Portal (URL: <https://eprocure.gov.in/eprocure/app>) by clicking on the link **“Online bidder Enrollment”** on the CPP Portal which is free of charge.
- 2) As part of the enrolment process, the bidders will be required to choose a unique username and assign a password for their accounts.
- 3) Bidders are advised to register their valid email address and mobile numbers as part of the registration process. These would be used for any communication from the CPP Portal.
- 4) Upon enrolment, the bidders will be required to register their valid Digital Signature Certificate (Class III Certificates with signing key usage) issued by any Certifying Authority recognized by CCA India (e.g. Sify / nCode / eMudhra etc.), with their profile.
- 5) Only one valid DSC should be registered by a bidder. Please note that the bidders are responsible to ensure that they do not lend their DSC's to others which may lead to misuse.
- 6) Bidder then logs in to the site through the secured log-in by entering their user ID /password and the password of the DSC / e-Token.

SEARCHING FOR TENDER DOCUMENTS

- 1) There are various search options built in the CPP Portal, to facilitate bidders to search active tenders by several parameters. These parameters could include Tender ID, Organization Name, Location, Date, Value, etc. There is also an option of advanced search for tenders, wherein the bidders may combine a number of search parameters such as Organization Name, Form of Contract, Location, Date, Other keywords etc. to search for a tender published on the CPP Portal.
- 2) Once the bidders have selected the tenders they are interested in, they may download the required documents / tender schedules. These tenders can be moved to the respective 'My Tenders' folder. This would enable the CPP Portal to intimate the bidders through SMS / e-mail in case there is any corrigendum issued to the tender document.
- 3) The bidder should make a note of the unique Tender ID assigned to each tender, in case they want to obtain any clarification / help from the Helpdesk.

PREPARATION OF BIDS

- 1) Bidder should take into account any corrigendum published on the tender document before submitting their bids.
- 2) Please go through the tender advertisement and the tender document carefully to understand the documents required to be submitted as part of the bid. Please note the number of covers in which the bid documents have to be submitted, the number of documents - including the names and content of each of the document that need to be submitted. Any deviations from these may lead to rejection of the bid.
- 3) Bidder, in advance, should get ready the bid documents to be submitted as indicated in the tender document / schedule and generally, they can be in PDF / XLS / RAR / DWF/JPG formats. Bid documents may be scanned with 100 dpi with black and white option which helps in reducing size of the scanned document.
- 4) To avoid the time and effort required in uploading the same set of standard documents which are required to be submitted as a part of every bid, a provision of uploading such standard documents (e.g. PAN card copy, annual reports, auditor certificates etc.) has been provided to the bidders. Bidders can use "My Space" or "Other Important Documents" area available to them to upload such documents. These documents may be directly submitted from the "My Space" area while submitting a bid, and need not be uploaded again and again. This will lead to a reduction in the time required for bid submission process.

Note: *My Documents space is only a repository given to the Bidders to ease the uploading process. If Bidder has uploaded his Documents in My Documents space, this does not automatically ensure these Documents being part of Technical Bid.*

SUBMISSION OF BIDS

- 1) Bidder should log into the site well in advance for bid submission so that they can upload the bid in time i.e. on or before the bid submission time. Bidder will be responsible for any delay due to other issues.
- 2) The bidder has to digitally sign and upload the required bid documents one by one as indicated in the tender document.
- 3) Bidder has to select the payment option as "offline" to pay the tender fee / EMD as applicable and enter details of the instrument.
- 4) Bidder should prepare the EMD as per the instructions specified in the tender document. The original should be posted/couriered/given in person to the concerned official, latest by the last date of bid submission or as specified in the tender documents. The details of the DD/any other accepted instrument, physically sent, should tally with the details available in the scanned copy and the data entered during bid submission time. Otherwise the uploaded bid will be rejected.
- 5) Bidders are requested to note that they should necessarily submit their financial bids in the format provided and no other format is acceptable. If the price bid has been given as a standard BoQ format with the tender document, then the same is to be downloaded and to be filled by all the bidders. Bidders are required to download the BoQ file, open it and complete the white coloured (unprotected) cells with their respective financial quotes and other details (such as name of the bidder). No other cells should be changed. Once the details have been completed, the bidder should save it and submit it online, without changing the filename. If the BoQ file is found to be modified by the bidder, the bid will be rejected.

- 6) The server time (which is displayed on the bidders' dashboard) will be considered as the standard time for referencing the deadlines for submission of the bids by the bidders, opening of bids etc. The bidders should follow this time during bid submission.
- 7) All the documents being submitted by the bidders would be encrypted using PKI encryption techniques to ensure the secrecy of the data. The data entered cannot be viewed by unauthorized persons until the time of bid opening. The confidentiality of the bids is maintained using the secured Socket Layer 128 bit encryption technology. Data storage encryption of sensitive fields is done. Any bid document that is uploaded to the server is subjected to symmetric encryption using a system generated symmetric key. Further this key is subjected to asymmetric encryption using buyers/bid opener's public keys. Overall, the uploaded tender documents become readable only after the tender opening by the authorized bid openers.
- 7) The uploaded tender documents become readable only after the tender opening by the authorized bid openers.
- 8) Upon the successful and timely submission of bids (i.e. after Clicking "Freeze Bid Submission" in the portal), the portal will give a successful bid submission message & a bid summary will be displayed with the bid no. and the date & time of submission of the bid with all other relevant details.
- 9) The bid summary has to be printed and kept as an acknowledgement of the submission of the bid. This acknowledgement may be used as an entry pass for any bid opening meetings.

ASSISTANCE TO BIDDERS

- 1) Any queries relating to the tender document and the terms and conditions contained therein should be addressed to the Tender Inviting Authority for a tender or the relevant contact person indicated in the tender.
- 2) Any queries relating to the process of online bid submission or queries relating to CPP Portal in general may be directed to the 24x7 CPP Portal Helpdesk.

*** * * ***

प्लाज्मा अनुसंधान संस्थान
INSTITUTE FOR PLASMA RESEARCH
(भारत सरकार के परमाणु ऊर्जा विभाग का सहायता प्राप्त संस्थान)
(An Aided Institute of Dept. of Atomic Energy, Govt. of India)
इंदीरा ब्रिज के पास, भाट, गांधीनगर - 382428,
NEAR INDIRA BRIDGE, BHAT, GANDHINAGAR-382428

TWO-PART TENDER

INVITATION TO TENDER

Head-Purchase and Stores Department, Institute for Plasma Research, for and on behalf of Director, Institute for Plasma Research (IPR) invites online tenders IN **TWO PART** for execution of contract in accordance with the purchaser's tender specifications. The invitation to tender, tendering conditions, general conditions of contract, special conditions of contract and additional conditions of contract, if any, which will govern the contract pursuant to the tender are attached.

Bidders interested to submit bid are requested to go through the contents of the NIT and ensure that the bid is submitted online on or before the due date and time indicated in NIT and as per technical specifications and terms and conditions indicated herein and upload digitally signed or ink signed undertaking of Form Nos. **e_IPR-PUR-103A** and **e_IPR-PUR-103B**.

Off line bids including hard copy in any form will not be accepted.

Head-Purchase Section
For and on behalf of Director, IPR
(The Purchaser)

INDEX

Sl.No.	Description	PageNo.
1.	Definitions and Interpretation	3 to 4
2.	Section-A – Invitation to Tender and Tendering Conditions	5 to 19
3.	Section-B – Format for Submission of the Tender	20 to 22
4.	Section-C – General Conditions of Contract and Special Conditions of Contract	23 to 43
5.	Annexure – Format for Bank Guarantee/ Hindrance Register	44 to 57
6.	Section-D – Technical Specifications and Drawing	58

DEFINITIONS AND INTERPRETATION

In the invitation to tender, tendering condition, contract, general conditions of contract and special conditions of contract, unless the context otherwise require the following interpretation shall be valid.

- 1.1 “BID” shall mean the quotation in response to the NIT submitted with EMD, if applicable and within the period mentioned in the NIT.
- 1.2 “BIDDER” means an individual, a firm, a limited liability partnership, a company whether incorporated or not, an association of person or joint venture who has submitted a bid to execute the contract and shall be deemed to include his successors, heirs, executors, administrators and permitted assignees, as the case may be.
- 1.3 “CONSIGNEE” shall mean the authorised representative or officer of the purchaser at the site to whom the stores are required to be delivered in the manner indicated in the contract.
- 1.4 “CONTRACTOR” means a successful bidder with whom a contract agreement has been entered to by the purchaser and shall be deemed to include his successors, heirs, executors, administrators and permitted assignees, as the case may be.
- 1.5 “CONTRACT” or “PURCHASE ORDER” means and comprises of a letter or e- mailor ink signed or digitally signed document issued/sent by the purchaser conveying acceptance of bidder’s/contractor’s bid submitted in response to the NIT within the validity of the bid and any subsequent amendments/alterations thereto made on the basis of mutual agreement.
- 1.6 “DELIVERY DATE” means date of completion of contract excluding warranty period and its obligations as stipulated in the contract.
- 1.7 “DIRECTOR, INSTITUTE FOR PLASMA RESEARCH” means the Director, Institute for Plasma Research, for the time being in the charge of the Purchase and Stores Department, IPR and includes Head- Purchase & Stores Department, Head- Purchase Section, Purchase Officer-II, Purchase Officer-I, Dy. Officer (Purchase) or Assistant Purchase Officer of the said Institute for Plasma Research or any other officer authorized in writing to execute the contract on behalf of the purchaser.
- 1.8 “EARNEST MONEY DEPOSIT (EMD)” means the deposit made in the form and manner specified in the NIT by the participating bidder towards bid security.
- 1.9 “HINDRANCE” means an event resulting in stoppage or delay of work because of the purchaser as recorded by the contractor and authenticated by the purchaser.
- 1.10 “INSPECTOR” or “QUALITY SURVEYOR” means any engineer/officer nominated and deputed by the purchaser or their appointed consultants or quality surveillance agency or any other person authorized by the purchaser from time to time to act as his representative for the purpose of inspection of stores under the contract.
- 1.11 “Notice Inviting Tender (NIT)” means invitation to tender, tendering condition, general conditions of contract, special conditions of contract, additional conditions of contract, if any and any other document mentioned thereto.
- 1.12 “PARTIES” mean the parties to the contract, i.e., the contractor and the purchaser named in the contract.
- 1.13 “PERFORMANCE SECURITY BANK GUARANTEE (PSDBG)” means the deposit made in the form and manner specified in this document by the contractor towards satisfactory performance of the contract till completion of the warranty period.
- 1.14 “PURCHASER” means Director, Institute for Plasma Research for the time being the Head- Purchase and Stores Department or any other authorized officer and includes his successor or assignees.
- 1.15 “STORES” or “PLANT” means the materials, goods, machinery, plants, equipment or parts thereof specified in the contract which the contractor has agreed under the

contract.

- 1.16 “SUB-CONTRACTOR” means any contractor engaged by the contractor with the prior approval of the purchaser in relation to the contract.

TWO PART TENDER SECTION –A
Invitation to Tender and Tendering Conditions

Index

Clause No.	Clause Title	Page No.
1.	INVITATION TO TENDER	7
2.	EMD	7
3.	MANNER AND METHOD FOR SUBMISSION OF BIDS	7
4.	PRICE	8
5.	PAYMENT TERMS	8
6.	CONDITIONAL DISCOUNT	8
7.	VALIDITY OF BID	8
8.	ONE BID PER BIDDER	8
9.	QUALIFYING REQUIREMENTS	8
10.	PRE-BIDMEETING	8
11.	OPENING OF BID	9
12.	DECLARATION OF HOLIDAY	9
13.	EVALUATION OF BIDS	9
14.	QUANTITY	10
15.	INSTALLATION/ERECTION AND COMMISSIONING	10
16.	TEST CERTIFICATE	10
17.	OPERATION/INSTRUCTION MANUAL	10
18.	LEAFLET/CATALOGUE	10
19.	ACCEPTANCE OF BID	11
20.	STATUTORY LEVIES SUCH AS GOODS AND SERVICE TAX	11
21.	CUSTOMS DUTY	11
22.	FLUCTUATION IN THE STATUTORYLEVIES	11
23.	AUTHENTICATION	11
24.	DELIVERY OF STORES FOR CONTRACT IN INDIAN CURRENCY	12
25.	DOCUMENTS TO BE UPLOADED BY INDIAN BIDDER	12
26.	PURCHASE/PRICE PREFERENCE	12
27.	FREE ISSUE MATERIAL	14
28.	BID FROM INDIAN AGENTS ON BEHALF OF FOREIGN CONTRACTOR	15
29.	RESTRICTED INFORMATION CATEGORIES UNDER SECTION 18 OF ATOMIC ENERGY ACT 1962 AND OFFICIAL SECRETS UNDER SECTION 5 OF OFFICIAL SECRETS ACT 1923	15
30.	PROHIBITION AGAINST USE OF THE NAME OF INSTITUTE FOR PLASMA RESEARCH WITHOUT PERMISSION FOR PUBLICITY PURPOSES	15
31.	CONFIDENTIALITY	15
32.	CANVASSING	16
33.	EXPORT LICENCE/EXPORT PERMISSION	16
34.	END USE CERTIFICATE	16
35.	COMPLIANCE WITH SECURITY REQUIREMENTS OF THE PURCHASER	16

36.	COUNTRY OF ORIGIN	16
37.	TERMS AND CONDITIONS OF CONTRACT	16
38.	SAMPLES	17
39.	DETAILS OF BANKERS	17
40.	SUBMISSION OF DRAWINGS	17
41.	SUB-CONTRACTING	17
42.	SHOP/FACTORY EVALUATION, QUALITY SURVELLANCE/ INSPECTION AND SUBMISSION OF PROGRESS REPORT	17
43.	PACKING	18
44.	DEVIATION TO PURCHASER'S SPECIFICATIONS	18
45.	SETTLEMENT OF COMMERCIAL TERMS AND CONDITIONS OF CONTRACT	18
46.	PARTICIPATION OF INDIAN/OVERSEAS BIDDER IN THE TENDER	18
47.	TERMS OF DELIVERY	18
48.	AGENCY COMMISSION	19

1. INVITATION TO TENDER

- 1.1 Head-Purchase and Stores Department, Institute for Plasma Research, for and on behalf of Director, Institute for Plasma Research (IPR), invites bids for execution of contract in accordance with the purchaser's technical specifications. The conditions of contract which will govern the contract pursuant to this tender are available in the NIT. Bidders who are in a position to be submitted online in Two Parts in English language as under:
- 1.2 PART-I (TECHNO-COMMERCIAL): This part of the bid shall include/contain all technical details, technical specifications, drawings submit their bid for the same as per the conditions stipulated in the NIT are requested to submit their bid in a manner and method specified in the NIT.

2 EMD

- 2.1 EMD where called for will have to be submitted by the participating bidder in the form and manner specified in the NIT so as to reach the purchaser at the address mentioned in the NIT on or before the due date and time mentioned in the NIT.
- 2.2 Non receipt of EMD as per Clause no. 2.1 above, will result in rejection of bid without any reference to the bidder, except in cases given under Clause no. 2.3 below.
- 2.3 The following categories of bidders are exempted from submission of EMD:
 - 2.3.1 Bidders having valid registration with Directorate of Purchase and Stores, Department of Atomic Energy;
 - 2.3.2 Micro and Small Enterprises having valid registration with MSME or NSIC or Udyog Aadhaar/ Udyam Aadhar in respect of procurement of goods and services, produced and provided by MSE and startups recognized by Department of Industrial Policy & Promotion (DIPP) are eligible for exemption according to government policies.
 - 2.3.3 Foreign Bidder directly submitting bid (not through their Indian Agent or Indian Counterpart or Indian subsidy) in the currency other than INR.

2.4 Forfeiture of EMD

- 2.4.1 EMD shall be forfeited if the bidder withdraws or amends impairs or derogates from the tender in any respect within the validity of his bid.
- 2.4.2 If the successful bidder fails to furnish the required Security Deposit/ Performance Security Bank Guarantee (PSDBG), the EMD furnished shall be forfeited.
- 2.5 REFUND OF EMD
 - 2.5.1 EMD of unsuccessful bidders will be returned within thirty days after finalization of the tender or after expiry of validity of their bid, whichever is later.
 - 2.5.2 EMD of successful bidders will be returned within thirty days of submission of security deposit as called for in the contract.

3. MANNER AND METHOD FOR SUBMISSION OF BIDS

- 3.1 All bids in response to this invitation to tender shall, literature, reference to earlier supplies of similar stores along with quantity, time required for submission and approval of drawings, manufacturing and delivery period, inspection/testing procedure, itemized list of spares and quantity recommended by the bidder for purchase, term of price, mode and payment terms, mode of despatch, excluding any price details thereof. The bidder shall note that this part of the bid is purely techno-commercial.
- 3.2 The bidder shall not mention the price of the stores or the financial bid in the uploaded document as Part-I of the bid. If Bidder includes prices of the stores or the financial bid in Part-I (Techno-Commercial) of the bid, such bids will be rejected without any notice to the bidder.

- 3.3 Part-II (Price) of the bid shall be submitted strictly online in accordance with the format provided by the Purchaser.
- 3.4 The bidder shall quote cost of essential accessories and spares specified in the price bid format, wherever asked for, to make their bid complete in all respect as per purchaser's technical specifications in Part-II of bid.
- 3.5 If bidder indicates any changes of any nature of the Techno-Commercial bid or upload any technical document indicating changes of any manner/nature of Techno-Commercial bid in Part-II of the bid; such bids will be rejected without any notice to the bidder.
- 3.6 The bidder will co-relate the prices of stores in Part-II of the bid with the description of the stores indicated in Part-I (Techno-Commercial) of the bid in order to enable the purchaser to identify the prices with the corresponding stores in Part-I (Techno-Commercial) of the bid.
- 3.7 Both Part-I (Techno-Commercial) and Part-II (Price) of the bid should be submitted together online on or before the time and date specified for its submission in the NIT.

4 PRICE

- 4.1 The prices quoted must be FIRM during the currency of the contract.

5 PAYMENT TERMS

- 5.1 Standard payment terms for supplies made against this tender will be as indicated in Form no. IPR-P-100.

6 CONDITIONAL DISCOUNT

- 6.1 In case the bidder offers any conditional discount with regard to acceptance of the bid within a specific period or specific payment terms, delivery date, quantity, etc., the purchaser will not take into consideration such conditional discount while evaluating the bid.

7 VALIDITY OF BIDS

- 7.1 Bids shall be kept valid for acceptance for a period as mentioned in the NIT. Bids with shorter validity period shall be rejected without any notice to the bidder.

8 ONE BID PER BIDDER

- 8.1 Each bidder shall submit only one bid for a tender. All bids of the bidder who submits more than one bid for the same tender; will be rejected without any notice to the bidder.
- 8.2 If a bidder submits bid on behalf of two principals or if the bidder and his sister concern participates in the same tender or such instances where participation of any bidder leads to conflict of interest, the bid will be rejected without any notice to the bidder.

9 QUALIFYING REQUIREMENTS

- 9.1 The bidder is required to upload all supporting documents/information on the e- tender portal necessary for establishing their qualification as mentioned in the NIT.

10 PRE-BID MEETING

- 10.1 A pre-bid meeting for providing clarifications to the bidder will be held on-line unless otherwise specified, on the date and time mentioned in the NIT. Bidders participating in this tender and who have enrolled in our e-tender portal (<https://eprocure.gov.in/eprocure/app>) can login and upload their queries. Bidders are requested to upload their queries both Technical and Commercial well in advance at the eTender portal within the due date and time prescribed for the submission of queries. Queries/clarification/information sought in any other manner shall be ignored. Any modification to the tender, which may become necessary as a result of the pre-bid meeting, will be uploaded on the e-tender portal against the particular Tender ID. Bidders are requested to update themselves by visiting e-tender portal

<https://eprocure.gov.in/eprocure/app> frequently. It may be noted that no queries will be entertained after the date and time for submission of queries. Therefore, bidders in their own interest should participate in the pre-bid meeting to understand the tendered requirements.

11 OPENING OF BID

- 11.1 Unless otherwise preponed or postponed, bids will be opened online in two stages on the date and time indicated in the NIT.
- 11.2 Part-I (Techno-Commercial) of the bid will be opened at the first stage on the due date and time indicated for opening in this NIT.
- 11.3 All the bidders who have submitted bids within the due date and time specified for its submission can view the list of bidders who have participated in the tender online after opening of the tender.
- 11.4 After completion of the evaluation of the Part-I (Techno-Commercial) of the bid, the due date and time for opening of Part-II (Price) of the bid shall be intimated to the bidders whose bids are found technically acceptable to the purchaser. The due date and time will also be displayed on the e-tender portal.
- 11.5 Part-II (Price) of the bid, whose Part-I of the bid is found to be techno-commercially acceptable to the Purchaser can be viewed.

12 DECLARATION OF HOLIDAY

- 12.1 If the date(s) specified for opening of the bid is/are declared as holidays due to any administrative reasons, then the due date(s) for receipt/opening of bid will get postponed to the next working day.

13 EVALUATION OF BIDS

13.1 TECHNICAL CLARIFICATION

After opening the Part – I (Techno-Commercial) of the bid, if it becomes necessary for the technical authorities/user department of the purchaser to seek clarifications from the bidder, the same will be sought for from the bidder by the Purchase Section. In such an event, the bidder shall furnish all techno-commercial information/clarification to the Purchase Section to reach them on or before the due date and time fixed by the Purchaser. If the techno-commercial clarifications/details sought for by the Purchase Section from the bidder do not reach them on or before the due date and time fixed for its receipt, such bid will be liable for rejection at the discretion of the purchaser without any further notice. The bidder shall not, however, furnish a new bid at this stage. A new bid at this stage will be rejected by the purchaser.

- 13.2 Evaluation of bids shall be based on technical specification attached with tender and on the basis of total landed cost considering taxes/duties as applicable without any concession/exemption.

13.3 DETERMINATION OF TOTAL LANDED COST FOR COMPARISON (AIR/SEA SHIPMENTS)

- 13.3.1 The following will be the loading for air/sea freight

13.3.1.1 FCA/FOB price + air/sea freight @10% of FCA/FOB price = CFR price

13.3.1.2 CFR price + insurance @ 1% of CFR price= CIF price

13.3.1.3 CIF price + taxes & duties as applicable =DDP

13.3.1.4 [DDP + clearing charges @ 1% of CIF price + inland freight @ 1% of CIF price] x exchange rate = total landed cost in INR

Exchange rate means Purchase price of the quoted currency as intimated by State Bank of India and as applicable on the date of opening of bid.

13.4 CAPACITY AND FINANCIAL CAPABILITY

- 13.4.1 In case it is found that the bidder does not possess the requisite infrastructure, capacity, capability and their financial capability satisfactory or not meeting the qualification criteria indicated in the NIT or not complied with warranty obligations; such bids are liable to be rejected by the purchaser during evaluation of bid.

13.5 PAST PERFORMANCE

- 13.5.1 In case the past performance of the bidder is not found to be satisfactory with regard to quality, delivery date, warranty obligation and compliance of terms and conditions of the contract, their bid is liable to be rejected by the purchaser during evaluation of bid.

13.6 POST SUPPLY INSPECTION

- 13.6.1 The bidder should clearly mention requirement of post supply inspection in the bid. The purchaser reserves the right to deny access to the contractor or its representative or any third party to the Stores supplied by the contractor after its supply. Bids which are not complying with this post supply inspection requirement are liable to be rejected by the purchaser during evaluation of bid.

14 QUANTITY

- 14.1 Quantities mentioned in the NIT are approximate. One or more of the items of the stores tendered or a portion of any one or more of the items of such stores may be accepted by the purchaser. A bidder shall be bound to supply to the purchaser such an item or items or such portion or portions of one or more of the items as may be accepted by the purchaser.

15 INSTALLATION/ERECTION AND COMMISSIONING

- 15.1 Wherever, the purchaser's NIT includes installation and commissioning or supervision of installation and commissioning or erection and commissioning of the stores by the bidder, the bidder must clearly and separately quote the prices for the supply of the Stores and the charges for installation and commissioning or its supervision or erection and commissioning, as the case may be.
- 15.2 The bidder should not include charges towards installation and commissioning or its supervision or erection and commissioning in the price of the stores offered. In case of failure to quote separately, purchaser will deduct taxes as applicable on full contract value.
- 15.3 In respect of contracts involving installation and commissioning or its supervision or erection and commissioning by the contractor where identifiable charges for the same have been quoted, the contractor shall bear the tax liability as per the rates prevailing at the time of undertaking the job in accordance with the relevant Act/Laws in force in India.
- 15.4 When the scope of the contract includes installation and commissioning, it shall be the sole responsibility of the contractor to undertake the installation and commissioning as and when called for, by the purchaser.

16 TEST CERTIFICATE

- 16.1 Wherever the tests and test certificates are required by the purchaser, test shall be conducted and test certificate shall be furnished by the contractor as per the requirement of technical specification.

17 OPERATION/INSTRUCTION MANUAL:

- 17.1 In respect of stores where instruction/operation manual is essential to enable the purchaser to put the stores into proper use, the contractor shall furnish such instruction/operation manual in English language along with the stores free of cost.

18 LEAFLET/CATALOGUE:

- 18.1 Bidder shall upload all necessary catalogues/drawings technical literature data sheet as are considered essential for full and correct evaluation of their technical bid. The bids are liable to be ignored if this condition is not complied with.

19 ACCEPTANCE OF BID

- 19.1 The purchaser shall be under no obligation to accept the lowest or any other bid and shall be entitled to accept or reject any bid in part or full without assigning any reasons whatsoever.
- 19.2 The purchaser also reserves the right to reject the bid, which is not in conformity with the conditions contained in this document or the instructions to bidders attached in NIT, if any including non-acceptance of submission of securities as called for in the NIT.

Clauses 20.0 to 24.0 are applicable only for bids quoted in INDIAN RUPEES.

20 STATUTORY LEVIES SUCH AS GOODS AND SERVICE TAX

- 20.1 Statutory levies at rate applicable for the purchaser within original delivery date will be admitted by the purchaser.

20.2 GOODS AND SERVICE TAX

- 20.2.1 The purchaser is entitled for GST at the concessional rate as per notifications issued by the Government, as amended from time to time, in respect of purchases made for certain stores.

- 20.3 Decision to avail concession/exemption, in each case will be at the sole discretion of the purchaser. Wherever concession/exemption is mentioned in the contract, purchaser will provide the relevant certificate to the contractor. It would be the responsibility of the contractor to obtain the same from the purchaser before effecting the delivery of stores failing which the excess tax paid by the contractor shall not be reimbursed by the purchaser.

21 CUSTOMS DUTY

- 21.1 In case an Indian bidder submits a bid for supply of outrightly imported stores in Indian Rupees, they should quote price for free and safe delivery of stores at destination. The name of their foreign contractor and country of origin shall also be indicated. However, purchaser will neither provide any certificate for availing concession/exemption from payment of customs duty nor will reimburse the same.
- 21.2 Bids on High Sea sales basis will not be considered.

22 FLUCTUATION IN THE STATUTORY LEVIES

- 22.1 Unless otherwise specifically agreed to in terms of the contract, the purchaser shall not be liable for any claim on account of fresh imposition and /or increase in statutory levies on raw materials and/or components used directly in the manufacture of the contracted stores, taking place during the pendency of the contract. However, any reduction in statutory levies on these raw materials and/or components must be passed on to the purchaser.

23 AUTHENTICATION

- 23.1 The person digitally signing and uploading the bid or any other document in respect of the tender on behalf of the bidder shall be deemed to warrant that he has the authority to do so and the action will be binding on the bidder. The bidder shall indemnify the purchaser from any consequences arising thereof.
- 23.2 Overseas bidder should also refer Clause No. 46.1 of this Section for details on obtaining digital signature certificate valid in India.
- 23.3 If, on enquiry or later on, it appears that the persons so signing had no authority to do so, the purchaser may, without prejudice to other civil and criminal remedies, cancel the contract and hold the bidder and signatory liable jointly and severally for all costs

and damages.

24 DELIVERY OF STORES FOR CONTRACT IN INDIAN CURRENCY

- 24.1 Bidder should note that the bid is liable for rejection by the purchaser unless the bidder offers to complete the contract within the delivery date specified by the purchaser. The prices quoted by the bidder should include all charges involved for direct and safe delivery of the stores to the place of delivery indicated by the purchaser. Purchaser will neither undertake responsibility for transit insurance nor pay for it separately. The bidder shall quote as per the delivery terms stated in the NIT.
- 24.2 The stores shall neither be despatched under 'purchaser's risk' nor consigned to 'self', but only to the consignee indicated in the contract. Non-adherence to this condition shall make the contractor liable to bear all consequential penalties/expenses such as demurrage, wharfage, etc. which the purchaser may incur.
- 24.3 The consignee will, as soon as possible, but not later than thirty days from the date of arrival of stores at destination notify the contractor of any loss or damage to the stores that may have occurred during transit to enable the contractor to repair/rectify the defects/damages or replace the stores as is appropriate, free of all charges. In case it is desired by the contractor for returning of the stores to them, all expenses towards transportation, etc. will be borne by the contractor and the contractor will also furnish bank guarantee as per format in Annexure for the payment already made by the purchaser to the contractor on this account, if any.

25. DOCUMENTS TO BE UPLOADED BY INDIAN BIDDER

- 25.1 Indian bidders are required to upload a copy of the PAN card/letter and copy of the factory registration/licence or shop establishment certificate/GSTIN etc. as applicable with the bid.

26. PURCHASE/PRICE PREFERENCE

- 26.1 Purchase/price preference to industries will be given as per the policy of the Government of India in force at the time of opening of bids provided their bid is in compliance with the conditions of the policy.

26.2. PURCHASE PREFERENCE FOR MICRO & SMALL ENTERPRISES (MSE's):

- 26.2.1. Benefits, as prescribed by the MSME Policy of the Government of India shall be provided to MSE vendors registered as manufacturers for the goods procured or for the service providers for services to this Department. The procuring Entity reserves its option to give price preference to Micro and Small Industries in comparison to the large-scale industries as per policies of the Government from time to time.

26.3. MAKE IN INDIA:

- 26.3.1. As defined under the Public Procurement (Preference to Make in India), order 2017, Revised order dated: 16/09/2020 or as being revised from time to time, in procurement of goods or services in respect of which the Nodal Ministry/Department has communicated, that there is sufficient local capacity and local competition, only "Class-I local supplier", as defined under the said order, shall be eligible to bid irrespective of purchase value.
- 26.3.2. Only "Class-I local supplier" and "Class-II local supplier", as defined under the above said order, shall be eligible to bid in procurements under taken by this Directorate, except where the mode of procurement is by issue of Global Tender Enquiry. The bidding supplier shall indicate the percentage of local content for the item being offered in their bid.
- 26.3.3. Where the procurement is by issue of Global Tender enquiry, Non local suppliers, shall also be eligible to bid along with "Class-I local suppliers and Class-II local suppliers". Suppliers/bidders offering imported products will fall under the category of Non-local suppliers.

- 263.4. Subject to the provisions of the above said order, and to any specific instructions issued by the Nodal Ministry or in pursuance of the said order, purchase preference shall be given to “Class-I local Suppliers” in procurements under taken by this Directorate, in the manner specified there in the order.
- 263.5. The bidders along with their bid/tender shall be required to provide a self-declaration certificate of the local content (where the procurement value is Rs.10 Crore or less) for the item offered and their status as Class-I/Class-II/Non-Local supplier and their eligibility to participate in the tender as per Annexure-XI failing which bid will be rejected. In cases of procurement for a value in excess of Rs.10 crores, the “Class-I local supplier”/“Class-II local supplier” shall be required to provide a certificate from the statutory auditor or cost auditor of the company (in the case of companies) or from a practicing cost accountant or practicing chartered accountant (in respect of Contractors other than companies) giving the percentage of local content.
- 263.6. Self-declaration certificate should quantify the percentage of local content of the offered product only. It should also indicate the location. However, claiming the services such as transportation, insurance, installation & commissioning, training and after sale service support like AMC/CMC etc., shall not be considered as local content as per OM N.P-45021/102/2019-BE-II-Part(1)(E-50310) dated:4/03/2021 issued by Ministry of Commerce and Industry, DPIIT.
- 263.7. False declarations/violation of this order terms shall be deemed to be breach of code of integrity resulting in debarment of the firm for a period up to 2 years. Under such circumstances, the supplier shall not be considered for any preferences as proposed in the order.
- 263.8. Wherever the bids are received without accompanying the above said requisite certificate such offers shall be treated as incomplete and not considered.
- 263.9. Bidders/contractors are divided into three categories based on Local Content (The total value of the item procured (excluding net domestic indirect taxes) minus the value of imported content in the item (including all customs duties) as a proportion of the total value, in percent):
- 263.9.1. Class-I local supplier is with local content equal to or more than as prescribed by the Nodal Ministry/ NIT, if prescribed, for the item being procured or 50% whichever is higher.
- 263.9.2. Class-II Local supplier is with local content more than as prescribed by the Nodal Ministry/NIT, if prescribed, for the item being procured or 20% whichever is higher, but less than that applicable for class-I local supplier.
- 263.9.3. Non-local supplier is with local content less than that applicable to class-II local supplier, as stated above.

Note: Where the estimated value of the procurement is less than Rs.5 Lakhs (or as being amended by the competent authority from time to time) is exempted from the provisions of the above Make in India policy as stated therein the order.

26.4. GLOBAL TENDER:

The currency of the price quoted in the bid can be in foreign currencies, in addition to the Indian rupees, except for expenditure incurred in India (Including incidental services rendered in India and agency commission, if any) which should be stated in Indian Rupees.

26.5. ELIGIBILITY OF BIDDERS FROM SPECIFIED COUNTRIES:

- 265.1. Orders issued by the Government of India restricting procurement from bidders of certain countries which shares a land border with India shall apply to this procurement.
- 265.2. Any bidder from a country which shares a land border with India (<https://mea.gov.in/india-and-neighnours.htm>), excluding countries as listed in the website of Ministry of External Affairs (<https://meadashbaord.gov.in/indicators/92>), to which the Government of India has extended lines of credit or in which the Government of India is engaged in development projects – hereinafter called “Restricted

countries) shall be eligible to bid in this tender only if the bidder is registered (<https://dipp.gov.in/sites/default/files/Revised-Application-Format-for-Registration-of-Bidders-15Oct2020.pdf>) with the Registration committee constituted by the Department for promotion of Industry and Internal Trade(DPIIT) . The bidders shall enclose valid registration certificate along with their offer. Wherever the bids are received without accompanying the above said requisite certificate such offers shall be treated as incomplete and not considered.

Furthermore, every bidder participating against this Department tender shall invariably enclose along with the Bid, a self-declared undertaking “Annexure to Bid Form: Eligibility Declarations” (Annexure-XII), failing which Bid will be rejected.

27. FREE ISSUE MATERIAL (FIM): (This clause shall apply only to contract for supply of fabricated stores with purchaser's FIM)

27.1 Wherever the contract envisage supply of FIM by the purchaser to the Indian contractor for fabrication of the stores, such FIM shall be safeguarded by a Bank Guarantee as per format in Annexure or insurance policy to be provided by the Indian contractor at his own cost for the full value of FIM and the insurance policy or Bank Guarantee shall cover, the following risks specifically and shall be valid for six months beyond the delivery date.

27.2 RISKS TO BE COVERED: Any loss or damage to the FIM due to fire, theft, riot, burglary, strike, civil commotion, terrorist act, natural calamities, etc. and any loss or damage arising out of any other causes such as other objects falling on FIM while in his possession including transit period.

Insured by:	(Name of the contractor)
Beneficiary:	Head- Purchase and Stores Department, Institute for Plasma Research, (On behalf of Director, Institute for Plasma Research), Near Indira Bridge, Bhat Gandhinagar-382428
Amount for which insurance Policy/Bank Guarantee has to be Furnished	The amount will be indicated in the respective contract.

27.3 Notwithstanding the insurance cover taken out by the Indian contractor as above, the contractor shall indemnify the purchaser and keep the purchaser indemnified to the extent of the value of FIM to be issued till such time the entire contract is executed and proper account for the FIM is rendered and the left over/surplus and scrap items are returned to the purchaser. The contractor shall not utilize the FIM for any job other than the one contracted out in this case and also not indulge in any act, commission or omission or negligence which may cause/result in any loss/damage to the purchaser and in which case, the contractor shall be liable to pay full compensation to the purchaser to the extent of damage/loss as assessed by the purchaser. The decision of the purchaser will be final and accepted by the contractor. The contractor shall be responsible for the safety of the FIM after these are received by him and all through the period during which the materials remain in his possession/control/custody. The FIM on receipt at the contractor's works shall be inspected by him for ensuring safe and correct receipt of FIM. The contractor shall report the discrepancies, if any, to the purchaser immediately but not later than five working days from the date of receipt of FIM. The contractor shall take all necessary precautions against any loss, deterioration, damage or destruction of the FIM from whatever cause arising whilst the said FIM remain in his possession/custody or control. The FIM shall be inspected periodically at regular intervals by the contractor for ensuring safe preservation and storage and maintain inspection report. The contractor shall also not mix up the FIM in question with any other goods and shall render true and proper account of the FIM actually used and return balance/remaining/unused FIM on hand and scrap within the delivery date. If it is not possible to return balance remaining unused FIM on hand and scrap within

the delivery date, the contractor hereby authorizes the purchaser to deduct the difference between the cost of FIM supplied and the cost of FIM actually used from the amount payable to the contractor. The contractor shall also indemnify the purchaser to compensate the difference in cost between the actual replacement cost of FIM lost/damaged and the claim settled in favour of the purchaser by the insurance company. The decision of the purchaser, as to whether the contractor has caused any loss, destruction, damage or deterioration of FIM while in his possession, custody or control from whatever cause arising and also on the quantum of damage suffered by the purchaser, shall be final and binding upon the contractor.

27.4 Wherever the contract envisage supply of FIM by the purchaser to the foreign contractor for fabrication of the stores, such FIM shall be safeguarded by a Bank Guarantee to be provided by the contractor at his own cost for the full value of FIM and the Bank Guarantee shall cover, the risks mentioned in Clause 27.2 and 27.3 above and shall be valid for six months beyond the delivery date.

27.5 FIM will be issued to the contractor only after receipt of the insurance policy/Bank Guarantee from the contractor. The contractor shall arrange collection of the FIM from the purchaser's premises and safe transportation of the same to his premises at his risk and cost.

28. BIDS FROM INDIAN AGENTS ON BEHALF OF FOREIGN CONTRACTOR

28.1 Indian agents are allowed to quote on behalf of only one foreign contractor against this tender.

28.2 In case the bid is submitted by an Indian bidder or Indian agent on behalf of their foreign contractor, following documents is required to be uploaded with the bid, failing which, bid is liable to be rejected without further notice to the bidder.

28.2.1 Copy of the agency agreement between the principal and the Indian agent showing the percentage or the quantum of agency commission payable and included in the price quoted and a valid letter of authority from the principal authorizing the Indian agent to submit the bid on their behalf should be uploaded with the bid. The agency agreement shall be valid on the date of opening of bid and shall remain valid throughout the currency of contract.

28.2.2 The type and nature of after sales services to be rendered by the Indian agent.

29. RESTRICTED INFORMATION CATEGORIES UNDER SECTION 18 OF ATOMIC ENERGY ACT, 1962 AND OFFICIAL SECRETS UNDER SECTION 5 OF THE OFFICIAL SECRETS ACT, 1923

29.1 Any contravention of the above-mentioned provisions by the bidder or contractor or its sub-contractor, consultant, adviser or its employees will invite penal consequences under the aforesaid legislations as amended from time to time.

30. PROHIBITION AGAINST USE OF THE NAME OF INSTITUTE FOR PLASMA RESEARCH WITHOUT PERMISSION FOR PUBLICITY PURPOSES

30.1 The bidder or contractor or its sub-contractor, consultant, adviser or its employees or any one claiming on behalf of them shall not use the name of Institute for Plasma Research for any publicity purpose through any public media like Press, Radio, T.V. or Internet without the prior written approval of the purchaser.

31. CONFIDENTIALITY

31.1 The drawings, specifications, prototypes, samples or any other correspondence/details/information provided by the purchaser relating to the tender or the contract shall be kept confidential by the bidder or contractor as the case may be, and should not be disclosed or passed on to any other person/firm without prior written consent of the purchaser. This clause shall also apply to anyone claiming through bidder or contractor, i.e., the sub-contractors, consultants, advisers of the contractor and its employees, etc.

32. CANVASSING

32.1 Canvassing in any form with regard to this tender will lead to rejection of the bid

33. EXPORT LICENCE/EXPORT PERMISSION

33.1 It is entirely the responsibility of the bidder or contractor to obtain export permission/license/authorisation for stores of foreign origin as required from the respective Government before arranging shipment.

33.2 Establishment of letter of credit or similar payment instruments shall be done only after receipt of export license/export permission, if applicable the contract/ purchase order.

33.3 The contractor shall indemnify the purchaser against any consequences in respect of any end-use declaration they/their overseas principals may furnish to the government/government agencies of the country of origin of the Stores, while seeking export permission/license. It is, therefore, necessary that the contractor offering stores from foreign countries shall have thorough knowledge of export contract regulations prevalent in those countries.

33.4 Post supply inspection by the contractor or his representative or any third party at purchaser’s site, contrary to the terms and conditions of purchaser's contract shall not be permitted.

34. END USE CERTIFICATE

34.1 Whenever an End Use Certificate is desired by the bidder, the same shall be clearly mentioned in the bid and the purchaser shall provide an End Use Certificate as per the format given below. The purchaser will not provide any other document/declaration in this regard.

<p><u>END USE STATEMENT</u></p> <p><i>“We hereby certify that the item/s i.e..... being procured from M/s..... against our Purchase Order No. IPR/..... dated will be used for.....</i></p> <p><i>We also certify that the item/s will not be used in designing, developing, fabricating or testing of any chemical, biological, nuclear, or weapons of mass destruction or activities related to it.</i></p> <p><i>It is further certified that we will not re-export the Item/s prior to obtaining permission from the concerned authorities as may be required”.</i></p>
--

35. COMPLIANCE WITH THE SECURITY REQUIREMENTS OF THE PURCHASER

35.1 The contractor shall strictly comply with the security rules and regulations of the purchaser in force and shall complete the required formalities including verification from police and any other authority and obtain necessary prior permission for entry into the purchaser’s premises, wherever authorized by the purchaser.

36. COUNTRY OF ORIGIN

36.1 Wherever the tenders are for imported stores, the country of origin of the stores must be clearly specified in the bid.

37. TERMS AND CONDITIONS OF THE CONTRACT

37.1 It must be clearly understood that any contract concluded pursuant to this NIT shall be governed by the General, Special and Additional Conditions of the Contract as contained in the NIT. Bidder must, therefore, take special care to go through the NIT. It should also be realized that the General Conditions of Contract, Special Conditions of Contract and Additional Conditions of Contract, if any, contained in NIT is binding and

the bidder is willing to execute the contract as per the purchaser's terms and conditions of contract.

38. SAMPLES

- 38.1 Samples of the offered stores, if called for in the NIT, shall be submitted by the bidder free of all charges indicating purchaser's tender number so as to reach the authorized person on or before the last date of submission of bid and without any obligation of the purchaser as regards acceptance/approval, safe custody or safe- return thereof. Each sample submitted must be clearly labeled with the bidder's name and address and tender number. In the event of non-acceptance of the bid, the bidder shall collect the samples at his own expenses within fifteen days from the date of intimation. In case bidder fails to collect such samples within the designated time, the same will be disposed-off by the purchaser and no claim will be entertained from the bidder for the same. Bids without samples shall be rejected, where these were asked for submission in the NIT.
- 38.2 If the bidder submits the sample with his bid; the same shall not be considered to be part of the stores unless it has been specifically stated in the NIT.
- 38.3 In case supplies of tendered goods are required as per sample available with the purchaser, the purchaser will provide the sample on submission of a deposit as indicated in the NIT, as a standard for bidding and supply, on request. The contractor may send their representative at an address indicated in the NIT for collection of the sample. The purchaser will not be responsible for any delay in receipt/collection of sample by the bidder. It will be the responsibility of the bidder to return the sample without any damage/deterioration as indicated in the NIT. In the event of non-return of the sample in the desired condition within fifteen days from the date of intimation, the purchaser reserves the right to forfeit the deposit of the bidder.

39. DETAILS OF BANKERS

- 39.1 The bidder shall submit along with Part-I (Techno-Commercial Part) of the bid account details, IFSC code, the name and address of his bankers for refund of EMD and payment as applicable.

40. SUBMISSION OF DRAWINGS

- 40.1 The bidder shall upload all drawings pertaining to the stores, wherever called for in the NIT along with Part-I (Techno-Commercial) of bid for correct understanding and evaluation of the bid. Bidder's drawing will form part of the contract only after these are approved by the purchaser.

41. SUB-CONTRACTING

- 41.1 The contractor in the event of his bid being accepted by the purchaser shall not assign/sublet or delegate the contract or any part thereof without the prior written consent of the purchaser. The contractor may without the purchaser's consent purchase such parts, accessories, raw materials etc. from any of the leading and reputed manufacturers in case he does not normally manufacture such items provided these items comply with the technical specifications. However, the contractor shall be solely responsible for the satisfactory execution of the contract irrespective of the fact whether a part or a portion of the contract has been assigned or sublet by him to a sub-contractor even when such sub-contracting has been done with the prior written consent of the purchaser.

42. SHOP/FACTORY EVALUATION, QUALITY SURVEILLANCE/ INSPECTION AND SUBMISSION OF PROGRESS REPORT

- 42.1 The purchaser or his technical authorities may at his option and prior to evaluation of the bid depute his inspector or any quality surveillance agency to the factory/workshop/premises of the bidder or contractor to assess and establish the manufacturing capability etc. of the bidder. Similarly, the purchaser may also depute his inspector/quality surveillance agency for inspection of the stores during the various stages of manufacture. In such an event the contractor shall allow reasonable facility

and free access to his factory/work/records to the inspector for the purpose of inspection or for ascertaining the progress of contract.

43. PACKING

43.1 Contractor shall note that packing for shipment shall be in accordance with the instructions outlined in this NIT. Each package shall be limited to the size and weights that are permissible under the existing air, sea or road cargo limits, as the case may be. Even when no packing specification is included in the NIT, it will be contractor's responsibility to provide appropriate packing depending upon the nature of the supply and the transportation and handling hazards. The stores shall be so packed and protected as not to suffer deterioration, damage or breakage during shipment and storage in a tropical climate.

43.2 Each package shall be properly labeled to indicate the type and quantity of stores it contains, the purchase order number, its dimensions and weight and any other necessary data to identify the stores and relate it to the contract.

43.3 In case of damage of the stores due to inadequate/poor packaging, the purchaser's decision will be final and binding on the contractor. In such cases, the contractor will arrange replacement of such stores at his risk and cost within the delivery date on receipt of written intimation from the purchaser.

44. DEVIATIONS TO PURCHASER'S TECHNICAL SPECIFICATIONS

44.1 If any deviation or substitution from the technical specifications contained in Section "D" to this tender document is involved, such details should be clearly indicated by the bidder in Part-I (Techno-Commercial) and it should be uploaded as an Annexure to Part-I (Techno-commercial) of the bid as otherwise it shall be an admission on the part of the bidder that he will supply the stores as specified by the purchaser. Part-II (Price) should be submitted online in the bid format provided by the purchaser.

45. SETTLEMENT OF COMMERCIAL TERMS AND CONDITIONS OF CONTRACT

45.1 The commercial terms and conditions of sale/contract stipulated in Part-I (Techno-commercial) of the bid submitted by the bidder should be in line with the purchaser's terms and conditions stipulated in the NIT. In case, the bidder does not accept the purchaser's terms and conditions stipulated in the NIT, their bid will be outrightly rejected. The bidder should note that the authority to settle the commercial terms and conditions of contract rests only with the purchaser and any agreement/understanding reached between the bidder and any other authorities will not be valid and binding.

46. PARTICIPATION OF INDIAN/OVERSEAS BIDDER IN THE TENDER

46.1 Indian and overseas bidder can participate in the tender by using digital signature certificate/encryption certificate issued by any licenced certifying authority authorized by Controller of Certifying Authority, India.

47. TERMS OF DELIVERY

47.1 Indian bidders quoting in INR should quote only for safe delivery of stores to the purchaser's consignee.

47.2 Overseas/foreign/Indian bidder quoting in foreign currency should quote on the following INCOTERM basis:-

47.2.1 For air shipment: **FCA at the specified 'Gateway Airport'**, as per list given

47.2.1.1 List of Gateway Airports

Sl. No.	Country	Gateway Airport
1	Argentina	Buenos Aires
2	Australia	Melbourne
3	Austria	Vienna
4	Belgium	Antwerp
5	Canada	Toronto / Montreal
6	China	Beijing
7	Czech Republic	Prague
8	Denmark	Copenhagen
9	Finland	Helsinki
10	France	Paris
11	Germany	Frankfurt
12	Hong Kong	Hong Kong
13	Ireland	Dublin
14	Italy	Rome
15	Japan	Tokyo / Osaka
16	Netherlands	Amsterdam
17	Norway	Oslo
18	Poland	Warsaw
19	Russia	Moscow
20	Singapore	Singapore
21	South Africa	Johannesburg
22	South Korea	Seoul
23	Spain	Barcelona/Madrid
24	Sweden	Stockholm
25	Switzerland	Zurich
26	United Kingdom	London
27	U.S.A.	JFK

47.2.1.2 Since the purchaser has authorized consolidation agents, they will arrange for air-freight from the respective Gateway Airport.

47.2 For sea shipment: FOB (Port of despatch)

47.2.2.1 The price quoted shall include the cost of the stores, packing charges, inland transportation charges up to the port of despatch, i.e., major sea ports in country of despatch and loading of the stores on to the ship. The name of the sea port from where the shipment will be made shall also be indicated.

48. AGENCY COMMISSION

48.1 Agency commission payable to the contractor's agents in India, if any, shall be included in the price. Name and address of Indian agent and the percentage of commission payable to them and included in the price shall be clearly indicated. The commission will be paid in INR directly by the purchaser to the Indian agents after final acceptance. The manner and method of payment of agency commission is indicated in the General Conditions of Contract/Special Conditions of Contract.

SECTION 'B'
FORMAT FOR SUBMISSION OF
TENDER

DECLARATION

Part-I (Techno-commercial) of Tender No: _____ Dated _____

Bidder's Bid No: _____ Dated _____

From,
M/S _____

To,
Head- Purchase and Stores Department
Institute for Plasma Research
Near Indira Bridge; Bhat
Gandhinagar-382428 (INDIA),

Dear Sir,

I / We have gone through the tendering conditions pertaining to the Two Part Tender and General Conditions of Contracts and Special Conditions of Contracts, if any

- a. I/we hereby agree to execute the contract in accordance with the tender specifications incorporated in Section "D" of the tender document also agree to abide by General Conditions of Contract, Special Conditions of Contract contained in Section "C" of the Tender Document and Additional Conditions of Contract, if any.
- b. Purchaser will be at liberty to accept any one or more of the items of Stores offered by us and I/We shall be bound to supply the stores as may be specified in the contract.
- c. I/We hereby agree to keep our above mentioned bid valid for the period mentioned in the NIT.
- d. Deviations to technical specifications contained in Section "D" of the tender documents are detailed in Annexure "A" of the tender form while deviations proposed to General Conditions of Contract and Additional Conditions of Contract, if any, are detailed in Annexure "B" to this tender.
- e. Prices applicable are indicated in the price bid format of the tender.
- f. I/We are also uploading herewith all the leaflet/ catalogue, etc. pertaining to the stores offered.
- g. If I/We withdraw or modify the bid during the period of validity of if I/We are awarded the contract and I/We fail to submit a PSDBG before the deadline mentioned in the contract, I/We shall be suspended for a period of one year from being eligible to submit bids for contracts with Institute for Plasma Research.

Yours faithfully
Bidder
(Digitally signed or ink signed)

DECLARATION

Part-II (Price) of Tender No: _____ **Dated:** _____
Bidder's Bid No: _____ **Dated** _____

From,
M/S _____

To,
Head- Purchase and Stores Department
Institute for Plasma Research
Near Indira Bridge; Bhat
Gandhinagar-382428 (INDIA),

Dear Sir,

In response to purchaser's invitation to tender and as per the tender and contract conditions, the prices applicable for the contract as contained in Part-I (Techno-commercial) of our tender are indicated in the price bid format of the tender.

I/We hereby agree to keep our above mentioned bid valid for the period mentioned in the NIT.

If I/We withdraw or modify the bid during the period of validity or if I/we are awarded the contract and I/We fail to submit a PSDBG before the deadline mentioned in the contract, I/we shall be suspended for a period of one year from being eligible to submit bids for contracts with Institute for Plasma Research.

Yours faithfully
Bidder
(Digitally signed or ink signed)

SECTION 'C'

**General Conditions of Contract and
Special Conditions of Contract**

INSTITUTE FOR PLASMA RESEARCH
(An Aided Institute of Dept. of Atomic Energy, Govt. of India)
NEAR INDIRA BRIDGE, BHAT
GANDHINAGAR-382428

General Conditions of Contract
and Special Conditions of
Contract

Index

Clause No.	Clause Title	Page No.
GENERAL CONDITIONS OF CONTRACT (Part-A)		
	PREAMBLE	26
1.	AUTHORITY OF PERSONS SIGNING THE CONTRACT ON BEHALF OF THE CONTRACTOR	26
2.	DRAWINGS AND SPECIFICATIONS	26
3.	GENERAL WARRANTY	27
4.	ALTERATION	27
5.	PACKING	27
6.	INSPECTION	27
7.	SECURITIES	28
8.	DELIVERY DATE – TIME IS THE ESSENCE OF CONTRACT.	29
9.	ADVANCE INTIMATION OF DELIVERY	30
10.	EXTENSION OF DELIVERY DATE	30
11.	FORECLOSURE OF CONTRACT OR REDUCTION IN SCOPE OF WORK BEFORE DELIVERY DATE	30
12.	INSPECTOR'S AUTHORITY	31
13.	RECTIFICATION AND REPLACEMENT OF DEFECTIVE STORES	31
14.	CONSEQUENCE OF REJECTION	32
15.	RECOVERY OF SUMS DUE	32
16.	LIEN IN RESPECT OF OTHER CONTRACT	33
17.	WARRANTY	33
18.	PERMITS AND LICENSES	33
19.	PATENT INDEMNIFICATION	33
20.	MODE AND DOCUMENTATION FOR PAYMENT	34
21.	STATUTORY DEDUCTIONS	34
22.	AGENCY COMMISSION	35
23.	MARKING	35
24.	CODE OF INTEGRITY	35
25.	LAW GOVERNING THE CONTRACT	37
26.	JURISDICTION	37
27.	SETTLEMENT OF DISPUTES	37
28.	ARBITRATION	37
29.	TRANSFER OF OWNERSHIP	37
30.	EXERCISING THE RIGHTS AND POWERS OF THE PURCHASER	38
31.	TERMINATION OF CONTRACT	38

Clause No.	Clause Title	Page No.
------------	--------------	----------

SPECIAL CONDITIONS OF CONTRACT (Part-B)

1.	RESPONSIBILITY FOR COMPLETENESS	39
2.	FINAL TEST	39
3.	REJECTION OF DEFECTIVE STORES/PLANT	39
4.	WARRANTY	39
5.	ERECTION AND COMMISSIONING	40
6.	TRAINING	41
7.	PAYMENT TERMS	41
8.	FORCE MAJEURE	42
9.	LIMITATIONS	43
10.	HINDRANCES	43

PREAMBLE

While the conditions contained in General Conditions of Contract will apply to all types of contracts, whereas General Conditions of Contract as well as Special Conditions of Contract will apply to contracts for design/manufacture, supply installation and commissioning of the plant/machinery/equipment/instrument as the case may be.

PART-A

GENERAL CONDITIONS OF CONTRACT

1. AUTHORITY OF PERSON SIGNING THE CONTRACT ON BEHALF OF THE CONTRACTOR

The person/s signing or digitally signing the bid or any other document in respect of the bid or contract on behalf of the bidder or contractor shall be deemed to warrant that he has the authority to bind the contractor.

2. DRAWINGS AND SPECIFICATIONS

The drawings and specifications are intended to be complementary and to provide for and comprise everything necessary for the completion of the contract. Any material shown on the drawing even if not particularly described in specifications or vice versa is to be supplied by the contractors if it were both shown and specified.

In case any discrepancy is noted in the drawings and/or specifications and any interpretation of the same be required, the matter shall be referred to the purchaser for clarification which shall be binding upon the contractor. Otherwise, the contractor shall assume responsibility for the interpretation of the drawings and specifications including his sub-contractor(s).

In case any difference or dispute arises with regard to the true intent and meaning of drawings or specification or in case any portion of the same be obscure or capable of more than one interpretation, the same shall be decided by the purchaser whose decision shall be final.

All lettering on the drawings is to be considered as part of the specification and contract. In all cases figured dimensions are to be followed rather than those indicated by scale. Large scale drawings will take precedence over smaller scale drawings.

The contractor's drawings shall, when approved by the purchaser, be deemed to be included in the list of drawings which form part of the contract. The contractor shall not proceed with fabrication until all drawings associated therewith have been duly approved by the purchaser in writing or as specified in the NIT.

The contractor shall be responsible for and shall pay for any alterations of the stores and shall indemnify the purchaser for any consequential expenditure incurred by the purchaser due to any discrepancies, errors, omissions etc. what so ever in the drawings or other specifications supplied by him whether such drawings etc. whatsoever have been approved by the purchaser or not, provided that such discrepancies, errors or omissions etc. is not due to inaccurate information or specifications furnished to the contractor on behalf of the purchaser.

3. GENERAL WARRANTY

The stores supplied by the contractor under the contract shall be of best quality and workmanship. The contractor shall execute the contract in accordance with the technical specifications unless any deviation has been expressly specified in the contract and any amendments agreed thereto in writing.

The contractor's bid to execute the contract in accordance with the technical specifications shall be deemed to be an admission on his part that he has fully acquainted himself with the details thereof and no claim shall lie against the purchaser on the ground that the contractor did not examine or acquaint himself fully with the technical specifications of the contract.

4. ALTERATIONS

The purchaser may, in exceptional circumstances, make changes in the drawings, technical specifications and issue additional instructions without altering the contract in any manner provided that the changes will be as far as possible not materially alter the character and scope of the contract.

It shall be lawful for the parties to the contract to alter by mutual consent at any time, the drawings and technical specifications of stores. The stores to be supplied shall be in accordance with such altered drawings and technical specifications from the dates specified by the parties; provided that if any such alterations involve increase or decrease in the cost of or in the period required for production, a revision of the contract price and/or the delivery date shall be made by mutual agreement in respect of the stores to which the alteration applies. In all other respects, the contract shall remain unaltered.

5. PACKING

The contractor shall pack the stores at his own cost sufficiently and properly for transit by air/sea/road as the case may be so as to ensure their being free from loss or damage while in transit to the ultimate destination specified in the contract.

Unless otherwise provided in the contract all containers (including packing cases, boxes, tins, drums and wrappings etc.) in which the stores are supplied by the contractor shall be considered as property of the purchaser and their cost as having been included in the contract price.

6. INSPECTION

The contractor shall be responsible for and perform all testing required in accordance with the contract and technical specifications included therewith.

The purchaser may at his option depute inspector(s) for inspection of the stores at contractor's works. The contractor shall facilitate such inspection of stores manufactured by him.

The contractor shall give notice of readiness for inspection to the inspector (deputed under Clause 6.2 above) so that the inspector can be present at the requisite time. The contractor shall dispatch stores only after inspector deputed by the purchaser has issued shipping release.

The contractor shall allow reasonable facility and free access to his work/factory/premises and records to the inspector for the purpose of inspection or for ascertaining the progress of work related to ordered stores under the contract.

The contractor shall provide the drawings, tooling, gauges, instruments etc. and extend all the help required for carrying out the inspection work.

The contractor shall produce an inspection plan to the purchaser's satisfaction notifying check points on the plan. The final inspection shall be conducted as per the approved quality assurance plan.

The contractor shall not supply or deliver the stores unless and until a shipping release or an authorisation for despatch is obtained in the format provided by the purchaser if Pre Despatch Inspection is mentioned in Technical specification. Failure to comply with this instruction as applicable will not only make the contractor ineligible for payment for the supply, but also hold the contractor liable for payment of compensation to the purchaser due to delay in clearance of the stores from the carriers.

If the contractor dispatches stores without obtaining shipping release or authority to dispatch, he will not be entitled to get any payment for such supply, in addition the contractor will pay damages for delayed clearance of the stores from the carrier.

7. SECURITIES

The contractor shall provide the securities in favour of the purchaser in the form of bank guarantees as stated in sub-clauses indicated herein below for a period covering sixty days beyond the completion period mentioned in the contract or such extended period as may be agreed to between the parties, subject to the following conditions:

7.1. Applicable for contracts in INDIAN RUPEE

The bank guarantee should be executed by State Bank of India or any Indian nationalized banker Scheduled Banks as appearing in the second schedule of Reserve Bank of India (other than co-operative and Grameen Banks), on a non-judicial stamp paper of appropriate value as per the purchaser's format.

7.2. Applicable for contracts other than in INDIAN RUPEE having condition for submission of Bank Guarantee by Foreign Contractor.

The bank guarantee should be executed by State Bank of India or any Indian Nationalized banker Scheduled Banks as appearing in the second schedule of Reserve Bank of India (other than co-operative and Grameen Banks) or any Foreign Bank acceptable to the Purchaser. Bank Guarantee drawn from any bank in India shall be on a non-judicial stamp paper of appropriate value whereas Bank Guarantee drawn from Overseas Bank shall be on the Letter Head of the Bank, as per the purchaser's format.

The bank guarantees shall be submitted as per the format available in Annexure.

All bank guarantees are to be sent by the bankers of the contractor directly to the purchaser.

Where the contractor fails to complete the contract within the delivery

date, the contractor shall apply to the purchaser for extension of delivery date of the contract. Such application shall be made before the last date of completion of the contract. The purchaser may at his discretion extend delivery date of the stores under such condition as he may deem fit. All Bank Guarantees so submitted shall also be suitable extended well in time, failing which the purchaser shall have the right to invoke the bank guarantee without prejudice to the terms and conditions of the contract. The contractor shall not supply the material unless the purchaser has extended delivery date of stores in writing

7.3. PERFORMANCE SECURITIES

Contractor shall furnish Performance Security Deposit in the form of bank guarantee for three percent of the value of the contract, including statutory levies, for due performance of the said contract till expiry of warranty period, as per Annexure-I within thirty days from the date of issue of contract in case of Indian Rupee contracts or within thirty days from the date of receipt of Export License by the contractor from respective Government in case of contracts having currency other than Indian Rupee, as the case may be. The Bank Guarantee shall be valid till satisfactory completion of the contract till expiry of warranty period pursuant to General Conditions of Contract, plus a claim period of sixty days from the completion period mentioned in the contract for lodging of claims, if any.

If the contractor fails to provide PSDBG as stated herein above, within thirty days from the date of issue of contract such failure shall constitute a breach of contract and action as deemed fit may be initiated against the contractor.

In case, the contractor fails to fulfill the obligations under the contract; the purchaser shall have the right to invoke and appropriate the PSDBG. This right shall be in addition to and without prejudice to the rights of the purchaser under the terms and conditions of contract

7.4. BANK GUARANTEE FOR FREE ISSUE MATERIAL

Bank Guarantee for Free Issue Material (hereinafter referred to as FIM) (for fabrication of stores at contractor's works outside purchaser's site): The contractor shall submit a Bank Guarantee as per Annexure VIII as applicable to the extent of full value of FIM as security of free issue material issued to the contract or till such time the entire contract is executed and proper account for the FIM is rendered by the contractor to the Purchaser.

8. DELIVERY DATE – TIME IS THE ESSENCE OF CONTRACT

The delivery date stipulated in the contract shall be deemed to be the essence of the contract and the contract must be completed not later than date(s) stipulated therein.

PHASED DELIVERY/MILESTONE

Where the contract envisages phased delivery or completion of milestone, the delivery date for each phase or milestone shall be deemed to be the essence of contract.

Acceptance beyond the delivery date is at the sole discretion of the purchaser and subject to Section C Part A Clause No.10. The contract shall be deemed to be terminated after the expiry of delivery date and subjected to Section C Part A Clause 32.2 and Clause 32.3.

9. ADVANCE INTIMATION OF DELIVERY

Contractors shall send advance intimation to the consignee preferably by e-mail regarding intended delivery of material at least five days prior to the date of delivery of stores to the consignee so as to make proper arrangements for receipt of the stores. If delivery of stores is being carried out by a vehicle, the contractor shall confirm that the driver carries, as on date of delivery, all valid documents, viz., driving license, vehicle registration documents, insurance cover for the vehicle etc. in addition to delivery challan in duplicate along with other documents if any, as per the contract. Failure to carry the valid documents by the driver will result in denial of entry of vehicle inside consignee’s premises and the consignee will not be responsible for any consequences thereof.

10. EXTENSION OF DELIVERY DATE

The purchaser will without prejudice to the other rights of the purchaser invoke the following damages for extension of delivery date:

Sl. No.	Delivery Period	Liquidated Damages, Rate per Week	Maximum Amount of Liquidated Damages
1.	Delivery period (as originally stipulated) not exceeding one year	@0.5% of the value of the stores, per week or part thereof	5% of the value of stores.
2.	Delivery period (as originally stipulated) exceeding one year but not exceeding two years.	@ 0.25% of the value of the stores, per week or part thereof.	5% of the value of stores.
3.	Delivery period (as originally stipulated) exceeding two years	@ 0.1% of the value of the stores, per week or part thereof.	5% of the value of stores.

Delivery Period means “The time from date of release of the contract to the date of delivery of stores”.

However, the payment of liquidated damages shall not in any way absolve the contractor from any of its obligations and liabilities under the contract.

11. FORECLOSURE OF CONTRACT OR REDUCTION IN SCOPE OF WORK BEFORE DELIVERY DATE

If before the delivery date, the purchaser may at its discretion, decide to abandon or reduce the scope of the contract for any reason whatsoever and does not require the whole or part of the contract to be executed, the purchaser shall give notice of four weeks in writing to that effect to the contractor and the contractor shall act accordingly in the matter. The

contractor shall have no claim for any payment of compensation or otherwise whatsoever, on account of any profit or advantage which he might have derived from the execution of the contract in full but which he did not derive in consequence of the foreclosure of the whole or part of the contract.

The contractor shall be paid at contract rates, full amount for part of contract executed and delivered to the purchaser. In addition, a reasonable amount as certified by the purchaser will be paid to the contractor for the stores hereunder mentioned which could not be utilized in the contract to the full extent in view of the foreclosure.

Purchaser shall have the option to take over contractor's materials or any part thereof either bought for execution of the contract or of which the contractor is legally bound to accept delivery from its contractor (for use in the contract). For materials taken over or to be taken over by purchaser, cost of such materials as calculated by purchaser shall be paid. The cost shall, however, take into account purchase price, cost of transportation and deterioration or damage which may have been caused to materials whilst in the custody of the contractor.

If any materials supplied by purchaser are rendered surplus, the same except normal wastage shall be returned by the contractor to purchaser at rates not exceeding those at which these were originally issued, less allowance for any deterioration or damage which may have been caused whilst the materials were in the custody of the contractor. In addition, cost of transporting of such materials from contractor's site to consignee, if so required by purchaser, shall be paid.

The contractor shall, if required by the purchaser, furnish books of accounts and other relevant documents and evidence as may be necessary to enable the purchaser to certify the reasonable amount payable under Clause 11.2 above.

The reasonable amount payable for the stores shall not be in excess of the cost of the contract remaining incomplete on the date of closure, i.e. total stipulated cost excluding taxes of the contract as per accepted tender less the cost of stores actually delivered and also less the cost of contractor's materials at site taken over by the purchaser as above. Provided always that against any payments due to the contractor on this account or otherwise, the purchaser shall be entitled to recover or be credited with any outstanding balances due from the contractor for advance paid in respect of this contract and any other sums which on the date of termination were recoverable by the purchaser from the contractor under the terms of this contract.

12. INSPECTOR'S AUTHORITY

The inspector, wherever deputed by the purchaser under relevant Clauses of the Contract shall have the power:

to certify that the stores are not in accordance with the specifications provided in the contract owing to the adoption of any unsatisfactory method of manufacture, before any Stores or parts thereof are inspected.

to reject any Stores submitted for inspection or part thereof as not being in accordance with the technical specification provided in the contract.

13. RECTIFICATION AND REPLACEMENT OF DEFECTIVE STORES

If the inspector finds that the contractor has executed any unsound or imperfect work, the inspector shall notify such defects to the contractor in writing with thirty days from the date of delivery and the contractor on receiving the details of such defects or deficiency, shall at his own expenses, within seven days or otherwise within such time as may be mutually agreed upon between the parties as reasonably necessary, proceed to alter, reconstruct or remanufacture the stores to the requisite standard and technical specifications according to the contract.

In case repair/replacement of defective/rejected stores is necessary and becomes essential to return the stores, to the contractor, where full or part payment has already been made by the purchaser, the contractor shall submit bank guarantee for the value of stores so found defective/rejected as per Annexure-V or VI as may be applicable and valid till receipt and acceptance of repaired/replaced/entire stores within fifteen days of intimation. However, the contractor will not be absolved from his responsibility as specified under Section C Part-A Clause No.8.

14. CONSEQUENCE OF REJECTION

If the stores are rejected by the inspector or consignee at the destination and the contractor fails to make satisfactory supplies within the delivery date, then the purchaser may:

Allow the contractor to submit for inspection of fresh stores in replacement of the rejected, within extended delivery period subject to Section C Part A Clause No. 10, the contractor bearing the cost of freight on such replacement without being entitled to any extra payment on that account. OR

Purchaser may take recourse to Section C Part A Clause 8.4.

15. RECOVERY OF SUMS DUE

Whenever any claim for payment arises out of or under this contract against the contractor, the purchaser shall be entitled to recover the sum by appropriating, in part or whole, the security deposited by the contractor or any payment which at any time may become due to the contractor under this or any other contract with the purchaser. If this sum is not sufficient to cover the full amount recoverable, the contractor shall pay to the Purchaser on demand the remaining balance due. Similarly, if the purchaser has or makes any claim, whether liquidated or not, against the contractor under any other contract with the purchaser the amount payable to the contractor under the contract including the security deposit shall be withheld till such claims of the purchaser are finally adjudicated upon and paid by the contractor

16. LIEN IN RESPECT OF CLAIMS IN OTHER CONTRACTS

It is agreed that any sum of money due and payable to the contractor under any contract may be withheld or retained by way of lien by the purchaser or any other person or persons contracting through the purchaser against any claim of the purchaser or such other person or persons in respect of payment of a sum of money arising out of or under any other contract made by the contractor with the purchaser or with other such person or persons.

It is further agreed term of the contract that the sum of money so withheld or retained under this Clause by the purchaser will be kept withheld or

retained as such by the purchaser until the claim arising out of in the same contract or any other contract is either mutually settled or determined by the arbitrator, and that the contractor shall have no claim for interest or damages whatsoever on this account or on any other ground in respect of any sum of money withheld or retained under this Clause and duly notified as such to the contractor.

17. WARRANTY

The contractor warrants that stores to be supplied under the contract shall be free from all defects and faults in materials, workmanship and manufacture and shall be of the highest grade and consistent with the established and generally accepted standards for stores of the types under the contract in full conformity with the specifications, drawings or samples, if any and shall if operable, operate properly. This warranty shall expire (except in respect of complaints notified to the contractor prior to such date) twelve months after the date of receipt and acceptance of the last lot of stores under the contract at the ultimate destination stipulated in the contract.

In case any defect or deficiency in the stores supplied by the contractor under the contract appear to be discovered within twelve months from the date of receipt and acceptance of the stores in India, the contractor upon notification of such defects or deficiency by purchaser, shall forthwith take measure to rectify every such defect, deficiency or failure without any cost to the purchaser.

In case the contractor opts for return of stores for rectification/repair at their works, contractor shall furnish bank guarantee for the cost of stores as per Annexure-V or VI (as applicable) valid till acceptance of rectified/repared Stores. Further the warranty period will get extended for the period the Stores were not available to the purchaser for his use. If the contractor, after such notification, makes default or delay in rectifying all such defects, deficiencies or failure to the satisfaction of the purchaser, the purchaser may take recourse to the remedies provided for in Section C Part-A Clause no. 11 and 14.

18. PERMIT AND LICENSES

The contractor shall secure and pay for all licenses and permit at his end which he may be required to comply with all laws, ordinances and regulations etc. of the public authorities in connection with the performance of his obligations under the contract. The contractor shall be responsible for all damages and shall indemnify and save the purchaser from against all claims for damages and liability which may arise out of the failure of the contractor to secure and pay for any such licenses and permits and/or to comply fully with any and all applicable laws ordinances and regulations etc.

19. PATENT INDEMNIFICATION

The contractor shall indemnify and keep the purchaser indemnified from and against any and all claims, actions, costs, charges and expenses arising from or for infringement of patent rights, copyright or other protected rights, etc. of any design plans, diagrams, drawings in respect of the stores supplied by the contractor or any of the manufacturing methods or process adopted by contractor for the Stores supplied under the contract.

In the event of any claim being made or action being taken against the purchaser in respect of the matter referred to in Clause No. 19.1 above, the contractor shall promptly be notified thereof and he shall at his own expense, conduct all negotiations for the settlement of the same and any litigation that may arise there from.

In the event of any designs, drawing, plans or diagrams or any manufacturing methods or process furnished by the contractor etc. constituting infringement of patent or any other protected rights etc. and use thereof is restrained, the contractor shall procure for purchaser, at no cost to the latter, the rights to continue using the same or to the extent it is possible to replace the same so as to avoid such infringement and subject to approval by the purchaser or modify them so that they become non-infringing, but such modifications shall otherwise be to the entire satisfaction of the purchaser.

The provision of the Clause remains effective and binding upon the contractor even after the completion, expiration or termination of the contract.

20. MODE AND DOCUMENTATION OF PAYMENT

20.1. Payment for contracts in currency other than INDIAN RUPEES

Unless otherwise specified elsewhere, payment in full (excluding the amount of the commission included in the price payable directly by the purchaser to the Indian agent) shall be made by wire transfer within thirty days of final acceptance of stores.

The following documents are required to be sent to the purchaser immediately after shipment of consignment:

- 20.1.1. Bill of Lading/Negotiable Airway Bill evidencing shipment
- 20.1.2. Invoice for the shipment : Four copies
- 20.1.3. Packing list : Four copies
- 20.1.4. Shipping release from inspector or quality surveillance agency nominated by the purchaser for the purpose of inspection: Four copies, if applicable.
- 20.1.5. Shipping authorization from purchaser wherever required.

The contractor shall send invoice only for the net amount payable to him after deducting the amount of agency commission included in the invoice which would be paid to the Indian agents directly by the purchaser. However the contractor's invoice should separately reflect the amount of commission payable to his Indian agent.

20.2. PAYMENT FOR CONTRACTS IN INDIAN RUPEE

Unless otherwise mentioned elsewhere, payments for the contract will be made after final acceptance of stores and within a reasonable time on submission of following documents.

- i) GST compliant invoice in favour of paying authority duly pre-receipted.
- ii) Receiving voucher from Stores (RV).

Normally thirty days will be allowed for inspection and payment after receipt of the stores.

21. STATUTORY DEDUCTIONS

The purchaser has the right to make statutory deductions from the payments made to the contractor as applicable on the date of making

such payment as per the provisions of relevant Act or Rules made there under. Appropriate certificate to that effect will be provided by the purchaser's paying authority.

22. AGENCY COMMISSION

The amount of commission included in the price and payable to the Indian agents of the contractor shall be paid in INR directly to the Indian agents by the purchaser on the basis of an Invoice from the Indian agent. "Payment will be released to the Indian agents after receipt and final acceptance of the goods by the purchaser".

INSURANCE FOR CONTRACTS IN CURRENCY OTHER THAN INDIAN RUPEE

Transit insurance from warehouse to warehouse will be arranged by the purchaser through his underwriters unless this responsibility is specifically entrusted to the contractor in any particular case.

23. MARKING

The marking shall generally be as under:

Name and address of the consignee	Head - Stores Section, INSTITUTE FOR PLASMA RESEARCH (An Aided Institute of Dept. of Atomic Energy, Govt. of India) NEAR INDIRA BRIDGE, BHAT GANDHINAGAR-382428
Contract Number and Date	No. _____ Date _____
Brief Description of Goods	
Weight	
Dimension	
Ultimate Destination	
Port of Discharge	
Package Number	

Each package shall contain a packing note specifying the name and address of the contractor, the number and date of the contract, name and address of the consignee, description of the stores and the quantity contained in such package.

The inspector, wherever deputed by the purchaser under Section C Part-A Clause No. 6 may reject the stores if the same is not packed and/or marked as aforesaid and in case where the packing materials are specifically prescribed, if such materials are not in accordance with the terms of the contract.

24. CODE OF INTEGRITY

No official of a procuring entity or bidder or contractor shall act in contravention of the codes which include

- (i) Prohibition of
 - (a) making offer, solicitation or acceptance of bribe, reward or gift or any material benefit, either directly or indirectly, in exchange for an unfair advantage in the procurement process or to otherwise influence the procurement process.
 - (b) any omission, or misrepresentation that may mislead or attempt

to mislead so that financial or other benefit may be obtained or an obligation avoided.

- (c) any collusion, bid rigging or anticompetitive behavior that may impair the transparency, fairness and the progress of the procurement process.
- (d) improper use of information provided by the procuring entity to the bidder with an intent to gain unfair advantage in the procurement process or for personal gain.
- (e) any financial or business transactions between the bidder and any official of the procuring entity related to tender or execution process of contract; which can affect the decision of the procuring entity directly or indirectly any coercion or any threat to impair or harm, directly or indirectly, any party or its property to influence the procurement process.
- (f) obstruction of any investigation or auditing of a procurement process.
- (g) making false declaration or providing false information for participation in a tender process or to secure a contract;
- (ii) Disclosure of conflict of interest.
- (iii) Disclosure by the bidder of any previous transgressions made in respect of the provisions of sub-clause (i) with any entity in any country during the last three years or of being debarred by any other procuring entity.

- (iv) Institute for Plasma Research, after giving a reasonable opportunity of being heard, comes to the conclusion that a bidder or prospective bidder, as the case may be, has contravened the code of integrity, may take appropriate measures as deemed fit, including rejecting his bid and forfeiting EMD and/or debarring him from participating in future bidding.

25. LAW GOVERNING THE CONTRACT

This contract shall be governed by the laws of India for the time being in force. The marking of all stores must comply with the requirements of India Acts relating to Merchandise Marks and all the rules made under such Acts.

26. JURISDICTION

The Courts within the local limits (i.e. Gandhinagar) of whose jurisdiction the place from which the purchase order is issued is situation only shall, subject to Arbitration Clause, have jurisdiction to deal with and decide any matter out of this Purchase Order/Contract.

27. SETTLEMENT OF DISPUTES

The Purchaser and the Contractor shall make every effort to resolve amicably by direct informal negotiation any disagreement or dispute arising between them under or in connection with the Contract.

If the parties have failed to resolve their dispute or difference by such mutual consultation, then either the Purchaser or the Supplier may give notice to the other party of its intention to commence arbitration, as hereinafter provided, as to the matter in dispute, and no arbitration in respect of this matter may be commenced unless such notice is given. Any dispute or difference in respect of which a notice of intention to commence arbitration has been given in accordance with this Clause shall be finally settled by arbitration. Arbitration may be commenced prior to or after delivery of the Goods under the Contract.

28. Arbitration

In the event of any dispute or difference arising out or of in connection with any of the terms and conditions of the Purchase Order/Contract, the matter shall be referred to the Director, IPR for settlement. In case the parties to the Purchase Order are not in a position to settle the dispute mutually, the matter shall be referred to a Sole Arbitrator to be appointed in accordance with the Arbitration & Reconciliation Act, 1996 & Arbitration and Conciliation (Amendment) Act, 2015 as amended time to time.

29. TRANSFER OF OWNERSHIP

29.1 Ownership of the stores supplied by the foreign contractor shall be transferred to the purchaser in accordance with the payment terms or INCOTERMS accepted.

29.2 Ownership of the stores supplied by the Indian contractor shall be transferred to the purchaser when the stores are delivered and accepted by the purchaser

29.3 Transfer of title shall not in any way absolve the contractor from his responsibilities and liabilities under the contract. Notwithstanding the

transfer of ownership of the stores, the responsibility for care and custody thereof together with the risk of loss or damage thereto shall remain with the contractor until safe delivery of the stores to the purchaser' site.

INTELLECTUAL PROPERTY RIGHTS

All rights of design documents and drawings, if paid by the purchaser separately or compositely included in the contract cost, will remain with the purchaser and the contractor shall have no claim whatsoever on these rights.

30. EXERCISING THE RIGHTS AND POWERS OF THE PURCHASER

Director, Institute for Plasma Research is the authorized person to deal with, exercise, negotiate on behalf of the purchaser having all the rights, discretions and powers of the purchaser under this contract and any reference to the opinion of the purchaser in the terms and conditions contained in these General Conditions of Contract/Special Conditions of Contract shall mean and be construed as reference to the opinion of any of the persons authorized by him as mentioned in this Clause. All notices on behalf of the purchaser shall be issued by Director, Institute for Plasma Research.

31. TERMINATION OF CONTRACT

In case of non-compliance of any of the Terms and Conditions of the Contract, Purchaser reserves the right to terminate the contract after serving notice to the contractor.

Performance Security, if any, already available shall be forfeited.

In addition to the above, the contractor will be liable to be debarred and/or banned from participation against any tender issued by Institute for Plasma Research, including its regional units, and/or the bid of defaulting contractor is being considered for award of contract of stores.

PART-B

In addition to the General Conditions of Contract contained in Section C Part-A the following Special Conditions of Contract shall apply to contracts for design/manufacture, supply, installation and commissioning of plant/ machinery/equipment/instrument as the case may be . These Special Conditions of Contract in Part-B shall override the General Conditions of Contract, wherever there is any ambiguity/conflict.

SPECIAL CONDITIONS OF CONTRACT

1. RESPONSIBILITY FOR COMPLETENESS

All fittings or accessories which may not be specifically mentioned in the tender specifications of the contract but which are necessary are to be provided by the contractor without any extra charge and the stores comprising plant/machinery/equipment/instruments must be completed in all respect within the delivery date.

2. FINAL TEST

The final tests to ascertain the performance and guarantee shall commence within one month of completion of installation. The contractor will inform the purchaser well in advance the services/facilities required to start the final test, as mentioned in the contract.

3. REJECTION OF DEFECTIVE PLANT

If the completed plant or any portion thereof before it is finally accepted is found to be defective or fails to fulfill the requirements of the contract during the currency of the contract including warranty period, the purchaser shall give the contractor notice setting forth with the details of such defects or failure and the contractor shall forthwith rectify the defective plant or alter the same to make it comply with the requirement of the contract at the earliest and in any case not later than thirty days from the date of such intimation of the incident. In case the contractor fail to do so within the abovementioned time the purchaser may reject and replace at the cost of the contractor, the whole or any portion of the plant as the case may be, which is defective or fails to fulfill the requirement of the contract. Such replacement shall be carried out by the purchaser within a reasonable time and at reasonable price and to the same specifications as far as possible and under competitive conditions. The contractor shall be liable to pay to the purchaser the extra cost, if any, of such replacement procured and/or erected as provided for in the contract, such extra cost being the difference between the price paid by the purchaser under the contract for such replacement and the original price admitted in the contract placed with the contractor or the cost as determined by the purchaser out of the price admitted in the original contract, where separate price for such defective/rejected stores is not available in the contract. Contractor shall refund to purchaser any sum paid by the purchaser to the contractor in respect of such defective plant when rejected and no replacement is procured by the purchaser.

4. WARRANTY

The contractor shall provide warranty of stores supplied for a minimum period of twelve calendar months after the stores comprising plant/machinery/equipment/ instruments has been put into operation

(or a suitable mutually agreed longer period to be reckoned from the date of last major shipment depending upon the nature of the stores comprising plant/machinery/equipment/instrument) the contractor shall be responsible for any defects that may develop under conditions provided for in the contract and under proper use, arising from the faulty materials, design or workmanship in the plant or from faulty erection of the plant by the contractor, but otherwise and shall rectify such defects at his own cost when called upon to do so by the purchaser who shall state in writing such defects.

If it becomes necessary for the contractor to replace or renew any defective portions of the plant for purpose of rectification under this Clause, the provisions of this Clause shall apply to the portions of the plant so replaced or renewed until expiration of six months from the date of such replacement or renewal or until the end of the above mentioned period of twelve months whichever is later. If any defect is not rectified within a reasonable time, the purchaser may cancel the contract or part thereof whose decision will be final and binding on the contractor and the contractor will refund the money so paid to the contractor forthwith without any demur.

All inspections adjustments, replacements or renewals carried out by the contractor during the warranty period shall be subject to the same conditions as in the contract.

The contractor shall, give advance notice of not less than twelve months to the purchaser whenever spare parts of the stores are going out of production so that the purchaser may order requirement of spares in one lot or more lots if so desired.

The contractor shall further guarantee up to the plant/equipment/instrument/stores life that if spare parts go out of production, the contractor will make available blue prints, drawings of spare parts and specifications of stores at no cost to the purchaser, if and when required in connection with the stores to enable purchaser to fabricate or procure spare parts from other sources.

The provision of this Clause shall remain effective and binding upon the contractor even after the completion and fifteen years of expiration of the contract or till the stores supplied under the contract is in use by the purchaser, whichever is earlier.

5. ERECTION AND COMMISSIONING

In all cases where contract provide for supervision of erection and commissioning or for test at the purchaser's premises, the contractor shall indicate in advance the services required for installation and commissioning and the purchaser except where otherwise specified, shall provide free of charge, such labour, materials, fuels, apparatus and instruments as may be required from time to time and as may reasonably be demanded by the contractor to carry out efficiently such supervision of erection and commissioning and for the requisite test. In case of contract requiring electricity or services for the completion of erection, commissioning and testing at site, such electricity or services shall be supplied free of cost to the contractor or as specified in the NIT.

Action by the purchaser under the Clause shall not relieve the contractor of his warranty obligations under the contract.

6. TRAINING

The contractor shall, if required by the purchaser, provide facilities for the practical training of purchaser's engineering or technical personnel and for their active association on the manufacturing process through the manufacturing period of the contract/stores, number of such personnel shall be mutually agreed upon.

7. PAYMENT TERMS

7.1.FOR CONTRACTS IN INDIAN RUPEE ONLY

90% of total contract value exclusive of charges for installation and commissioning, if applicable after delivery of all consignment and preliminary inspection by purchaser's inspector on submission of the following:

- 7.1.1.1. GST compliant invoice in favour of paying authority duly pre-receipted.
- 7.1.1.2. Original shipping release containing the stamp and signature of the purchaser's inspection authority.
- 7.1.1.3. Preliminary Inspection Report alongwith Material receipt confirmation documents from Stores.

And balance payment will be released against following documents:

- i) Installation, commissioning and training certificate if applicable
- ii) Receiving voucher receipt from Stores.

7.2.FOR CONTRACTS IN CURRENCIES OTHER THAN INDIAN RUPEE

Unless otherwise specified elsewhere in the NIT, payment for the stores will be made as follows

90% of total contract value exclusive of charges for installation and commissioning, if applicable by Irrevocable Letter of Credit on submission of the following documents:

- i. Bill of Lading/Negotiable Airway Bill evidencing shipment
- ii. Invoice for the shipment : Four copies
- iii. Packing List : Four copies
- iv. Shipping authorization from purchaser wherever required. if applicable,
- v. Any other document(s) as specified in the contract.

An advance copy of invoice along with details of documents forwarded through bank should be sent to the Paying Authority mentioned in the contract to enable him to verify the documents and honor the claim without delay.

The contractor shall be responsible to make available to the purchaser the documents which are essential for arranging customs clearance in India. The contractor shall arrange through his bank to have the documents air mailed to the purchase's bank without any delay. He shall also arrange to forward directly to the purchaser, three copies of Airway Bill, along with a copy of the invoice and packing list. If the purchaser incurs any extra expenditure by way of penalty payable to the Airport authorities in India or any other such expenditure due to delay in receipt of shipping documents specified by purchaser, the contractor shall be responsible for making good such extra expenditure incurred by the purchaser.

While the purchaser shall bear the bank charges payable to his bankers in India (State Bank of India) the contractor shall bear all the bank

charges payable outside India including the charges towards advising/amendments, commission.

The contractor shall send invoice only for the net amount payable to him after deducting the amount of agency commission included in the invoice which would be paid to the Indian agents directly by the purchaser in Indian Rupee. However the contractor's invoice should separately reflect the amount of commission payable to his Indian agent.

Balance payment will be made by wire transfer after final inspection, testing, installation, commissioning (where applicable), final acceptance and submission of PSDBG acceptance letter from the Purchaser against following documents.

- i. Acceptance Report
- ii. Receiving voucher from Stores

8. FORCE MAJEURE

DEFINITION OF FORCE MAJEURE

Force Majeure shall mean any event which is beyond the control of the contractor or the purchaser, as the case may be, which they could not foresee or with a reasonable amount of diligence could not have foreseen and which substantially affects the performance of the contract, such as

war, hostilities or warlike operations (whether a state of war be declared or not), invasion, act of foreign enemy and civil war.

rebellion, insurrection, mutiny, usurpation of civil or military government, civil commotion.

embargo, import restriction, confiscation, nationalization, mobilization, commandeering or requisition by or under the order of Central, State Government or Local Authority in India or any other act or failure to act, of any local, state or national government in India

riot

state/region/country wide transporters strike

earthquake, landslide, volcanic activity, fire, flood or inundation, tidal wave, typhoon or cyclone hurricane, storm, lightning and pressure waves or other natural disaster

nuclear event causing nuclear radiation, radioactive

contamination

NOTICE OF FORCE MAJEURE

If either party is prevented, hindered or delayed from or in performing any of its obligations under the contract by an event of force majeure, then it shall notify the other in writing of the occurrence of such event and the circumstances thereof within fourteen days after the occurrence of such event. A party shall give notice to the other party when it ceases to be affected by the force majeure. Failure to notify the purchaser about occurrence of such event within the time frame specified, the contractor shall have no right to claim any provisions under clause 8.4 below (consequences of force majeure)

DUTY TO MINIMISE THE EFFECT

The party or parties affected by the event of force majeure shall use reasonable efforts to mitigate the effect thereof upon its or their

performance of the contract and to fulfill its or their obligations under the contract

CONSEQUENCES OF FORCE MAJEURE

The party who has given notice of force majeure shall be excused from the performance or punctual performance of its obligations under the contract for so long as the relevant event of force majeure continues and to the extent that such party's performance is prevented, hindered or delayed. The delivery time shall be re- fixed in accordance with Section C Part-A Clause 10, even though such force majeure event may occur after contractor's performance of his obligations has been delayed for other cause. No delay or non-performance by either party hereto caused by the occurrence of any event of force majeure shall

Constitute a default or breach of the contract give rise to any claim for damages or additional cost or expense occasioned thereby; if and to the extent that such delay or non-performance is caused by the occurrence of an event of force majeure. If the performance of the contract is substantially prevented, hindered or delayed for a single period of more than sixty days or an aggregate period of more than one hundred and twenty days on account of one or more events of force majeure during the currency of the contract, the parties will attempt to develop a mutually satisfactory solution.

FORCE MAJEURE AFFECTING SUB-CONTRACTOR

Conditions as enumerated in Section C Part B Clause 8 will be applicable to sub- contractor.

If any sub-contractor is entitled under the contract for Force Majeure on terms additional to or broader than those specified in this Clause, such additional or broader Force Majeure events or circumstances shall not excuse the Contractor's non-performance or entitle him to relief under this Clause.

9. LIMITATIONS

Anything in this Contract to the contrary notwithstanding

The affected party shall not be relieved from obligations under this contract to the extent any gross negligence of the affected party aggravates the force majeure event; and

Force majeure shall not apply to obligations of either party to make payments to the other party under the contract.

10. HINDRANCES

The contractor is required to maintain hindrance register for reporting hindrance if any, while executing the work, as per Annexure-X

. The contractor shall get record of hindrances in the hindrance register(s) approved/ endorsed by the purchaser. Such hindrance in the work endorsed by the purchaser will only be taken into consideration for granting delivery date re-fixation.

ANNEXURE

BANK GUARANTEE/ HINDRANCE
REGISTER FORMAT

ANNEXURE-I: PERFORMANCE SECURITY BOND

[Note: Bank Guarantee shall be got executed from a Nationalised / Scheduled commercial Bank (Except Co-operative Bank and Grameen Banks) only on non-judicial stamp paper of appropriate value]

Institute for Plasma Research
(Acting through) Director/ Head- Purchase and Stores Department/ Head-Purchase Section
Institute for Plasma Research

1. WHEREAS on or about the (Date of the Purchase Order) M/s. _____ a Company incorporated under the Companies Act 1956 and having its registered office at _____ (hereinafter referred to as 'The Contractor') entered into an agreement bearing No. _____ (hereinafter referred to as 'The Contract'), with Institute for Plasma Research acting through Director/ Head- Purchase and Stores Department/ Head-Purchase Section, Institute for Plasma Research, Bhat, Near Indira Bridge, Gandhinagar-382428. (hereinafter referred to as (Purchaser) for supply of _____ (hereinafter referred to as 'The Equipment').
2. AND WHEREAS under the terms & conditions of the contract, the Contractor shall furnish Performance Security Bond for an amount of Rs. _____ (Rupees _____ only) representing 3% of the total value of the contract in the form of a bank guarantee, in a manner herein contained duly executed by a scheduled/nationalised bank towards satisfactory performance of the contract and performance of the equipment and against any loss or damage caused to or suffered or would be caused to or suffered by the Purchaser by reason of any breach by the said Contractor(s) of any terms and conditions contained in the said agreement. The Performance Security Bond shall be valid till satisfactory completion of Defect Liability Period covering the Warranty/Guarantee period of the equipment as per the terms & conditions of the said agreement.
3. NOW WE, the _____ (Bank) in consideration of the promises do hereby agree and undertake to pay to the Institute for Plasma Research, (the purchaser) on behalf of the Contractor, the said sum of Rs. _____ (Rupees _____ Only), the amount due and payable under the guarantee without any demur, merely on a demand from the Institute for Plasma Research stating that the amount claimed is due by way of loss or damage caused to, or suffered by, the Purchaser by reason of any breach by the said Contractor of any of the terms and conditions contained in the said agreement or by reason of the contractors failure to perform the said agreement or by reason of unsatisfactory performance of the equipment during the Warranty period. Any such demand, made on the bank, shall be conclusive as regards the amount due and payable by the Bank under this guarantee. However, our liability under this guarantee shall be restricted to an amount not exceeding Rs. _____ (Rupees _____ only).
4. WE undertake to pay to the Purchaser the said sum of ₹ _____ (Rupees _____ Only), demanded notwithstanding any dispute or disputes raised by the Contractor(s), in any suit on proceedings pending before any Court or Tribunal relating thereto, our liability under this presents being absolute irrevocable and unequivocal. The payment so made by us under this bond shall be a valid discharge of our liability for payment thereunder and the Contractor shall have to no claim against us for making such payment.
5. WE HEREBY further agree that the decision of the Institute for Plasma Research as to the

amount of damages suffered by the Purchaser by reasons(s) of any breach by the said Contractor or whether the said equipment is giving satisfactory performance or not during the Warranty Period as per the terms and conditions of the said agreement, shall be final and binding on us.

6. AND WE, the _____(Bank) do hereby further agree that our liability hereinunder shall not be discharged by virtue of any agreement between the Purchaser and the Contractor whether with or without our knowledge and/or consent and shall remain in full force and effect during the period that would be taken for the performance of the said agreement or by reason of the Purchaser showing any indulgence or forbearance to the Contractor whether as to payment, time for performance, or any other matter whatsoever relating to the contract, which but for this provision, would amount to discharge of the surety under the law.
7. THIS guarantee will not be discharged due to the change in the constitution of the Bank or the Contractor.
8. OUR Guarantee shall remain in force until _____and unless a claim under the guarantee is lodged with us within three months from the said date, all rights of the Purchaser under the guarantee shall be forfeited and we shall be relieved and discharged from all our liabilities hereunder.
9. Notwithstanding anything contrary contained in any law for the time being in force or banking practice, this guarantee shall not be assignable or transferable by the beneficiary. Notice or invocation by any person such as assignee, transferee or agent of beneficiary shall not be entertained by the bank. Any invocation of the guarantee can be made only by the beneficiary directly.

Dated the _____ day of _____ 202_

For _____

(Indicate the Name of bank)

ANNEXURE-V: BANK GUARANTEE FORMAT FOR RE-EXPORT/RETURN OF
REJECTED FOR EQUIPMENT REPAIRS / REPLACEMENT.

(By Indian/Foreign Contractor)

Head-Purchase and Stores Department, Institute for Plasma Research
On behalf of The Director, Institute for Plasma Research
Bhat, Near Indira Bridge,
Gandhinagar, Gujarat, India
Pin- 382428

Whereas on or about the _____ day of _____ 20 , M/s. _____ a company having incorporated their office at _____ (hereinafter referred to as 'the Contractor') entered into an Contract No. _____ dt. _____ (hereinafter referred to as 'the Contract') with the Head-Purchase and Stores Department, Institute for Plasma Research, on behalf of the Director, Institute for Plasma Research (Hereinafter referred to as 'the Purchaser') for manufacture and supply of _____ Nos. of (hereinafter referred to as the instrument') at a cost of _____ (in words).

Whereas as per the terms and conditions of the Contract, the Contractor had delivered to the consignee all the _____ Nos. of instruments, out of which _____ No./s. of the instrument costing _____ (in figure and words) was found defective and not working satisfactorily after its receipt by the consignee and therefore the instrument received from the Contractor was rejected by the Purchaser.

Whereas as per the terms and conditions of the Contract, the Contractor has agreed to either repair or replace the instrument, as is deemed fit, free of cost, to the purchaser within a period of _____ months from the date of receipt of the rejected instrument by the Contractor, under the warranty conditions of the Contract.

Whereas, as per the Purchaser policy, the Contractor was required to furnish a Bank Guarantee for full value of the defective instrument/s amounting to _____ (in figure and words) as a safeguard to the Purchaser on account of any damage/loss that may be caused or suffered by the Purchaser due to the Contractor's inability/failure to return the instrument duly repaired or supply a new instrument in replacement of the defective instrument within the specified time and also when the instruments lie under the Contractor's custody, control or possession.

Whereas the Contractor, based on the Purchaser's requirement has agreed to furnish such a Bank Guarantee as a safeguard to the Purchaser interest as indicated in para 4 above, valid till the return of the repaired instruments or a replacement thereof, to the Purchaser.

Whereas, we, _____ (name and address of the Bank) (herein after referred to as 'the Bank'), in consideration the Purchaser having agreed to despatch the defective instrument to the Contractor's works on freight to pay basis and Contractor having agreed to repair and return the defective instrument duly repaired or arrange free replacement of the defective instrument on freight paid/CIF _____ basis, do hereby agree and undertake to indemnify the Purchaser and keep the Purchaser indemnified to the extent of a sum not exceeding _____ (in figure and words.) against any loss or damage that may be caused or suffered by the Purchaser by reason of the Contractor either no returning the repaired instrument or arrange free replacement within a specified time and also when the instrument lie under the custody, control or possession of the Contractor.

We, the Bank, do hereby undertake to pay to the Purchaser, the amount due and payable under this Guarantee, without any demur, merely on a demand from the Purchase Officer, Institute for Plasma Research on behalf of the Purchaser, stating that the amount claimed is due by way of loss or damage caused to or would be caused to or suffered by the Purchaser by reason of the Contractor either not returning the instrument duly repaired or arrange free replacement to the Purchaser and also when the instrument lie under the custody, control or possession of Contractor. Any such demand on the Bank shall be conclusive as regards the amount due and payable by the Bank under this Guarantee. However, our liability under this Guarantee shall be restricted to an amount not exceeding _____ (in figure and words).

We, the Bank, undertake to pay to the Purchaser any money so demanded notwithstanding any dispute or disputes raised by the Contractor/s or by agents in any suit or proceeding pending before any court or tribunal relating thereto our liability under this present being absolute and unequivocal.

The payment so made by us under this bond shall be a valid discharge of our liability for payment thereunder and the Contractor/s and the agents shall have no claim against us for making such payment.

And we, the Bank, hereby further agree that the decision of the said Head-Purchase and Stores Department, Institute for Plasma Research as to whether the Contractor has committed breach of any such terms and conditions of the Contract or not and as to the amount of damage or loss assessed by the said Head-Purchase and Stores Department, Institute for Plasma Research on account of such breach would be final and binding on us.

We, the Bank, further agree with the Purchaser that the Purchaser shall have the fullest liberty without our consent and without affecting in any manner our obligations hereunder to vary any of the terms and conditions of the said Contract or to extend time for performance by the said Contractor from time to time or to postpone for any time or from time to time, any of the powers exercisable by the Purchaser against the said Contractor/s and to forbear or enforce any of the terms and conditions relating to the said Contract and we shall not be relieved from our liability by reason of any such variation or extension being granted to the said Contractor/s or for any forbearance, act or commission on the part of the Purchaser or any indulgence by the Purchaser to the said Contractor/s or by any such matter or thing whatsoever which under the law relating to sureties would, but for this provision, have effect of so relieving us.

This Guarantee will not be discharged due to the change in the constitution of the Bank, the Contractor or the agent.

Our Guarantee shall remain in force until and unless a claim under the Guarantee is lodged with us within three months from that date, all rights of the Purchaser under the Guarantee shall be forfeited and we shall be relieved and discharged from all liabilities thereunder.

Dated the _____ day of _____ 202_

For _____

(Indicate the Name of bank)

ANNEXURE VI: BANK GUARANTEE FORMAT FOR RE-EXPORT OF REJECTED EQUIPMENT FOR REPAIRS / REPLACEMENT.

(By local agents of foreign Contractor)

Head-Purchase and Stores Department, Institute for Plasma Research
On behalf of The Director, Institute for Plasma Research
Bhat, Near Indira
Bridge, Gandhinagar,
Gujarat, India
Pin-382428

Whereas on or about the _____ day of _____ 20 , M/s. _____, a company having incorporated their office at _____ (hereinafter referred to as 'the Contractor') entered into a Contract bearing No. _____ dt. _____ (hereinafter referred to as 'the Contract') with the Head-Purchase and Stores Department, Institute for Plasma Research, on behalf of the Director, Institute for Plasma Research, Gandhinagar, Gujarat, (Hereinafter referred to as 'the Purchaser') for manufacture and supply of Nos. _____ of (hereinafter referred to as the instrument') at a cost of _____ (in figures and words). The Contract recognizes M/s. _____ (name and address) as the Indian agent of the Principals M/s. _____ in India.

Whereas as per the terms and conditions of the Contract, the Contractor had delivered to the consignee all the _____ instrument costing _____ (in figure and words) was found defective and not working satisfactorily after its receipt by the consignee and therefore the instrument received from the Contractor was rejected by the Purchaser.

Whereas as per the terms and conditions of the Contract, the Contractor has agreed to either repair or replace the instrument, as is deemed fit, free of cost, to the purchaser within a period of _____ months from the date of receipt of the rejected instrument by the Contractor, under the warranty conditions of the Contract.

Whereas, as per the Purchaser policy, the Contractor was required to furnish a Bank Guarantee for full value of the defective instruments amounting to (in figure and words) as a safeguard to the Purchaser on account of any damage/loss that may be caused or suffered by the Purchaser due to the Contractor's inability/failure to return the instrument duly repaired or supply a new instrument in replacement of the defective instrument within the specified time and also when the instruments lie under the Contractor's. custody, control or possession. As the Indian agent has agreed to furnish the Bank Guarantee on behalf of the Principal in this Contract, M/s. _____ is required to execute the Bank Guarantee.

Whereas the Contractor, based on the Purchaser's requirement has agreed to furnish such a Bank Guarantee as a safeguard to the Purchaser interest as indicated in para 4 above, valid till the return of the repaired instruments or a replacement thereof, to the Purchaser.

Whereas, we, (the name and address of the Bank) (herein after referred to as 'the Bank'), in consideration of the Purchaser having agreed to despatch the defective instrument to the Contractor's works on freight to pay basis and Contractor having agreed to repair and return the defective instrument duly repaired or arrange free replacement of the defective instrument on freight paid /CIF _____ basis, do hereby agree and undertake to indemnify the Purchaser and keep the Purchaser indemnified to the extent of a sum not exceeding _____ (in figure and words) against any loss or damage that may be caused or suffered by the Purchaser by reason of the Contractor either not returning the repaired instrument or arrange free replacement within a specified time and also when the instrument lie under the custody, control or possession of the Contractor.

We, the Bank, do hereby undertake to pay to the Purchaser, the amount due and payable under this Guarantee, without any demur, merely on a demand from the Purchase Officer, Institute for Plasma Research, stating that the amount claimed is due by way of loss or damage caused to

or would be caused to or suffered by the Purchaser by reason of the Contractor either not returning the instrument duly repaired or arrange free replacement to the Purchaser and also when the instrument lie under the custody, control or possession of Contractor. Any such demand on the Bank shall be conclusive as regards the amount due and payable by the Bank under this Guarantee. However, our liability under this Guarantee shall be restricted to an amount not exceeding_____ (in figure and words).

We, the Bank, undertake to pay to the Purchaser any money so demanded notwithstanding any dispute or disputes raised by the Contractor/s or by agents in any suit or proceeding pending before any court or tribunal relating thereto our liability under this present being absolute and unequivocal.

The payment so made by us under this bond shall be a valid discharge of our liability for payment thereunder and the Contractor/s and the Indian agents shall have no claim against us for making such payment.

And we, the Bank, hereby further agree that the decision of the said Head-Purchase and Stores Department as to whether the Contractor has committed breach of any such terms and conditions of the Contract or not and as to the amount of damage or loss assessed by the said Head-Purchase and Stores Department, Institute for Plasma Research on account of such breach would be final and binding on us.

We, the Bank, further agree with the Purchaser that the Purchaser shall have the fullest liberty without our consent and without affecting in any manner our obligations hereunder to vary any of the terms and conditions of the said Contract or to extend time for performance by the said Contractor from time to time or to postpone for any time or from time to time, any of the powers exercisable by the Purchaser against the said Contractor/s and to forbear or enforce any of the terms and conditions relating to the said Contract and we shall not be relieved from our liability by reason of any such variation or extension being granted to the said Contractor/s or for any forbearance, act or commission on the part of the Purchaser or any indulgence by the Purchaser to the said Contractor/s or by any such matter or thing whatsoever which under the law relating to sureties would, but for this provision, have effect of so relieving us.

This Guarantee will not be discharged due to the change in the constitution of the Bank, the Contractor/s or the agents.

Our Guarantee shall remain in force until _____ and unless a claim under the Guarantee is lodged with us within three months from that date, all rights of the Purchaser under the Guarantee shall be forfeited and we shall be relieved and discharged from all liabilities thereunder.

Dated the _____ day of _____ 202_

For _____

(Indicate the Name of bank)

ANNEXURE-VII: BANK GUARANTEE FORMAT FOR SUPPLY OF FREE ISSUE MATERIAL
(By Indian/Foreign Contractor)

Head-Purchase and Stores Department, Institute for Plasma Research
On behalf of The Director, Institute for Plasma Research
Bhat, Near Indira
Bridge, Gandhinagar,
Gujarat, India
Pin-382428

Whereas on or about the _____ (date), the Head-Purchase and Stores Department, Institute for Plasma Research, on behalf of the Director, Institute for Plasma Research, (hereinafter referred to as the Purchaser) has entered into a Contract bearing No. _____ Dated _____ for manufacture, inspection, testing and safe delivery of _____ (herein after referred to as the equipment) with M/s. _____ having their office at _____ (hereinafter referred to as the Contractor.)

And whereas in terms of the above said agreement, the Purchaser is required to supply free issue materials costing Rs. _____ as listed out in the agreement for the manufacture of the equipment at the Contractor's site, and that the Purchaser has agreed to authorise the Contractor to collect the free issue materials from the Purchaser's site subject to the Contractor furnishing a Bank Guarantee for Rs. _____ in a manner herein specified towards the safeguard of free issue materials.

Now, we _____ (bank) in consideration of the Purchaser having agreed to authorise issue of free issue material for collection by the Contractor, hereby undertake to indemnify the Purchaser and keep the Purchaser indemnified to the extent of the full value of the free issue material till such time the materials are lying under the custody/possession/control of the Contractor and till the equipment along with balance material, if any, are received by the Purchaser after manufacture of the equipment.

We, _____ (bank) do hereby undertake to pay to the Head-Purchase and Stores Department, Institute for Plasma Research, the amount due and payable under this Guarantee without any demur, merely on a demand from the Head-Purchase and Stores Department, Institute for Plasma Research, on behalf of the Purchaser stating that the amount claimed is due by way of loss, destruction, deterioration or damage caused to or suffered by the Purchaser to the purchaser's material thereby resulting in a loss to the Purchaser while they are lying under the Contractor's custody, possession or control or on account of the Contractor's failure to fulfill any of the contractual obligations.

Any such demand made on the Bank shall be conclusive as regards the amount due and payable by the Bank under this Guarantee. However, our liability under this Guarantee shall be restricted to an amount not exceeding Rs. _____

We, _____ (Bank) undertake to pay to the Purchaser any money so demanded

notwithstanding any disputes raised by the Contractors in any suit or proceeding
dispute or any pending before any court of Tribunal relating

thereto our liability under this present being absolute and unequivocal. They payment so made by us under this Bond shall be a valid discharge of our liability for payment thereunder and the Contractors shall have no claim against us for making such payments.

We, _____(Bank), also agree that the decision of the Purchase Officer, Institute for Plasma Research, Gandhinagar, Gujarat as to whether the Contractor has caused any loss/destruction or deterioration or damage to the Purchaser's material while these are lying under his custody/possession/control from whatever cause arising as also on the quantum of damage suffered by the Purchaser shall be final and binding on us.

We, _____(bank) further agree with the Purchaser that the Purchaser shall have the fullest liberty without our consent and without affecting in any manner our obligations hereunder to vary any of the terms and conditions of the said Agreement or to extend time for performance by the said Contractors from time to time or to postpone for any time or from time to time any of the powers exercisable by the Purchaser against the said Contractors and to forbear or enforce any of the terms and conditions relating to the said Agreement and we shall not be relieved from our liability by reason of any such variation or extension being granted to the said Contractors or for any forbearance, act or omission on the part of the said Purchaser or any indulgence by the Purchaser to the said Contractors or by any such matter or thing whatsoever which under the law relating to sureties would but for this provision, have the effect of so relieving us.

This Guarantee will not be discharged due to change in the constitution of the Bank or the Contractors.

Our Guarantee shall remain in full force until _____and unless a claim under the guarantee is lodged with us within six months from that date all rights of the Purchaser under the guarantee shall be relieved and discharged from all liabilities thereunder.

Dated the _____ day of _____ 202_

For _____

(Indicate the Name of bank)

ANNEXURE-VIII: BANK GUARANTEE FORMAT FOR FIM
(Foreign Currency Contract)
(to be executed by the Indian Agent)

Head-Purchase and Stores Department, Institute for Plasma Research
On behalf of The Director, Institute for Plasma Research
Bhat, Near Indira
Bridge, Gandhinagar,
Gujarat, India
Pin-382428

Whereas on or about the _____ day of _____ 200 , M/s. _____, a company having incorporated their office at _____ (hereinafter referred to as 'the Contractor') entered into a Contract bearing No. _____ dt. _____ (hereinafter referred to as 'the Contract') with the Head-Purchase and Stores Department, Institute for Plasma Research, on behalf of the Director, Institute for Plasma Research (Hereinafter referred to as 'the Purchaser') for manufacture and supply of Nos. _____ of (hereinafter referred to as the instrument') at a cost of _____ (in figures and words). The Contract recognises M/s. _____ (name and address) as the Indian agent of the Principals M/s. _____ in India.

And whereas in terms of the above said agreement, the Purchaser is required to supply free issue materials costing Rs. _____ as listed out in the agreement for the manufacture of the equipment at the Contractor's site, and that the Purchaser has agreed to authorise the Contractor to collect the free issue materials from the Purchaser's site subject to the Contractor furnishing a Bank Guarantee for Rs. _____ in a manner herein specified towards the safeguard of free issue materials. As the Indian agent has agreed to furnish the Bank Guarantee on behalf of the Principal in this Contract, M/s. _____ is required to execute the Bank Guarantee.

Now, we _____ (bank) in consideration of the Purchaser having agreed to authorise issue of free issue material for collection by the Contractor, hereby undertake to indemnify the Purchaser and keep the Purchaser indemnified to the extent of the full value of the free issue material till such time the materials are lying under the custody/possession/control of the Contractor and till the equipment along with balance material, if any, are received by the Purchaser after manufacture of the equipment.

We, _____ (bank) do hereby undertake to pay to the Head-Purchase and Stores Department, Institute for Plasma Research, the amount due and payable under this Guarantee without any demur, merely on a demand from the Head-Purchase and Stores Department, Institute for Plasma Research, on behalf of the Purchaser stating that the amount claimed is due by way of loss, destruction, deterioration or damage caused to or suffered by the Purchaser to the purchaser's material thereby resulting in a loss to the Purchaser while they are lying under the Contractor's custody, possession or control or on account of the Contractor's failure to fulfill any of the contractual obligations.

Any such demand made on the Bank shall be conclusive as regards the amount due and payable by the Bank under this Guarantee. However, our liability under this Guarantee shall be restricted to an amount not exceeding Rs. _____

We, _____(Bank) undertake to pay to the Purchaser any money so demanded notwithstanding any dispute or any disputes raised by the Contractors in any suit or proceeding pending before any court of Tribunal relating thereto our liability under this present being absolute and unequivocal. The payment so made by us under this Bond shall be a valid discharge of our liability for payment thereunder and the Contractors shall have no claim against us for making such payments.

We, _____(Bank), also agree that the decision of the Head-Purchase and Stores Department, Institute for Plasma Research, Gandhinagar, Gujarat as to whether the Contractor has caused any loss/destruction or deterioration or damage to the Purchaser's material while these are lying under his custody/possession/control from whatever cause arising as also on the quantum of damage suffered by the Purchaser shall be final and binding on us.

We, _____(bank) further agree with the Purchaser that the Purchaser shall have the fullest liberty without our consent and without affecting in any manner our obligations hereunder to vary any of the terms and conditions of the said Agreement or to extend time for performance by the said Contractors from time to time or to postpone for any time or from time to time any of the powers exercisable by the Purchaser against the said Contractors and to forbear or enforce any of the terms and conditions relating to the said Agreement and we shall not be relieved from our liability by reason of any such variation or extension being granted to the said Contractors or for any forbearance, act or omission on the part of the said Purchaser or any indulgence by the Purchaser to the said Contractors or by any such matter or thing whatsoever which under the law relating to sureties would but for this provision, have the effect of so relieving us.

This Guarantee will not be discharged due to change in the constitution of the Bank or the Contractors.

Our Guarantee shall remain in full force until _____ and unless a claim under the guarantee is lodged with us within six months from that date all rights of the Purchaser under the guarantee shall be relieved and discharged from all liabilities thereunder.

Dated the _____ day of _____ 202_

For _____

(Indicate the Name of bank)

ANNEXURE-X: FORMAT FOR HINDRANCE REGISTER

Sl. No.	From	To	Nature of Hindrances in execution of Contract	Remarks with signature of Contractor	Remarks with Signature of Purchaser's representative

(To be printed in letter head)

Annexure-XI

**Self-Certification under preference to Make in India order
Certificate**

In line with Government Public Procurement Order No. P-45021/2/2017-PP (BE-II) dated 04.06.2020 and its amendments, we hereby certify that we M/s. _____ are local supplier meeting the requirement of minimum local content i.e., _____% excluding transportation, insurance, installation, commissioning, testing, training and after sales service support like AMC/CMC etc. as defined in above orders for the material against IPR Enquiry/Tender No **IPR/TN/PUR/TPT/ET/21-22/012** dated **31-08-2021**. Details of location at which local value addition will be made as follows: _____.

We also understand, false declarations will be in breach of the code of integrity under rule 175(1) (i) (h) of the General Financial Rules for which a bidder or its successors can be debarred for up to two years as per Rule 151(iii) of the General Financial Rules along with such other actions as may be permissible under law.

Thanking You,

Signature with date:

Name:

Designation:

Official Seal

(To be printed in letter head)

ANNEXURE-XII

Annexure to Bid Form: Eligibility Declarations

(To be submitted as part of tender/Technical Bid)
(on company letter head)
(Along with supporting documents, if any)

Tender No. IPR/

Tender Title:

Bidder's Name: _____

(Address and contact details)

Date: _____

Bidder's Reference No. _____

Restrictions on procurement from Bidders from a country or countries, or a class of countries under Rule 144(xi) of the General Financial Rules 2017.

“We have read the clause regarding restrictions on procurement from a Bidder of a country which shares a land border with India; and solemnly certify that we are not from such a country or, if from such a country, we are registered with the Competent Authority (copy enclosed). We hereby certify that we fulfill all requirements in this regard and are eligible to be considered.”

Penalties for false or misleading declarations:

We hereby confirm that the particulars given above are factually correct and nothing is concealed and also undertake to advise any future changes to the above details. We understand that any wrong or misleading self-declaration by us would be violation of Code of integrity and would attract penalties as mentioned in this tender document, including debarment.

(Signature with date)

(Name and designation)

Duly authorized to sign Bid for and on behalf of

(Name & address of the Bidder and Seal of Company)

SECTION 'D' :
TECHNICAL SPECIFICATIONS OF STORES
AND
DRAWINGS

Please see attachment to the tender

SECTION 'E' :

PRICE SCHEDULE

Please see attachment to the tender



प्लाज्मा अनुसंधान संस्थान
(भारत सरकार के परमाणु ऊर्जा विभाग का सहायता प्राप्त संस्थान)
इंदीरा ब्रिज के पास, भाट, गांधीनगर – 382428, भारत
दूरभाष: 079-23962020/23962021, फ़ैक्स: 079-23962277

ADDITIONAL CONDITIONS OF CONTRACT against

IPR Tender No: IPR/TN/PUR/TPT/ET/21-22/043 Dated: 14/02/2022

Following clauses are deleted in Form No. m IPR-P-103

(Section-A)

- a) 47.2

Following clause is modified in Form No.e IPR-PUR-103

7 VALIDITY OF BIDS

- 7.1 Bids shall be kept valid for acceptance for a period till **120 Days** from the date of **Opening of PART-I (Technical Bid)**. Bids with shorter validity period shall be rejected without any notice to the bidder.

Following clauses are deleted in Form No. IPR-P-100

PART-A

- a) 7.2
b) 20.1
c) 22
d) 29.1

PART-B

- a) 7.2

Following clauses is modified in Form No. IPR-P-100

PART-A

- 29.2 Ownership of the stores supplied by the contractor shall be transferred to the purchaser when the stores are delivered and accepted by the purchaser.

Following clause is modified in Form No. IPR-P-100

PART-B

- 7.1** The Clause Sr. No. 7.1 under heading Payment Terms of Section-B “General Conditions of Contract” of Form No. e_IPR-PUR-103 (Terms and Conditions) is replaced with the following:

Payment: Unless otherwise agreed to in writing between the Purchaser and the Contractor, payment for the delivery of the tendered items, will be made as follows.

- a) 80% of basic price of Item Sr. No. 1.01 of Price-Schedule + 100% of all other charges will be paid after receipt of all material at IPR, Gandhinagar Site, its physical verification by representative of IPR and on receipt of Invoice in triplicate.
- b) Balance 20% of basic price of Item Sr. No. 1.01 of Price-Schedule and 100% of Item Sr. No. 1.02 of Price-Bid will be paid within 30 days after satisfactory completion of site acceptance tests (SAT) and on receipt of final invoice.

Following Annexures are deleted in Form No. IPR-P-100

Following Annexures are added in Form No. IPR-P-100

Annexure-XIII (**COMMERCIAL TERMS & CONDITIONS**)

Vendor/ Bidder should upload the duly filled (signed and stamped) copy of commercial bid (unpriced) as per Annexure-XIII

IMPORTANT NOTE:

- 1) QUOTATIONS ARE INVITED IN INDIAN CURRENCY ONLY.**
- 2) QUOTATIONS RECEIVED OTHER THAN “INR” QUOTE SHALL SUMMARILY BE REJECTED.**
- 3) OFFERED PRICE SHOULD BE EXCLUSIVE OF APPLICABLE GST.**
- 4) PARTIAL OFFER IS NOT ACCEPTABLE. OFFER RECEIVED FOR THE PARTIAL ITEM SHALL BE SUMMARILY BE REJECTED**
- 5) RATE MENTIONED AS “0” IN PRICE SCHEDULE SHALL BE CONSIDERED AS “WITHOUT ANY CHARGE/ FREE OF COST”.**

Annexure – XIII
COMMERCIAL TERMS & CONDITIONS

IPR Enquiry/Tender No	IPR/TN/PUR/TPT/ET/21-22/043 dated 14/02/2022
Item Description	Design, Engineering, Assembly, Factory Acceptance Testing, and Supply, Installation, Commissioning and Site Acceptance Testing including Training of High Current Equilibrium Field Power Supply (EFPS) and its spares as per the detailed specifications mentioned in the tender documents

Sl. No.	PARTICULARS	REMARKS
I	Name of the Bidder	
II	Bidder Bid No & Date	
III	Postal address	
IV	Contact with STD code	
V	Fax with STD code	
VI	Name of Contact person	
VII	Mobile No.	
VIII	e-mail ID	
IX	Currency of offer/quotation	INR
Commercial Terms for Quoted items (Please Provide Commercial terms and conditions in the below form)		
1	Price Term for Supplies offered in Indian Currency	FOR IPR Gandhinagar
3	<p>Goods and Services Tax:</p> <p>Goods and Service Tax for Supply Items only: IPR is entitled to avail GST Concessional Rate as per Ministry of Finance Notification No. 47/2017 Integrated Tax (Rate) dated 14/11/17 (for IGST) and (CGST @ 2.5% and SGST @ 2.5%) as per Notification No. 45/2017-Central Tax (Rate) dated 14/11/17 and Notification No. 45/2017-State Tax (Rate) dated 15/11/17</p> <p>Confirm that in the event of issuance of GST Concessional Certificate you shall charge GST on Supply Portion @5% only</p> <p>Goods and Service Tax for Service items: As applicable</p>	
4	Delivery period: Refer tender terms	

5	Installation and commissioning charges: Have you offered Installation & Commissioning Charges? (if applicable)	
6	Liquidated Damages:- Please confirm that the Liquidated Damages as per Sr. No. 10 of Form No. IPR-P-100 attached with the tender/enquiry is acceptable to you	
7	Terms of Payment:- Please confirm payment terms mentioned in the tender document is acceptable to you Refer " Annexure-IV " for details	
8	Guaranty / Warranty:- Refer tender terms	
9	Validity of offer/quotation:- Refer tender terms	
	QUESTIONNAIRE TO BE FILLED BY BIDDER IN AND SENT ALONG WITH OFFER DULY SIGNED	Accepted/ Not Accepted
10	Performance Security: In the event of a purchase order/contract vendor has to provide Performance Security (PSDBG) as per tender terms, wherever applicable shall be submitted.	
11	Free Issue Material: Successful tenderer will have to arrange insurance/ Bank Guarantee towards adequate security for the materials/property provided/issued by the Purchaser as Free Issue Material for the due execution of the contract, wherever applicable.	

Yours faithfully
Bidder
(Digitally signed or ink signed)

SECTION 'D' :
TECHNICAL SPECIFICATIONS OF STORES
AND
DRAWINGS

Institute for Plasma Research

(An Aided Institute of Dept. of Atomic Energy)

Bhat, Gandhinagar

QUALIFYING REQUIREMENTS

ITEM DESCRIPTION	Design, Engineering, Assembly, Factory Acceptance Testing, and Supply, Installation, Commissioning and Site Acceptance Testing including Training of High Current Equilibrium Field Power Supply (EFPS) and its spares as per the detailed specifications mentioned in the tender documents	
Sr. No.	Detailed Criteria	Documents required to submit / upload
1	The bidder should have supplied/developed Passive Components or Power Supply for High Pulse Current rating (minimum 1 kA) in the last 10 years from the date of publication of this tender.	Bidder should upload copy of Purchase order/s along with documentary proof issued by the Purchaser in respect of completion of the order like Delivery Challan duly Signed by the purchaser/ Payment Receipt/ Work Completion Certificate/ Acceptance Tests Report
Note:		
a	The response to tender without submission of proof of above points will summarily be rejected without further communication	
b	The bidder shall not be under a declaration of ineligibility for corrupt or fraudulent practices or blacklisted with any of the Government agencies	
c	Original documents shall be produced for verifications, if required	

TECHNICAL SPECIFICATION
FOR
EQUILIBRIUM FIELD POWER SUPPLY (EFPS)



INSTITUTE FOR PLASMA RESEARCH
(An Aided Institute of Department of Atomic Energy, Government of India)

BHAT, GANDHINAGAR – 382 428
GUJARAT, INDIA

Contents

1. SCOPE OF SUPPLY.....	3
2. SCOPE OF WORK	3
3. TECHNICAL SPECIFICATIONS	4
4. ACCEPTANCE TESTING.....	7
5. CONTRACT MANAGEMENT.....	8
ANNEXURE-1: APPLICATION, SITE CONDITION & COIL PARAMETERS	11
ANNEXURE-2: EFPS CONCEPTUAL DESIGN & OUTPUT CURRENT WAVE PROFILE	12
ANNEXURE-3: GUARANTEED TECHNICAL PARTICULARS (GTP)	14

1. SCOPE OF SUPPLY

The scope of supply includes Design, Engineering, Assembly, Factory Acceptance Testing, and Supply, Installation and Site Acceptance Testing of High Current Equilibrium Field Power Supply (EFPS) and its spares at Institute for Plasma Research (IPR), Gandhinagar as per the detailed technical specification (including annexures) mentioned in this tender document.

2. SCOPE OF WORK

The scope of work includes, but not limited to, the following main tasks:

- a) Design of EFPS as per technical specifications specified in Section-4.
- b) Submission of detailed Engineering Design (including BOM), Layout Drawings and detailed Schedule as mentioned in Section-5 for IPR's review and approval.
- c) Procurement of all passive and active electrical components viz. Resistors, Inductors, Capacitors, Diodes, Bus-bars, Thyristors modules, End Terminations including Clamps & Connectors, fittings & accessories, etc. required as per technical specifications and as may be required for complete design and development of EFPS.
- d) Assembly/integration of procured components as per the approved design and drawings.
- e) Arrange the stage-wise inspections as per the agreed procedures.
- f) Perform the Factory Acceptance Tests (FAT) as per approved acceptance test procedure complying with the specifications as specified in Section-4.1
- g) Upon receipt of dispatch clearance note from IPR, Pack and Deliver the EFPS including dummy load and external coil at IPR site
- h) Unloading and Installation of EFPS (Refer Section-5).
- i) Perform the Site Acceptance Tests (SAT) as per Section-4.2.
- j) Provide operational and instruction manuals with full technical details. (Refer Section-5).
- k) Provide FAT and SAT reports with all test results, to the IPR before final acceptance.
- l) Provide technical support as per the warranty clause.

3. TECHNICAL SPECIFICATIONS

There are three major subsystems or parts of the EFPS, i.e. (i) Charging Power Supply, (ii) Capacitor Banks, (iii) Switching & Control Circuit. The technical requirements for overall system and each subsystem is mentioned in table-1. Please refer Annexure-1 for EFPS schematic & block diagram.

Table 1: Technical Specification of EFPS

Sr. No.	Parameter	IPR requirement
1.	EFPS Overall requirements	
a)	Rated Output Pulse Current	500 A to 5000 A
b)	Duty Cycle	0.5s-ON & 900s-OFF Continuous
c)	Polarity	Positive
d)	Size	~ 2m x 1.5m x 2m (L x W x H)
e)	Measurement	EFPS Output Voltage EFPS Output Current

2.	Capacitor Charging Power Supplies (CCPS)	Bank-1	Bank-2
a)	Peak Capacitor Charging Power	2.5 kJ/s	4 kJ/s
b)	Output Voltage Range	0.1kV - 7.2 kV	2V - 200V
c)	Output Current Range	0 - 700 mA	0-40 A
d)	Input Voltage	230 V ± 10 % AC, 50Hz	230 V ± 10 % AC, 50Hz
e)	Polarity	Positive	Positive
f)	Cooling	Forced Air	Forced Air
g)	Regulation	≤ 1 %	≤ 1 %
h)	Protection	a) Over Current b) Over Voltage c) Short Circuit d) Over Temperature	a) Over Current b) Over Voltage c) Short Circuit d) Over Temperature
i)	Control	a) On & OFF Switch b) HV on & off c) Voltage & Current Setting d) CC & CV Mode e) Local & Remote f) Fault Reset (OC/OV/OT)	a) On & OFF Switch b) Voltage & Current Setting c) CC & CV Mode d) Local & Remote e) Fault Reset (OC/OV/OT)
j)	Measurement & Display	a) Output Current b) Output Voltage c) On & Off Status display d) HV on & off e) CC & CV Mode display f) Fault Status g) Full Charge Indication Lamp	a) Output Current b) Output Voltage c) On & Off Status display d) CC & CV Mode display e) Fault Status f) Full Charge Indication Lamp
k)	Output Connection Cables	a) 5 meter connection HV cables for rated output specifications	a) 5 meter connection cables for rated output specifications
l)	Housing	19" rack is preferable for CCPS housing	19" rack is preferable for CCPS housing
m)	Earthing	Provision for earthing terminal	Provision for earthing terminal

3.	Capacitor Banks	Bank-1	Bank-2
a)	Type of Capacitor	DC-Link (Metallized Polypropylene) Capacitor	Super Capacitor
b)	Nominal Capacitance Value	~ 10mF With provision of tapping at for following capacitance values: a) 1mF b) 1.5mF c) 2.5mF d) 4.5mF e) 10mF	120 F ~140F (Standard OEM Modules shall be preferred to achieve the final capacitance values)
c)	Rated Voltage V	≥ 7200 V	≥ 192 V
d)	Capacitance Tolerance	± 10%	± 10%
e)	Peak Rated Current (for 0.5s)	Suitable for 5 kA dc current, consider all de-rating factors & safety margins.	Suitable for 5 kA dc current, consider all de-rating factors & safety margins.
f)	Maximum Operating Temperature	~65 °C	~65 °C
g)	Protection/Safety	a) Discharge Switch with interlock (*Capacitor Bank can be accessed after fully discharge only) b) Access protection through timer and voltage measurement across capacitor bank c) Protection Diode to avoid reverse charging d) Discharge Switch Status display e) Access Protection Status display f) Full Discharge indication lamp with redundancy g) Full Charge Indication Lamp	a) Discharge Switch with interlock (*Capacitor Bank can be accessed after fully discharge only) b) Access protection through timer and voltage measurement across capacitor bank c) Protection Diode to avoid reverse charging d) Discharge Switch Status display e) Access Protection Status display f) Full Discharge indication lamp with redundancy g) Full Charge Indication Lamp
h)	Housing for Module	a) Dust, Water & Shock proof b) Heavy duty metal housing c) Earthing terminal provision in case of metallic housing	a) Dust, Water & Shock proof b) Heavy duty metal housing c) Earthing terminal provision in case of metallic housing
i)	Terminal Marking and connection	Positive & Negative terminal marking and suitable hardware to avoid reverse polarity connections.	Positive & Negative terminal marking and suitable hardware to avoid reverse polarity connections.
j)	Connecting Cables	~5 meter cable for output connections. (a) Rated Current ≥ 5 kA for 1s (b) Rated Voltage ≥ 7.5 kV DC	~5 meter cable for output connections. (a) Rated Current ≥ 5 kA for 1s (b) Rated Voltage ≥ 1.1 kV DC

4.	Switching & Control Circuit		
a)	Switch	Thyristor or Thyristor Module	
b)	Maximum Average(D.C.) On-State Current for 500ms	Suitable for 5 kA dc current, consider all de-rating factors & safety margins.	
c)	i) Repetitive Peak Off-State	≥ 7.5 kV	

	Voltage ii) Repetitive Peak Reverse Voltage	≥ 7.5 kV
d)	Commutation	Force Commutation Note: Free Wheeling Diode shall be provided at output to free-wheel the current during commutation. There should be provision for snubber circuit for diode protection if required.
e)	Protection	Suitable Thermal Protection shall be considered for Switching Circuit.
f)	Control & Display (Master Control Panel)	Programmable Controller for complete operation and control with suitable color touch screen User Interface i. Provision for programming of timings for triggering pulses of switching & commutation Thyristors via user interface. ii. Thyristor Firing Pulse Start Push Button to start the operation. iii. Capacitor Bank Discharge Switch On-Off Control & Status iv. Setting of Control parameters of CCPS mentioned in 2-i section. v. Measurement and Display of CCPS parameters mentioned in 2-j section. vi. Facility to save EFPS Output Current & Voltage profiles vii. Graphical display of coil output voltage and current on UI viii. PC Interface for data download via ethernet or equivalent. ix. Display of Capacitor Bank Voltage x. Full Charge and Discharge Status display of Capacitor Banks. xi. Access protection through timer and voltage measurement (Ref. 3-g section) xii. Access Protection Status
g)	Housing	i. Switching Circuit, Commutation Circuit & Control Circuit shall be assembled in appropriate panels. ii. Panels should have input and output termination of the rated capacity and with easy of connectivity. iii. Panels shall be fabricated from suitable material considering appropriate thickness. iv. The doors and removable covers shall be provided with neoprene gaskets to make the panel dust and vermin proof. v. Panel shall be properly powder coated.
h)	Connecting Cables	10 meter cable of suitable rating for output connection.

5.	Remote Signals	<p>Following functionalities shall be available via Ethernet: Open industrial communication protocol shall be considered for Ethernet</p> <p>A. From CCPS (Bank-1) :</p> <p>a) CCPS On/Off Control b) CCPS HV On-OFF Control c) CCPS Output Current & Voltage setting d) CC & CV Mode Selection e) Fault Reset(OV/OC/OT) f) ON-OFF Status Display g) CC & CV Mode Status h) Output Current & Voltage Display i) HV ON/OFF Status (For Bank-1 only) j) Fault Status(OV/OC/OT)</p> <p>B. From Capacitor Bank (Bank-1) :</p>	<p>Following functionalities shall be available via Ethernet: Open industrial communication protocol shall be considered for Ethernet</p> <p>A. From CCPS (Bank-2) :</p> <p>a) CCPS On/Off Control b) CCPS Output Current & Voltage setting c) CC & CV Mode Selection d) Fault Reset(OV/OC/OT) e) ON-OFF Status Display f) CC & CV Mode Status g) Output Current & Voltage Display h) HV ON/OFF Status (For Bank-1 only) i) Fault Status(OV/OC/OT)</p> <p>B. From Capacitor Bank (Bank-2):</p> <p>a) Charging Voltage Display b) Discharge switch status</p>
-----------	-----------------------	--	---

		a) Charging Voltage Display b) Discharge switch status c) Access Control Inter-lock Status d) Full Charge & Discharge Indication lamp Display C. From Switching & Control Circuit a) Thyristor Firing Pulse start operation Control (it shall be provided via optical fibre with suitable isolation with transmitter and receiver) b) Thyristor Switching Programming Control (And other signals which may be required for the complete remote operation)	c) Access Control Inter-lock Status d) Full Charge & Discharge Indication lamp Display C. From Switching & Control Circuit a) Thyristor Firing Pulse start operation Control (it shall be provided via optical fibre with suitable isolation transmitter and receiver) b) Thyristor Switching Programming Control (And other signals which may be required for the complete remote operation)
--	--	--	--

6.	Dummy Load	a) Rated DC Pulse Current : 5000 A b) Rated Voltage : 6 kV c) Coil Resistance & Inductance: R = 8.22 mΩ, L = 0.110 mH d) Tolerance : ± 10% e) Pulse Duration :100 ms f) Enclosure with suitable isolation and feed-through shall be provided for connection. g) Free-wheeling diode with suitable rating shall be provided. The snubber circuit for diode shall be provide if required.
-----------	-------------------	---

7.	External Coil	a) Rated DC Pulse Current : 5000 A b) Rated Voltage : 8 kV c) Coil Resistance & Inductance: R = 20 mΩ, L = 2 mH d) Tolerance : ± 10% e) Pulse Duration :100 ms f) Enclosure with suitable isolation and feed-through shall be provided for connection.
-----------	----------------------	--

4. ACCEPTANCE TESTING

4.1. Factory Acceptance Tests:

The following are some major tests that are to be performed by the supplier to demonstrate compliance with the EFPS as per the contract specifications before the shipment. All the related test equipment, fixtures, measuring instruments, test-setup, test load, etc., shall be arranged by the supplier. Supplier shall submit a FAT template to IPR for review and approval. The details of the test template and testing procedure shall be done on the mutual agreement after the award of the contract. IPR representative shall witness the FAT at the manufacturer's works.

The tests not mentioned below, but required to validate the performance/ characterization of EFPS as per specification shall be included and performed by the bidder.

- a) Visual inspection of EFPS (including its accessories and discrete components)
- b) Review of test certificates of all bought-out items.
- c) Tests & Measurement for qualification on key active and passive components viz. Capacitors (20% of total quantity selected as samples), inductors.
- d) Demonstration of minimum 10 shots of typical Output Current up to 5kA for 100ms pulse with external coil and the dummy load in local & remote mode.

The tests result of any component of EFPS if found unsatisfactory to the purchaser; the same shall be properly rectified and tested again to the satisfaction of the purchaser by the bidder at no extra cost. The detailed test report including the test results shall be prepared by the supplier and submitted to the purchaser for approval/ acceptance for dispatch clearance. After the review and approval of the FAT report, a Dispatch Clearance Note shall be issued to the supplier by IPR. All the deliverables (hardware and documents) shall be dispatched only after receiving a dispatch clearance note from IPR.

4.2. Site Acceptance Tests:

After the installation of EFPS at the IPR site, the SAT shall be performed by the supplier. Site acceptance tests shall include but not limited to the following tests:

- a) Demonstration of minimum 10 shots of typical Output Current up to 5kA for 100ms pulse with the supplied dummy load in local & remote mode.

After the completion of SAT, the detailed test report including the test results shall be prepared by the supplier. The representative IPR and Supplier shall jointly sign the SAT reports.

5. CONTRACT MANAGEMENT

5.1. DESIGN AND DRAWINGS SUBMISSION:

[1] ALONG WITH BID SUBMISSION:

The Bidder shall submit the following minimum documents (but not limited to) along with the bid.-

- a) Electrical schematic drawings & block diagrams.
- b) Bill of materials (BOM) for major components.
- c) Datasheets of major components of EFPS.

[2] AFTER AWARD OF PURCHASE ORDER:

After the award of the purchase order/contract, the supplier should submit within 21 days the engineering Design and layout Drawings for the EFPS based on the technical proposal submitted during the bid for IPR approval. Bidder shall start manufacturing/developing the power supply only after getting approval from IPR. This report shall include the following minimum submission documents (but not limited to) -

- a) Engineering design and drawings including GA drawings and electrical schematic drawings.
- b) List of all accessories, hardware, and bill of materials (BOM).
- c) Datasheets of all the bought-out major components viz. Super Capacitors, Thyristors, current/voltage measuring sensors, protective Elements, etc. used for making of EFPS shall be provided.
- d) A stage-wise inspection procedures (QAP) which ensures the quality of the deliverables items under this contract.

5.2. Operating and Instruction Manual:

The supplier shall submit 3 sets of document / technical literature in the English language with complete layout, GA Drawings, detailed block diagrams, and circuit diagrams of its assembly. All aspects of installation, operation, maintenance, and troubleshooting instructions as specified below shall be covered in this manual.

- a) Safety measures to be observed in the handling of the equipment.
- b) Precautions at the time of installation, operation, and maintenance.
- c) Procedures for troubleshooting the faults, replacement, and routine/preventive maintenance.
- d) Test instruments, test fixtures, accessories, and tools required for maintenance and repair.
- e) List of replaceable parts used with the sources of procurement.

f) Guidelines for the off-line and on-line maintenance of super capacitors.

5.3. Material Dispatch/Packing and Delivery:

After the review and approval of the FAT report, a Dispatch Clearance Note shall be issued to the supplier by IPR. All the deliverables (hardware and documents) shall be dispatched only after receiving a dispatch clearance note from IPR. However, a mere clearance issued by IPR will not relieve the supplier from the liability of proper functioning of EFPS at IPR.

Appropriate safe packing, transportation (including Insurance) to the IPR site is under the scope of the supplier, which shall include (but not limited to) a necessary list of documentation and appropriate packing, markings, labeling for the deliverables items. It must be noted that IPR shall not be liable for any of the damages caused during transit of the deliverables. The detailed packaging and transportation scheme shall be submitted to IPR well in advance.

5.4. Site Description:

The delivery site is located in the **Institute for Plasma Research Campus, Near Indira Bridge, Bhat, Gandhinagar – 382 428, Gujarat, India**. Space, where the EFPS unit is to be installed is situated at ground floor level in IPR New Laboratory Building.

5.5. Unloading and Storage:

Bidder is responsible for the unloading of the EFPS and accessories at proper locations at the site and verification of unit for damages and short supplies, making good all such damages and short supplies. The EFPS shall be stored at Bidder's responsibility until final acceptance and taking over by IPR.

5.6. Installation & commissioning:

Bidder is responsible for the installation of the following items-

- EFPS and its accessories.

Any material or accessory which may not have been specifically mentioned but which is necessary shall be supplied at no extra cost to IPR. ***The installation should be completed within 15 days after the material is delivered to the site.***

5.7. Final Acceptance:

A final acceptance note shall be issued by IPR to the supplier after successful completion of SAT (and after resolving issues completely, if any) at site and submission of "As-built" marked-up drawings incorporating all modifications/changes made during manufacturing, testing, and installation of the EFPS. The date of issuance of the final acceptance note shall be considered as the date of final acceptance.

5.8. Training:

The supplier has to arrange technical training of a minimum of one representative from IPR at the IPR site to familiarize themselves with various sub-systems, operation, and maintenance of EFPS.

5.9. Warranty:

The supplied Power Supply and its sub-systems & accessories shall cover a warranty period of 12 months from the date of final acceptance at IPR site for any assembly, operational or manufacturing defects.

5.10. Delivery Schedule

Submission of Design Documents & Quality Assurance Plan (QAP) for IPR Approval within one month from the PO date. Final Acceptance of EFPS shall be within 10 months from the approval of design documents.

Sr. No.	Time	Milestone
1.	T0	Purchase Order Date

2.	T1= T0 + 21 days	Submission of Design Documents & Quality Assurance Plan (QAP) for IPR Approval
3.	T2= T1 + 30 days	Approval of Design Documents & QAP by IPR
4.	T3= T2 + 240 days	Factory Acceptance Test, Dispatch Clearance and Delivery at IPR
5.	T4= T3 + 30 days	Installation, Commissioning, Site Acceptance Test & Training
6.	T5= T4 + 30 days	Final Acceptance

ANNEXURE-1: APPLICATION, SITE CONDITION & COIL PARAMETERS

A. APPLICATION DESCRIPTION

Equilibrium Field (EF) coils are required for shaping and control of the plasma in a Tokamak. EF coils have various roles in a Tokamak. The EF coils provide the required vertical field during the discharge to prevent the plasma column from expanding to the vessel walls.

B. SITE CONDITIONS

Ambient Temperature (maximum/minimum/average (annual))	47 °C / 4 °C / 35 °C
Relative Humidity (maximum / minimum)	90 % / 17 %
Altitude	55 meters above MSL
Installation	Indoor

C. EF COIL PARAMETERS AND REQUIREMENTS

Sr.No.	Parameters/Requirements	Values
1.	Coil Resistance	8.22 mΩ
2.	Coil Inductance	110μH
3.	Required Coil Current	4.5 kA
4.	Maximum allowed Coil Current	5 kA
5.	Insulation break down voltage	(a) Inter-turn : 1.5kV (b) Outer Insulation : 6kV
6.	Rise Rate	1 - 3 MA/s (Variable)
7.	Variation in Current Droop for time duration of 50ms	Variable (10% to 50%)
8.	Current Variation	Flexibility in Coil Peak Current Value

ANNEXURE-2: EFPS CONCEPTUAL DESIGN & OUTPUT CURRENT WAVE PROFILE

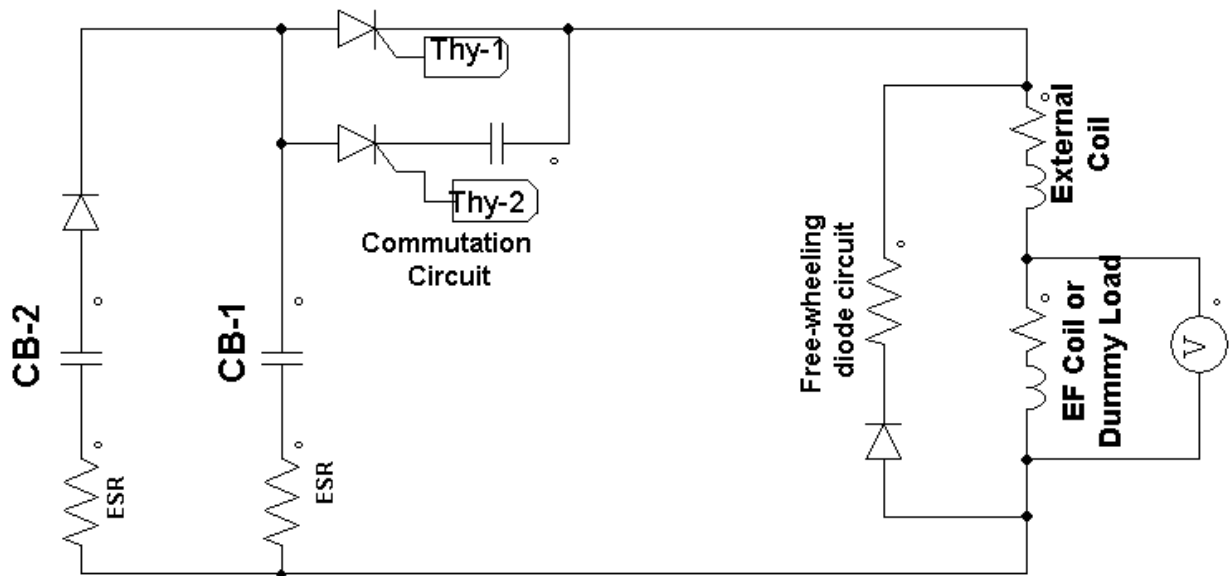

Figure 1: Schematic of EFPS DC Power Supply

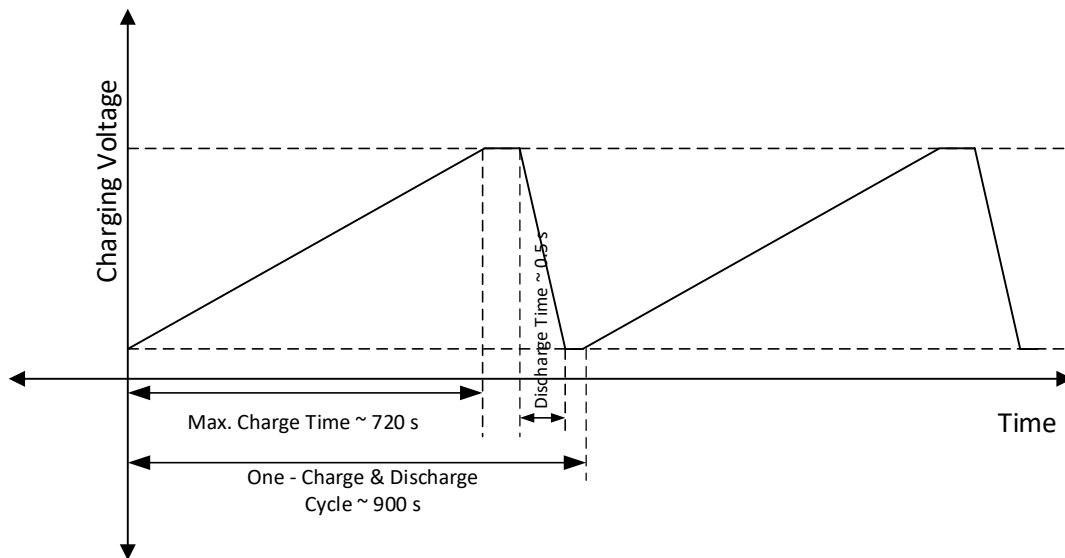

Figure 2: Capacitor bank charge & discharge waveshape (CCPS)

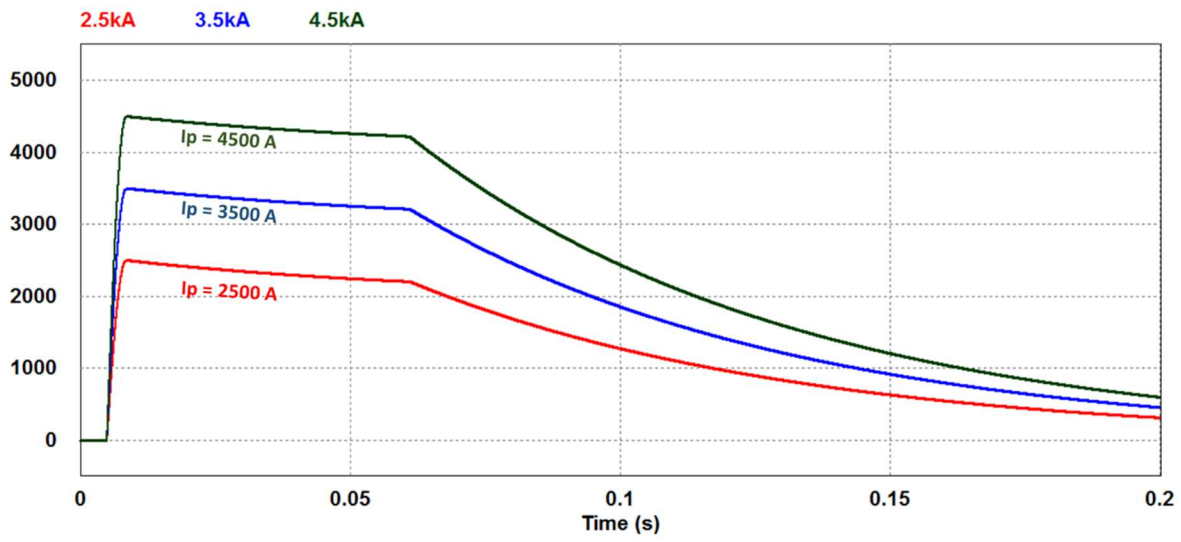

Figure 3: Sample Output Current Profiles of EFPS

ANNEXURE-3: GUARANTEED TECHNICAL PARTICULARS (GTP)

Bidder must submit the GTP along with the following documents –

- a) Electrical schematic drawings & block diagrams.
- b) Bill of materials (BOM) for major components.
- c) Datasheets of major components of EFPS.

Note: Guaranteed Technical Particulars sheet shall be duly filled in with required data or numbers against each parameter.

Sr. No.	Parameter	IPR requirement	Bidder's Specifications
1.	EFPS Overall requirements		
a)	Rated Output Pulse Current	500 A to 5000 A	
b)	Duty Cycle	0.5s-ON & 900s-OFF Continuous	
c)	Polarity	Positive	
d)	Size	~ 2m x 1.5m x 2m (L x W x H)	
e)	Measurement	EFPS Output Voltage EFPS Output Current	

2.	Capacitor Charging Power Supplies (CCPS)	Bank-1	Bank-2	Bidder's Specifications
a)	Peak Capacitor Charging Power	2.5 kJ/s	4 kJ/s	
b)	Output Voltage Range	0.1kV - 7.2 kV	2V - 200V	
c)	Output Current Range	0 -700 mA	0-40 A	
d)	Input Voltage	230 V ± 10 % AC, 50Hz	230 V ± 10 % AC, 50Hz	
e)	Polarity	Positive	Positive	
f)	Cooling	Forced Air	Forced Air	
g)	Regulation	≤ 1 %	≤ 1 %	
h)	Protection	a) Over Current b) Over Voltage c) Short Circuit d) Over Temperature	a) Over Current b) Over Voltage c) Short Circuit d) Over Temperature	
i)	Control	a) On & OFF Switch b) HV on & off c) Voltage & Current Setting d) CC & CV Mode e) Local & Remote f) Fault Reset (OC/OV/OT)	a) On & OFF Switch b) Voltage & Current Setting c) CC & CV Mode d) Local & Remote e) Fault Reset (OC/OV/OT)	
j)	Measurement & Display	a) Output Current b) Output Voltage c) On & Off Status display d) HV on & off e) CC & CV Mode display f) Fault Status g) Full Charge Indication Lamp	a) Output Current b) Output Voltage c) On & Off Status display d) CC & CV Mode display e) Fault Status f) Full Charge Indication Lamp	

k)	Output Connection Cables	a) 5 meter connection HV cables for rated output specifications	a) 5 meter connection cables for rated output specifications	
l)	Housing	19" rack is preferable for CCPS housing	19" rack is preferable for CCPS housing	
m)	Earthing	Provision for earthing terminal	Provision for earthing terminal	

3.	Capacitor Banks	Bank-1	Bank-2	
a)	Type of Capacitor	DC-Link (Metallized Polypropylene) Capacitor	Super Capacitor	
b)	Nominal Capacitance Value	~ 10mF With provision of tapping at for following capacitance values: a) 1mF b) 1.5mF c) 2.5mF d) 4.5mF e) 10mF	120 F ~140F (Standard OEM Modules shall be preferred to achieve the final capacitance values)	
c)	Rated Voltage V	≥ 7200 V	≥ 192V	
d)	Capacitance Tolerance	± 10%	± 10%	
e)	Peak Rated Current (for 0.5s)	Suitable for 5 kA dc current, consider all de-rating factors & safety margins.	Suitable for 5 kA dc current, consider all de-rating factors & safety margins.	
f)	Maximum Operating Temperature	~65 °C	~65 °C	
g)	Protection/Safety	a) Discharge Switch with interlock (*Capacitor Bank can be accessed after fully discharge only) b) Access protection through timer and voltage measurement across capacitor bank c) Protection Diode to avoid reverse charging d) Discharge Switch Status display e) Access Protection Status display f) Full Discharge indication lamp with redundancy g) Full Charge Indication Lamp	a) Discharge Switch with interlock (*Capacitor Bank can be accessed after fully discharge only) b) Access protection through timer and voltage measurement across capacitor bank c) Protection Diode to avoid reverse charging d) Discharge Switch Status display e) Access Protection Status display f) Full Discharge indication lamp with redundancy g) Full Charge Indication Lamp	
h)	Housing for Module	a) Dust, Water & Shock proof b) Heavy duty metal housing c) Earthing terminal provision in case of metallic housing	a) Dust, Water & Shock proof b) Heavy duty metal housing c) Earthing terminal provision in case of metallic housing	

i)	Terminal Marking and connection	Positive & Negative terminal marking and suitable hardware to avoid reverse polarity connections.	Positive & Negative terminal marking and suitable hardware to avoid reverse polarity connections.	
j)	Connecting Cables	~5 meter cable for output connections. (a) Rated Current ≥ 5 kA for 1s (b) Rated Voltage ≥ 7.5 kV DC	~5 meter cable for output connections. (a) Rated Current ≥ 5 kA for 1s (b) Rated Voltage ≥ 1.1 kV DC	

4.	Switching & Control Circuit			
a)	Switch	Thyristor or Thyristor Module		
b)	Maximum Average(D.C.) On-State Current for 500ms	Suitable for 5 kA dc current, consider all derating factors & safety margins.		
c)	iii) Repetitive Peak Off-State Voltage	≥ 7.5 kV		
	iv) Repetitive Peak Reverse Voltage	≥ 7.5 kV		
d)	Commutation	Force Commutation Note: Free Wheeling Diode shall be provided at output to free-wheel the current during commutation. There should be provision for snubber circuit for diode protection if required.		
e)	Protection	Suitable Thermal Protection shall be considered for Switching Circuit.		
f)	Control & Display (Master Control Panel)	<p>Programmable Controller for complete operation and control with suitable color touch screen User Interface</p> <ul style="list-style-type: none"> i. Provision for programming of timings for triggering pulses of switching & commutation Thyristors via user interface. ii. Thyristor Firing Pulse Start Push Button to start the operation. iii. Capacitor Bank Discharge Switch On-Off Control & Status iv. Setting of Control parameters of CCPS mentioned in 2-i section. v. Measurement and Display of CCPS parameters mentioned in 2-j section. vi. Facility to save EFPS Output Current & Voltage profiles vii. Graphical display of coil output voltage and current on UI viii. PC Interface for data download via ethernet or equivalent. ix. Display of Capacitor Bank Voltage x. Full Charge and Discharge Status display of Capacitor Banks. xi. Access protection through timer and voltage measurement (Ref. 3-g section) xii. Access Protection Status 		
g)	Housing	i. Switching Circuit, Commutation Circuit & Control Circuit shall be assembled in		

		<p>appropriate panels.</p> <p>ii. Panels should have input and output termination of the rated capacity and with easy of connectivity.</p> <p>iii. Panels shall be fabricated from suitable material considering appropriate thickness.</p> <p>iv. The doors and removable covers shall be provided with neoprene gaskets to make the panel dust and vermin proof.</p> <p>v. Panel shall be properly powder coated.</p>	
h)	Connecting Cables	10 meter cable of suitable rating for output connection.	

5.	Remote Signals	<p><u>Following functionalities shall be available via Ethernet:</u> Open industrial communication protocol shall be considered for Ethernet</p> <p><u>A. From CCPS (Bank-1):</u></p> <p>a) CCPS On/Off Control</p> <p>b) CCPS HV On-OFF Control</p> <p>c) CCPS Output Current & Voltage setting</p> <p>d) CC & CV Mode Selection</p> <p>e) Fault Reset(OV/OC/OT)</p> <p>f) ON-OFF Status Display</p> <p>g) CC & CV Mode Status</p> <p>h) Output Current & Voltage Display</p> <p>i) HV ON/OFF Status (For Bank-1 only)</p> <p>j) Fault Status(OV/OC/OT)</p> <p><u>B. From Capacitor Bank (Bank-1):</u></p> <p>a) Charging Voltage Display</p> <p>b) Discharge switch status</p> <p>c) Access Control Inter-lock Status</p> <p>d) Full Charge & Discharge Indication lamp Display</p> <p><u>C. From Switching & Control Circuit</u></p> <p>a) Thyristor Firing Pulse start operation</p>	<p><u>Following functionalities shall be available via Ethernet:</u> Open industrial communication protocol shall be considered for Ethernet</p> <p><u>A. From CCPS (Bank-2):</u></p> <p>a) CCPS On/Off Control</p> <p>b) CCPS Output Current & Voltage setting</p> <p>c) CC & CV Mode Selection</p> <p>d) Fault Reset(OV/OC/OT)</p> <p>e) ON-OFF Status Display</p> <p>f) CC & CV Mode Status</p> <p>g) Output Current & Voltage Display</p> <p>h) HV ON/OFF Status (For Bank-1 only)</p> <p>i) Fault Status(OV/OC/OT)</p> <p><u>B. From Capacitor Bank (Bank- 2):</u></p> <p>a) Charging Voltage Display</p> <p>b) Discharge switch status</p> <p>c) Access Control Inter-lock Status</p> <p>d) Full Charge & Discharge Indication lamp Display</p> <p><u>C. From Switching & Control Circuit</u></p> <p>a) Thyristor Firing Pulse start operation Control (it shall be</p>	
----	----------------	--	---	--

		Control (it shall be provided via optical fibre with suitable isolation with transmitter and receiver) b) Thyristor Switching Programming Control (And other signals which may be required for the complete remote operation)	provided via optical fibre with suitable isolation transmitter and receiver) b) Thyristor Switching Programming Control (And other signals which may be required for the complete remote operation)	
6.	Dummy Load	a) Rated DC Pulse Current : 5000 A b) Rated Voltage : 6 kV c) Coil Resistance & Inductance: R = 8.22 mΩ, L = 0.110 mH d) Tolerance : ± 10% e) Pulse Duration :100 ms f) Enclosure with suitable isolation and feed-through shall be provided for connection. g) Free-wheeling diode with suitable rating shall be provided. The snubber circuit for diode shall be provide if required.		
7.	External Coil	a) Rated DC Pulse Current : 5000 A b) Rated Voltage : 8 kV c) Coil Resistance & Inductance: R = 20 mΩ, L = 2 mH d) Tolerance : ± 10% e) Pulse Duration :100 ms f) Enclosure with suitable isolation and feed-through shall be provided for connection.		
8.	FATs (Factory Acceptance Tests) (Please Refer section 4.1)	a) Visual inspection of EFPS (including its accessories and discrete components) b) Review of test certificates of all bought-out items. c) Tests & Measurement for qualification on key active and passive components viz. Capacitors (20% of total quantity selected as samples), inductors. d) Demonstration of minimum 10 shots of typical Output Current up to 5kA for 100ms pulse with supplied external coil and the dummy load in local & remote mode.		
9.	SATs (Site Acceptance Tests) (Please refer section 4.2)	a) Demonstration of minimum 10 shots of typical Output Current up to 5kA for 100ms pulse with the supplied external coil & dummy load in local & remote mode at IPR site.		
10.	Warranty	The supplied Power Supply and its sub-systems & accessories shall cover a warranty period of 12 months from the date of final acceptance at IPR site for any assembly, operational or manufacturing defects.		

Name and Singnature of Authorized Signatory

Official Seal with Date

SECTION 'E':

PRICE SCHEDULE

[Validate](#)[Print](#)[Help](#)

Item Rate BoQ

Tender Inviting Authority: Head-Purchase Section

Name of Work: Design, Engineering, Assembly, Factory Acceptance Testing, and Supply, Installation, Commissioning and Site Acceptance Testing including Training of High Current Equilibrium Field Power Supply (EFPS) and its spares as per the detailed specifications mentioned in the tender documents

Tender No: IPR/TN/PUR/TPT/ET/21-22/043 DATED 14/02/2022

PRICE SCHEDULE						
(This BOQ template must not be modified/replaced by the bidder and the same should be uploaded after filling the relevent columns, else the bidder is liable to be rejected for this tender. Bidders are allowed to enter the Bidder Name and Values only)						
NUMBER #	TEXT #	NUMBER #	TEXT #	NUMBER #	NUMBER #	TEXT #
Sl. No.	Item Description	Quantity	Units	BASIC RATE In Figures To be entered by the Bidder in Rs. P	TOTAL AMOUNT Without Taxes in Rs. P	TOTAL AMOUNT In Words
1	2	4	5	13	53	55
1	Design, Engineering, Assembly, Factory Acceptance Testing, and Supply, Installation and Site Acceptance Testing including Training of High Current Equilibrium Field Power Supply (EFPS) and its spares as per the detailed specifications mentioned in the tender documents					
1.01	Design, Engineering, Assembly, Factory Acceptance Testing, and Supply including unloading of High Current Equilibrium Field Power Supply (EFPS) and its spares as per the detailed specifications mentioned in the tender documents	1.000	Nos		0.00	INR Zero Only
1.02	Installation, Site Acceptance Testing and Training of High Current Equilibrium Field Power Supply (EFPS) and its spares as per the detailed specifications mentioned in the tender documents	1.000	Job		0.00	INR Zero Only
Total in Figures					0.00	INR Zero Only

Quoted Rate in Words

INR Zero Only