

NUCLEAR POWER GENERATION & SAFETY FEATURES

Rajeev Dhami
Scientific Officer/ Grade G, KAPP-3&4

17 th April, 2015

Kakrapar Gujarat Site
Nuclear Power Corporation Of India Limited (A Government of India Enterprise)

How is Electric Energy Produced?

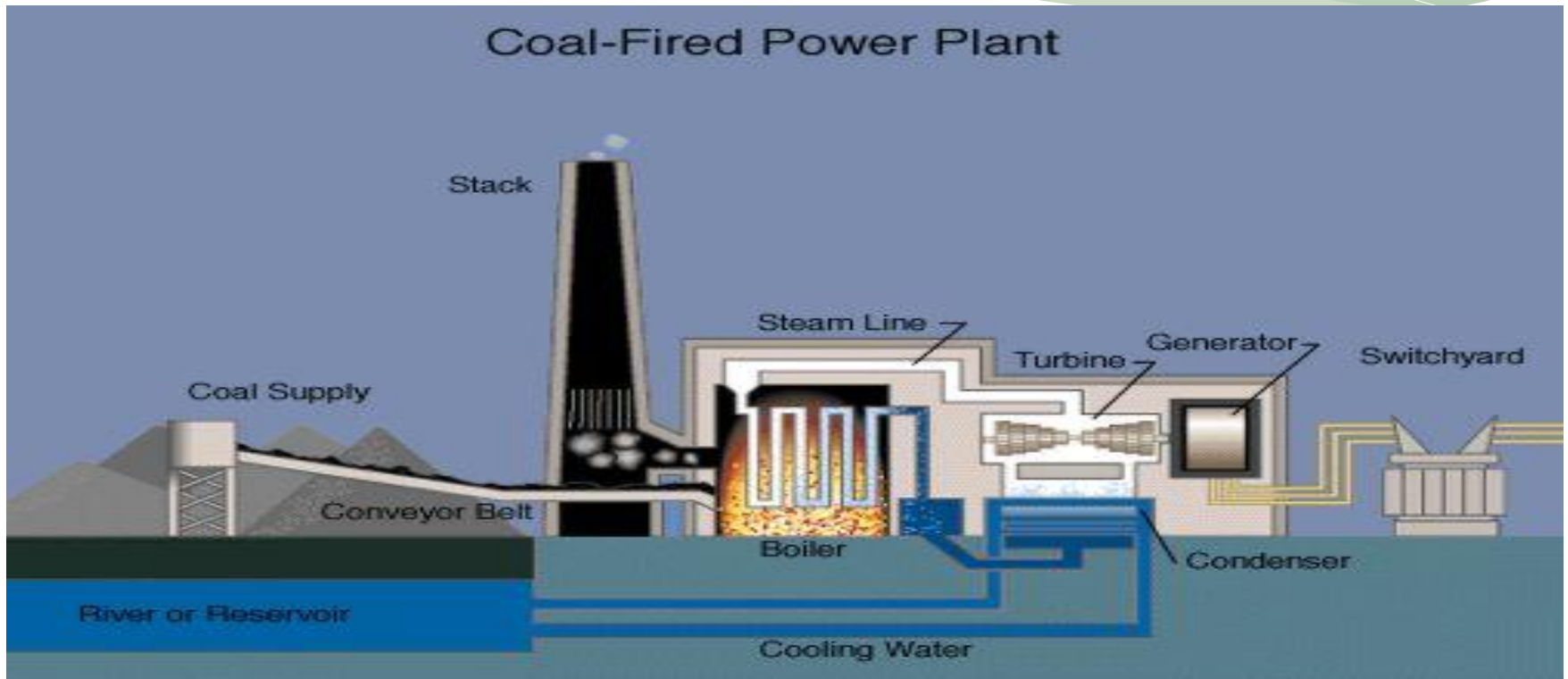

In Thermal power plants - By burning fossil fuels like oil, gas or coal in a boiler. Steam produced in the boiler is used to rotate the turbine and generator which produces electricity.

How is Electric Energy Produced?

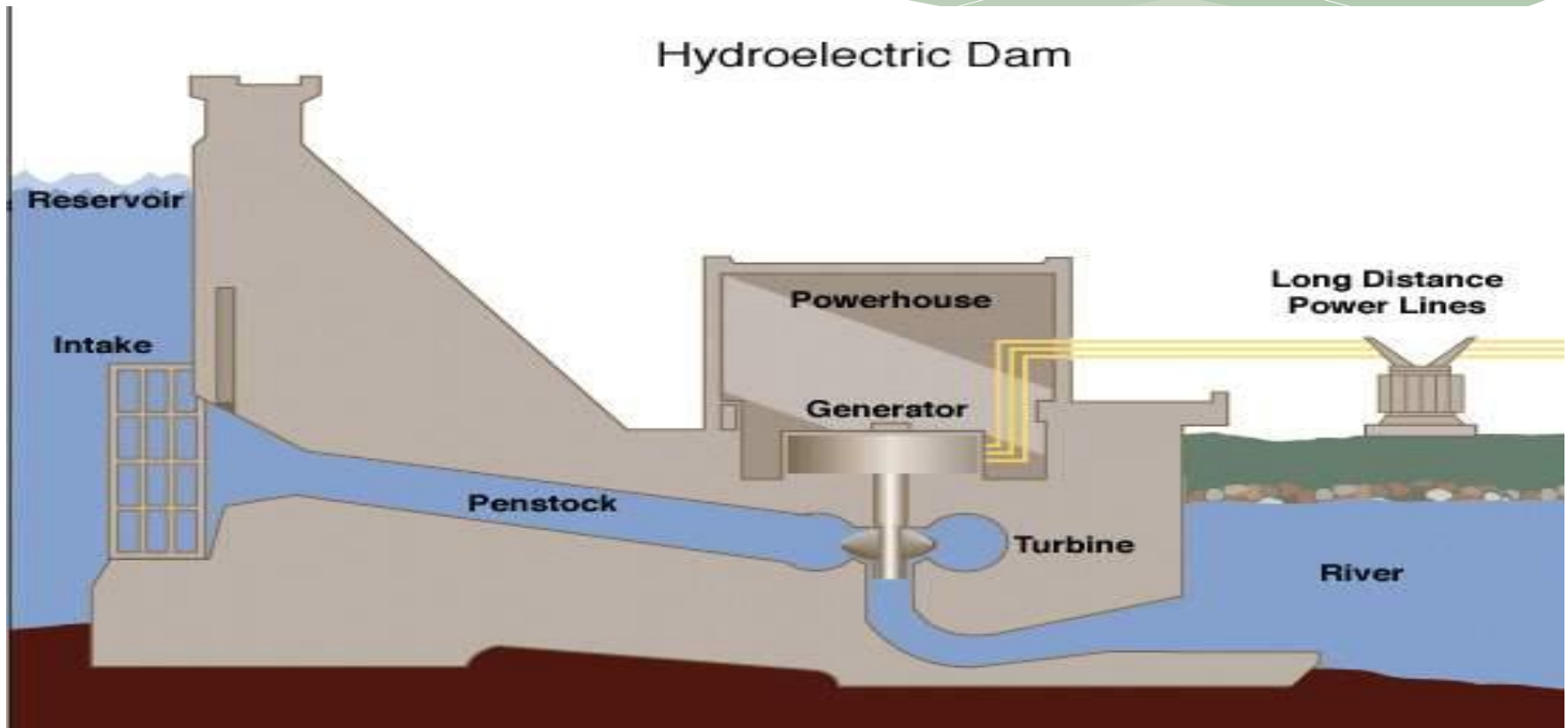

In a hydroelectric turbine, flowing (or falling) water pushes against the turbine blades, causing the rotor to spin, turning the copper armature inside the generator and generating an electric current.

How is Electric Energy Produced?



In a nuclear power plant, Heat Energy is produced inside a Reactor by the fission process of fissile atoms like Uranium-235, Plutonium-239 etc. This heat is used to turn water into steam, that, which in turn, spins a turbine that generates electricity.

How is Electric Energy Produced?



Electric energy is also produced by the conversion of the energy contained in wind into electricity using wind mill. In a wind mill , the wind spins the turbine rotor turning the copper armature inside the generator and generating an electric current.

Nuclear power plants- present status

Units under operation	Capacity (MWe)
TAPS-1, Maharashtra	160
TAPS-2, Maharashtra	160
RAPS-2, Rajasthan	200
MAPS-1, Tamilnadu	220
MAPS-2, Tamilnadu	220
NAPS-1, Uttar Pradesh	220
NAPS-2, Uttar Pradesh	220
KAPS-1, Gujrat	220
KAPS-2, Gujrat	220
KAIGA-2, Karnataka	220
RAPS-3, Rajasthan	220
KAIGA-1, Karnataka	220
RAPS-4, Rajasthan	220
TAPS-4, Maharashtra	540
TAPS-3, Maharashtra	540
KAIGA-3, Karnataka	220
KAIGA-4, Karnataka	220
RAPS-5, Rajasthan	220
RAPS-6, Rajasthan	220
KKNPP-1, Tamilnadu	1000

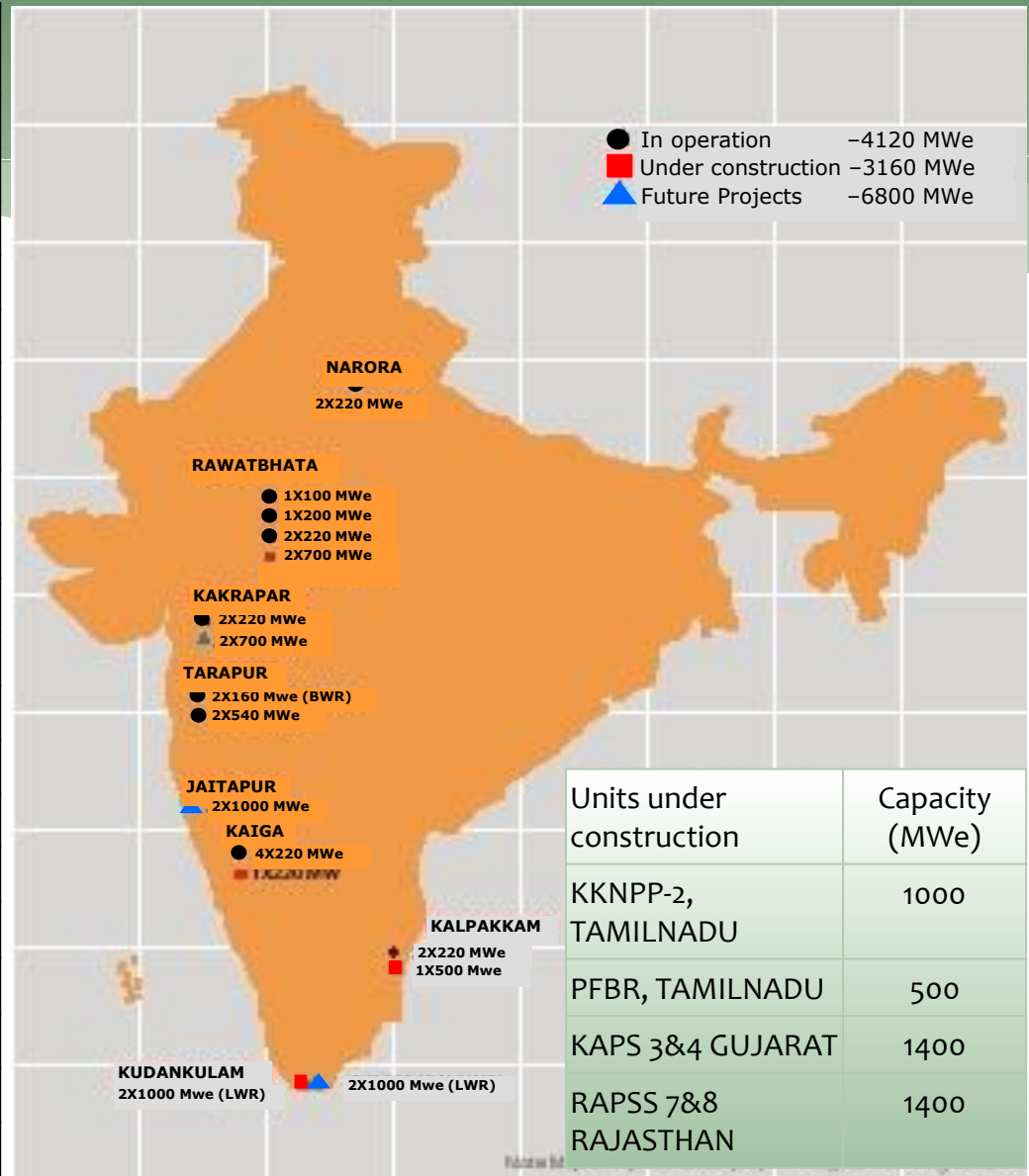

Kakrapar Atomic Power Station

- * **KAPS is indigenously built Pressurised Heavy Water Reactor (PHWR) with installed capacity of 2 X 220 MWe each.**
- * **Under expansion program two more Units of 2 X 700 MWe PHWR units are being constructed at this site.**

Steam Generation using Nuclear Heat

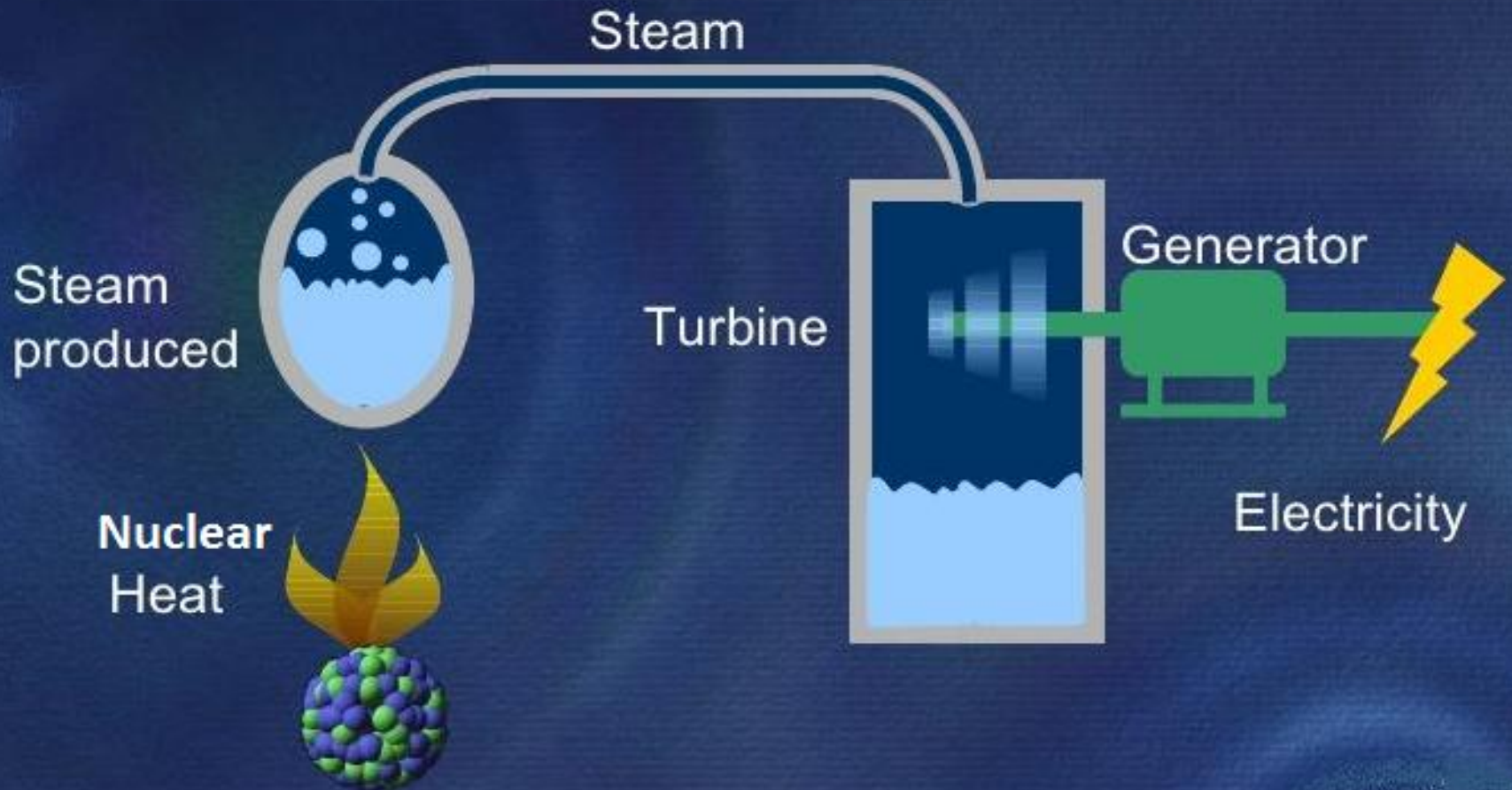

Nuclear Energy Comes From Fission

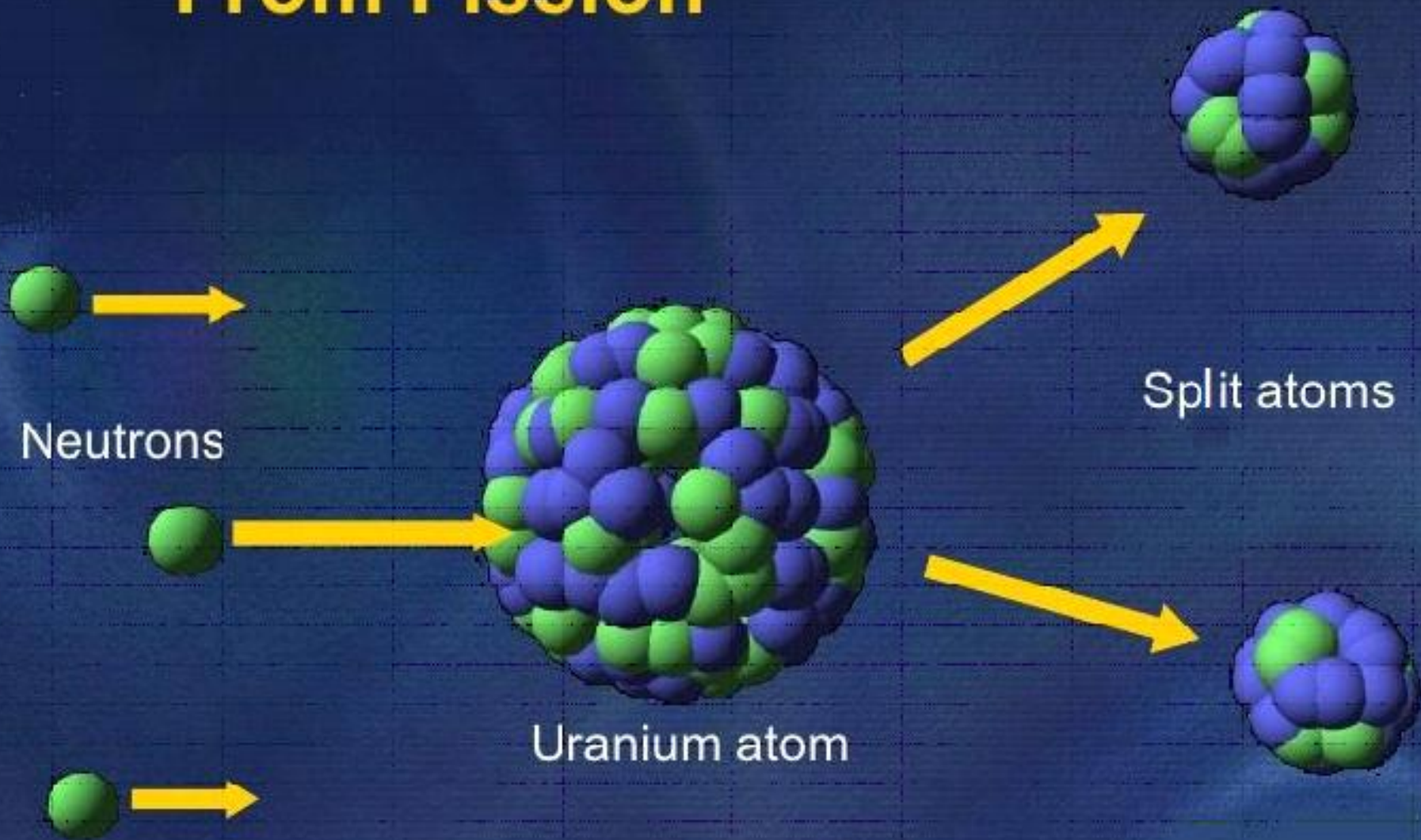

Splitting Atoms Releases Neutrons, Making Heat

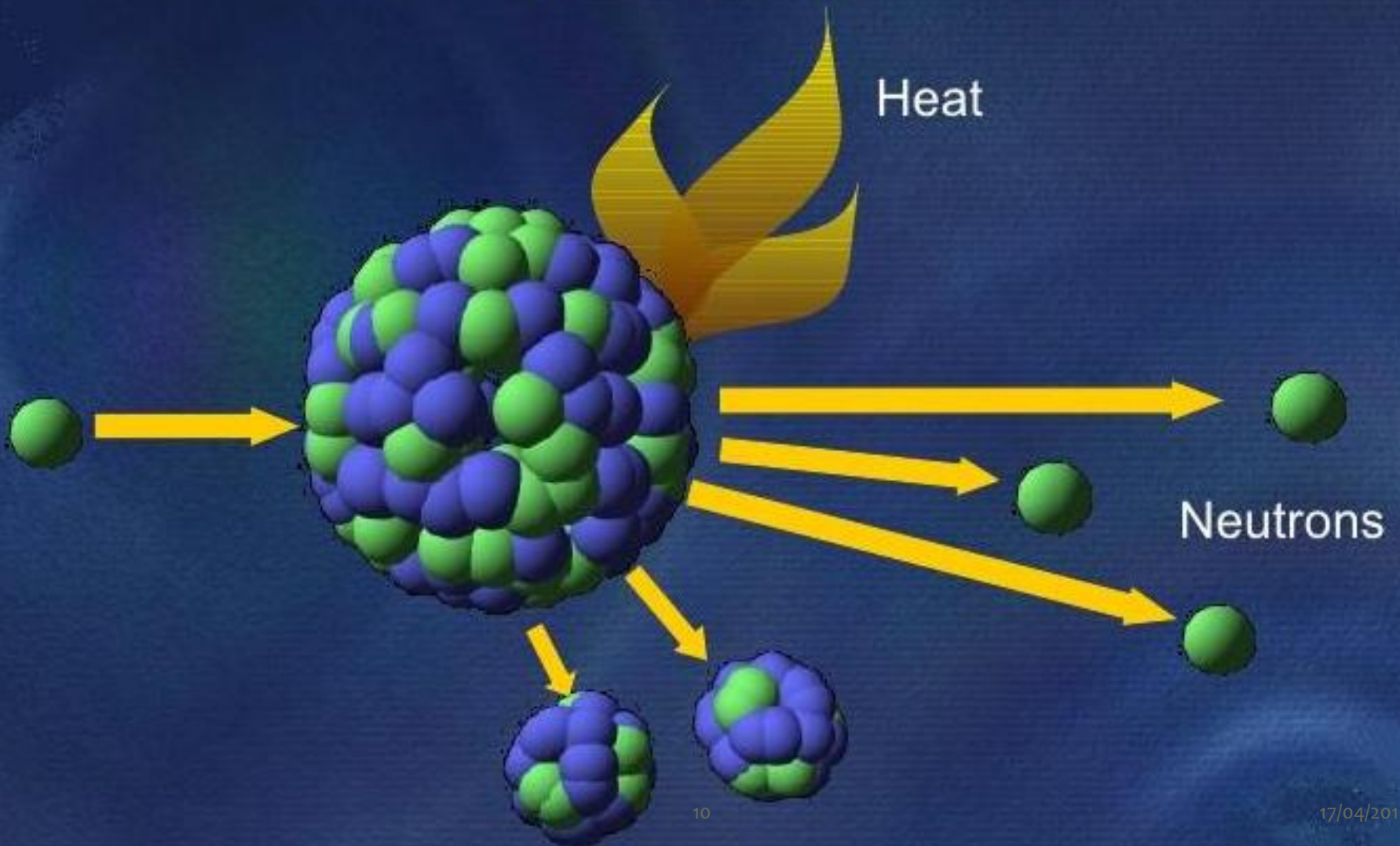

Fissile Materials - U-235, U-233, Pu-239

Fertile Materials - Th-232, U-238.

Fission Reaction

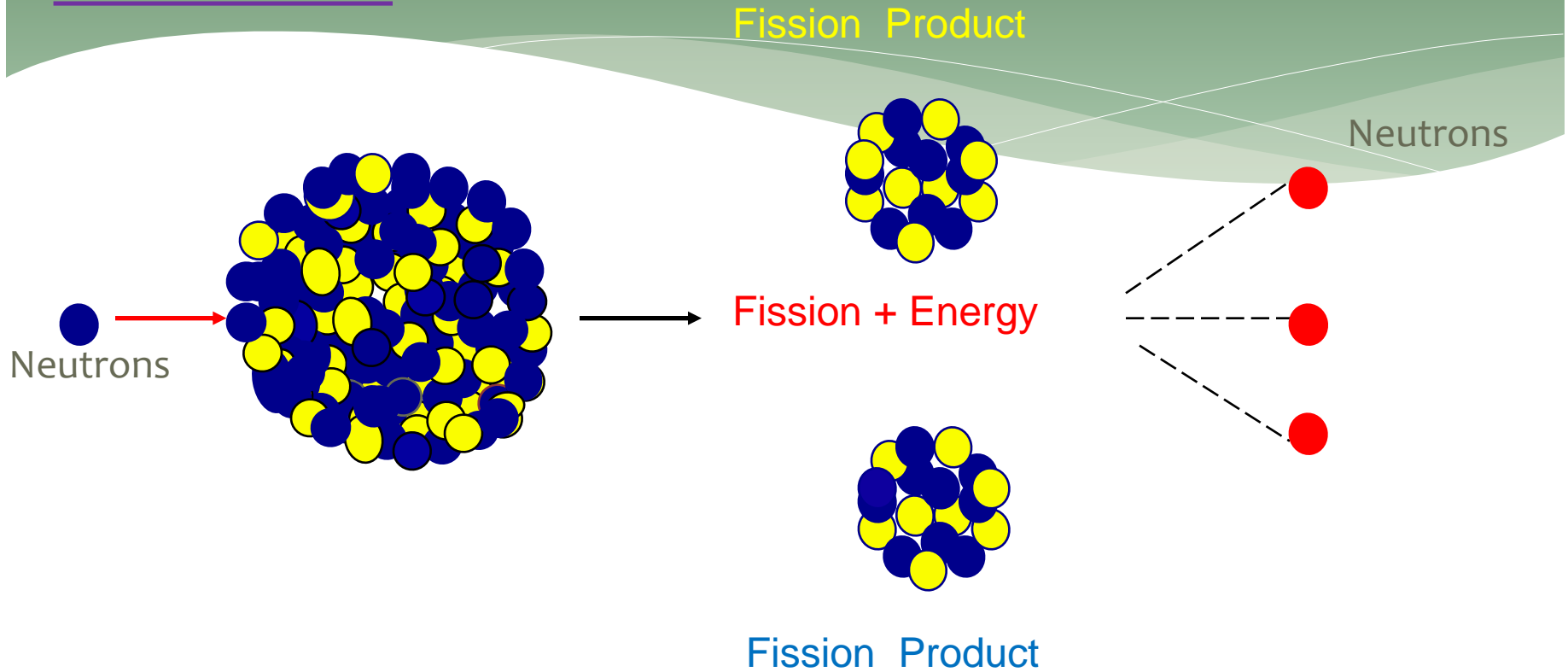

ENERGY RELEASE = 200 MeV per fission

Multiplying chain reaction

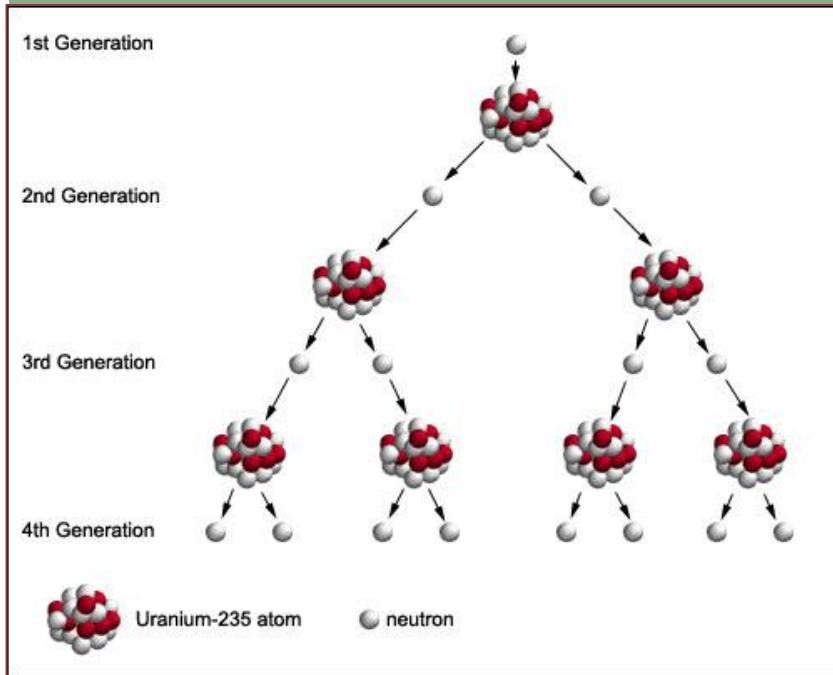

Controlled chain reaction

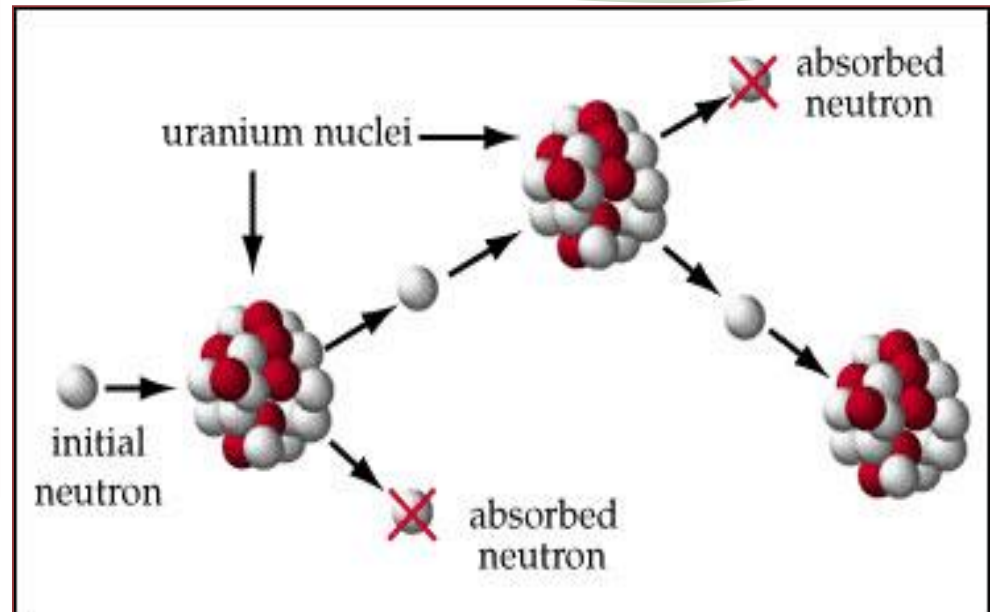

To maintain a sustained controlled nuclear reaction, for every 2 or 3 neutrons released, only one must be allowed to strike another uranium nucleus. If this ratio is less than one then the reaction will die out; if it is greater than one it will grow uncontrolled (an atomic explosion).

Comparison : Chemical & Nuclear Reaction

Thermal Power

Chemical Reaction

(Reaction at

electron level)



Nuclear Power

Nuclear Reaction

(Reaction at Nucleus level)



Approximately 50 million (50×10^6) times more energy

Matter and Energy

- Matter and Energy are two forms of the same thing.
- Matter can be changed into Energy.
- Einstein's $E = mc^2$ formula tells us how this change occurs.

In the equation above:





E = Energy released

m = Mass (Change in mass)

c = Speed of Light (Universal Constant)

- This tells us that a small amount of mass can be converted into a very large amount of energy.

COMPARISON OF ELECTRICITY GENERATION PLANTS (1000 Mwe)

<p>HYDEL</p> 	<p>NUCLEAR</p> 	<p>THERMAL</p> 
<p><u>Land (Hectares)</u> Submerged : 2000-5000</p>	<p><u>Land (Hectares)</u> Required : 20</p>	<p><u>Land (Hectares)</u> Required : 70</p>
<p><u>Resource</u></p> <p>Water</p>	<p><u>Resource</u> Nuclear Fuel : 120 Te/Yr (12 Trucks/Yr @ 10 Te/Truck)</p> 	<p><u>Resource</u> Coal : 38,00,000 Te/Year (3,80,000 Wagons/Yr @ 100 Te/Wagon)</p> 
<p><u>Waste</u></p> <p>Nil</p>	<p><u>Waste</u></p> <p>< 1 Te/Yr</p>	<p><u>Waste</u> CO₂ : 70,00,000 Te/Yr •SO₂ : 45,000 Te/Yr •NO_x : 20,000 Te/Yr¹⁶</p>

Nuclear Power is Clean & Green Power

Comparison of 1000 MW Power Station

Fuel consumption 1000 MWe Coal fired power station

Waste production

↓
About 3 million
tonnes of coal
per year

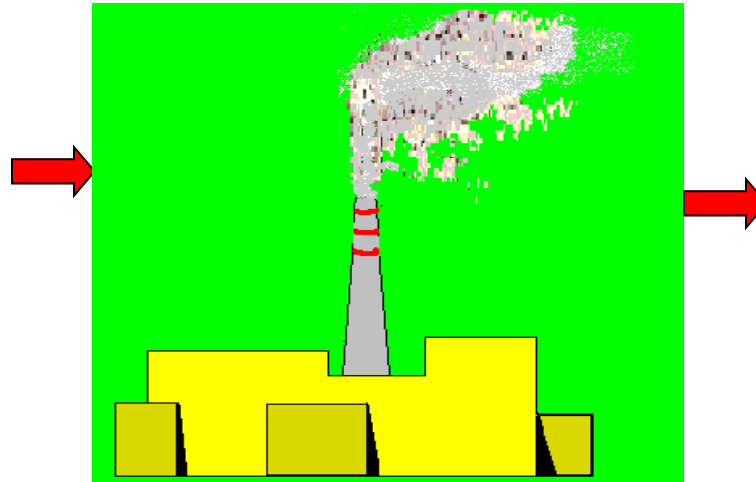

About 7 million of tonnes of waste per year, mostly in the form of gases such as carbon and sulphur dioxides, much of which is released in to the atmosphere. Also 150-200,000 tonnes of solids including fly ash and sulphur.

1000 MWe Nuclear power station

About 25
tonnes of
Uranium each
year

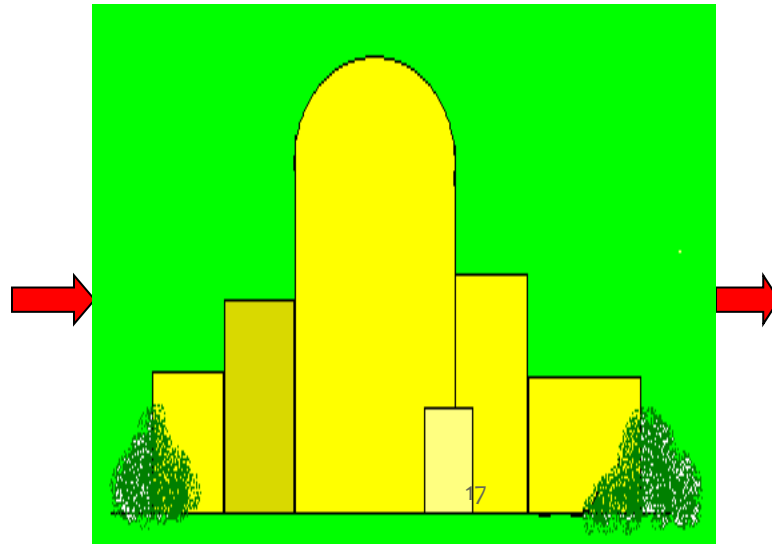

With reprocessing about 1 tonne of high level radioactive waste which is solidified for greater safety and ultimate disposal

Overview of Three Stage Nuclear Power Programme

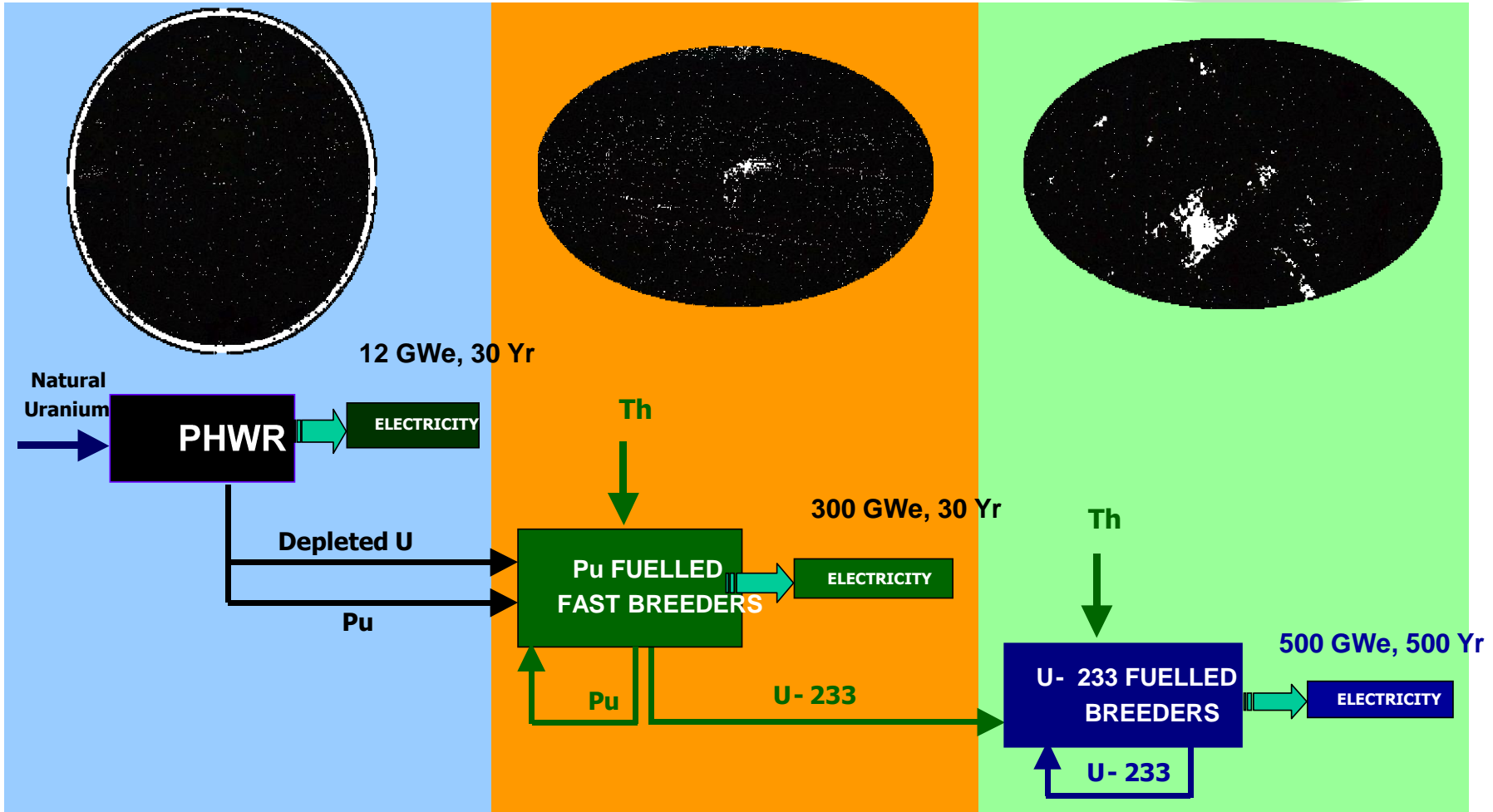

STAGE 1

STAGE 2

STAGE 3

SCHEMATIC REPRESENTATION OF COMPONENTS OF A THERMAL NUCLEAR POWER REACTOR

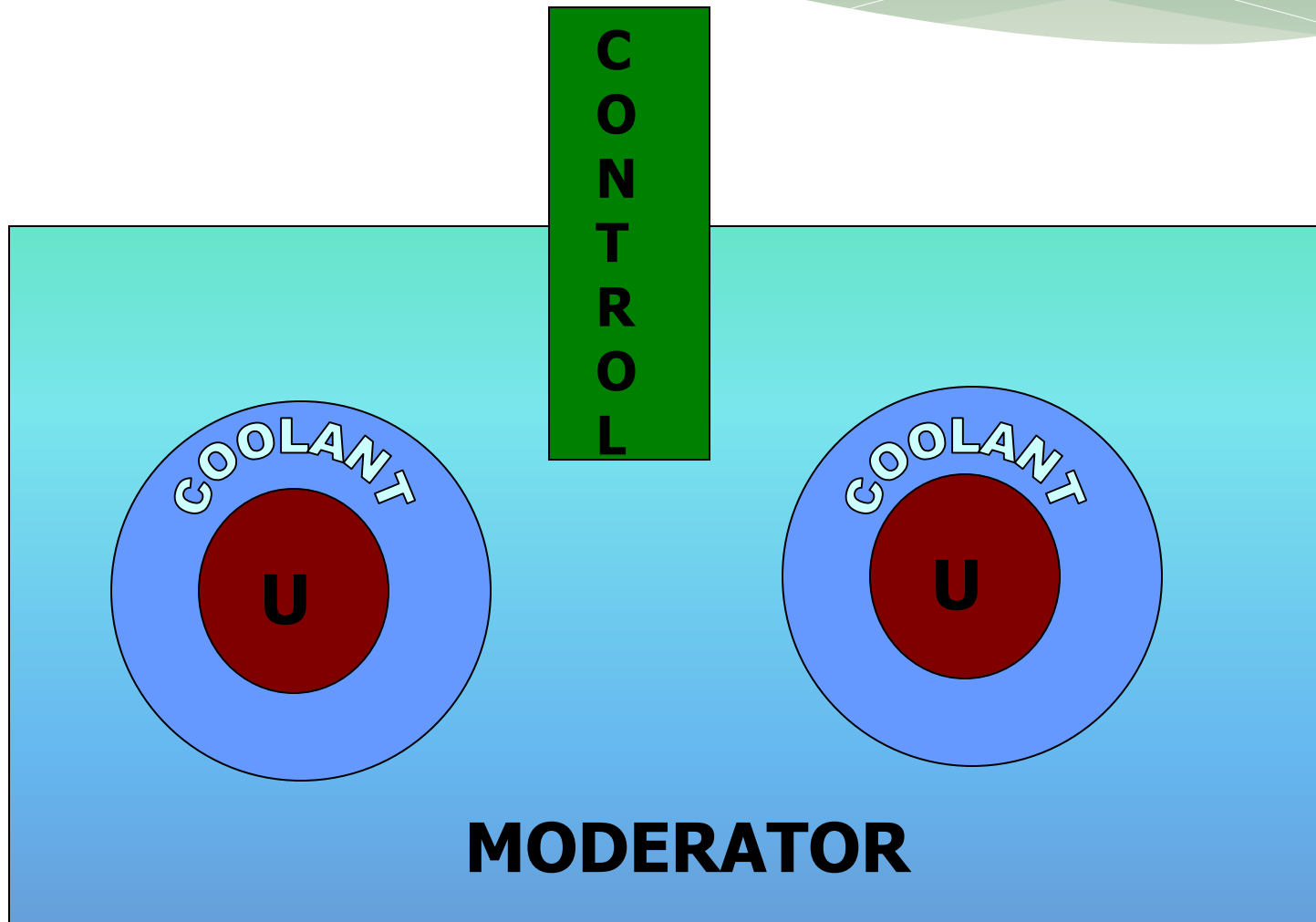

Fuel Bundles (NFC, Hyderabad)

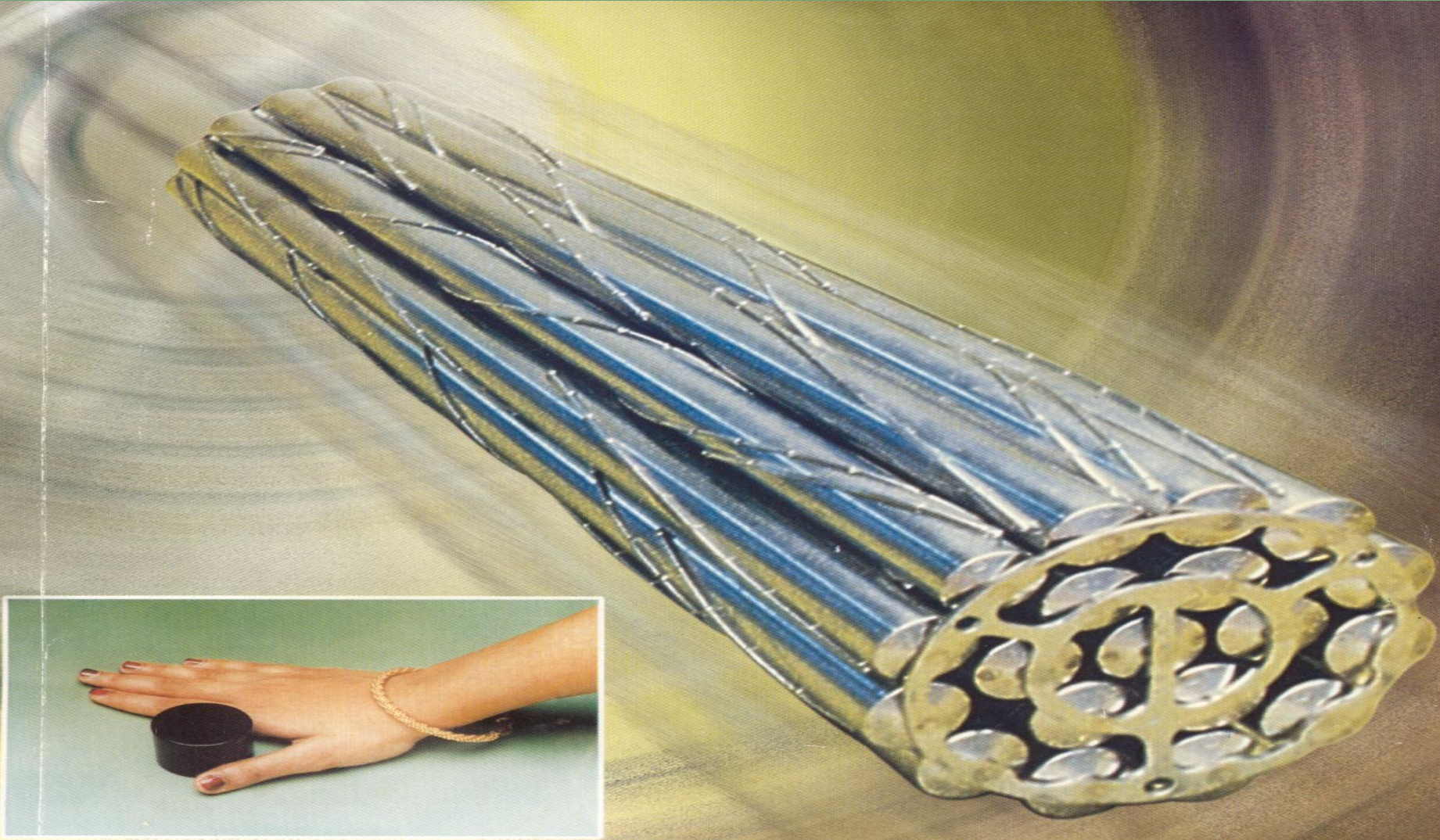

**Fuel required to generate One Million Units of Electricity:
Two bundles 28 Kg (equivalent to about 700 Tonnes COAL)**

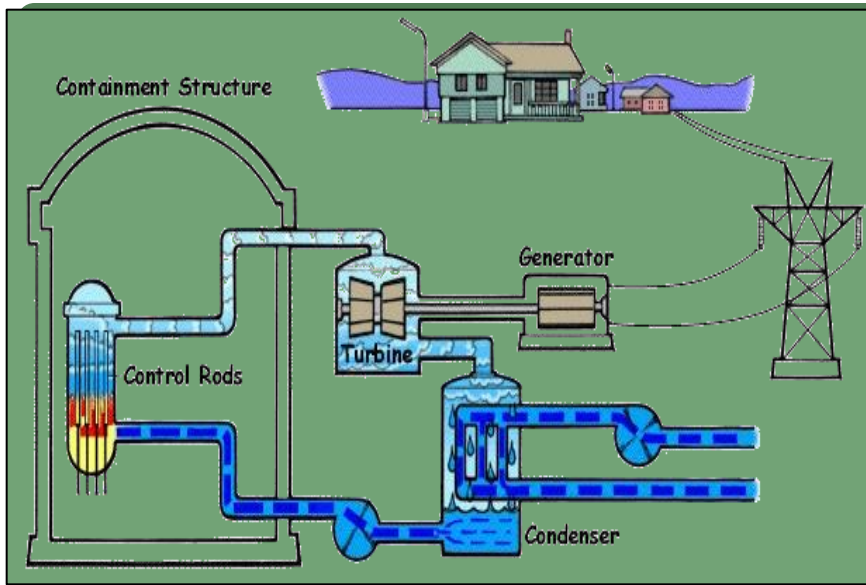

Boiling Water Reactor

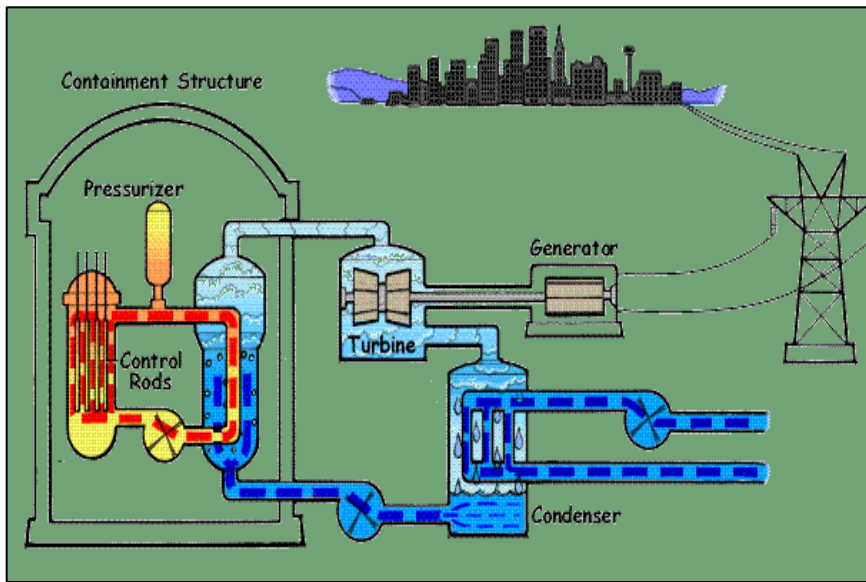

Pressurised Water Reactor

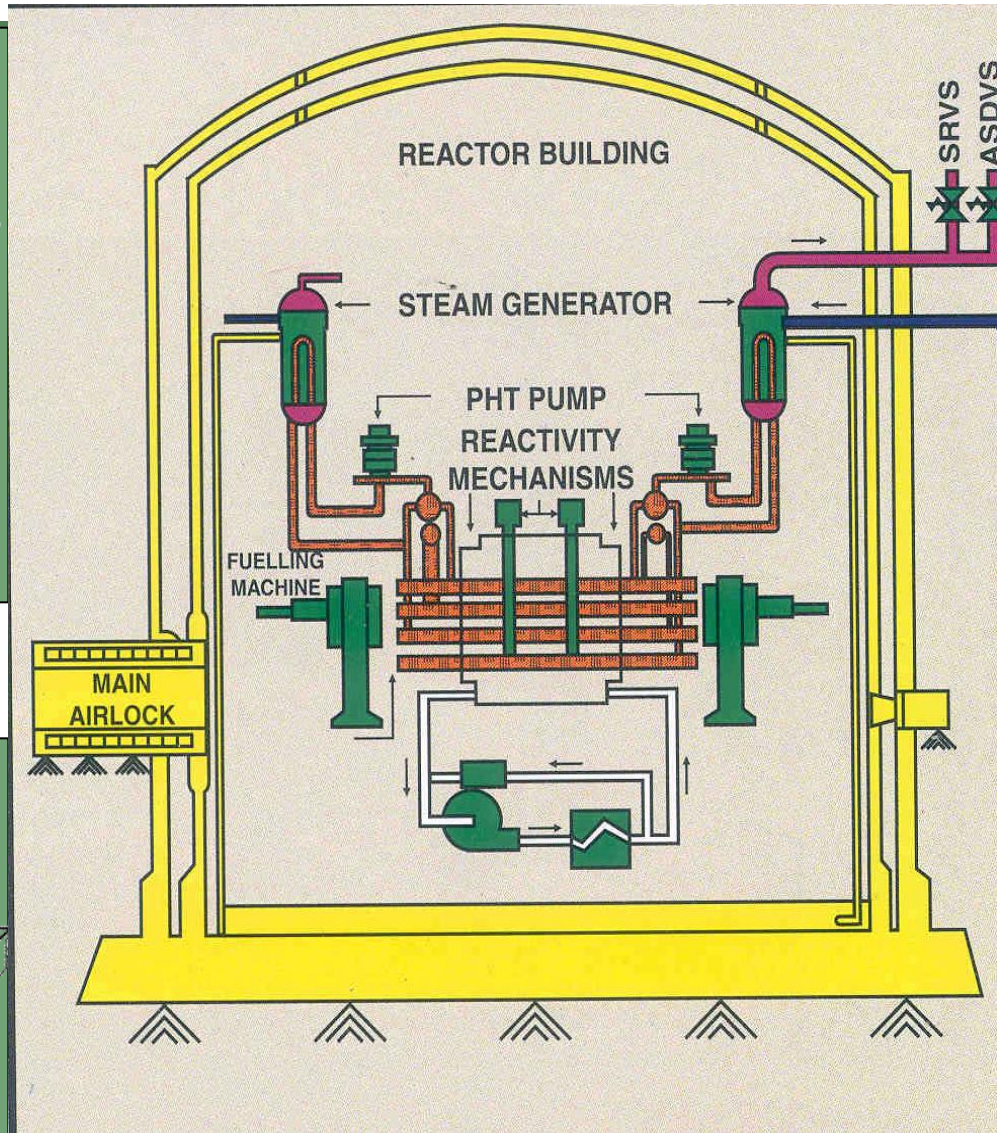

Pressurised Heavy Water Reactor

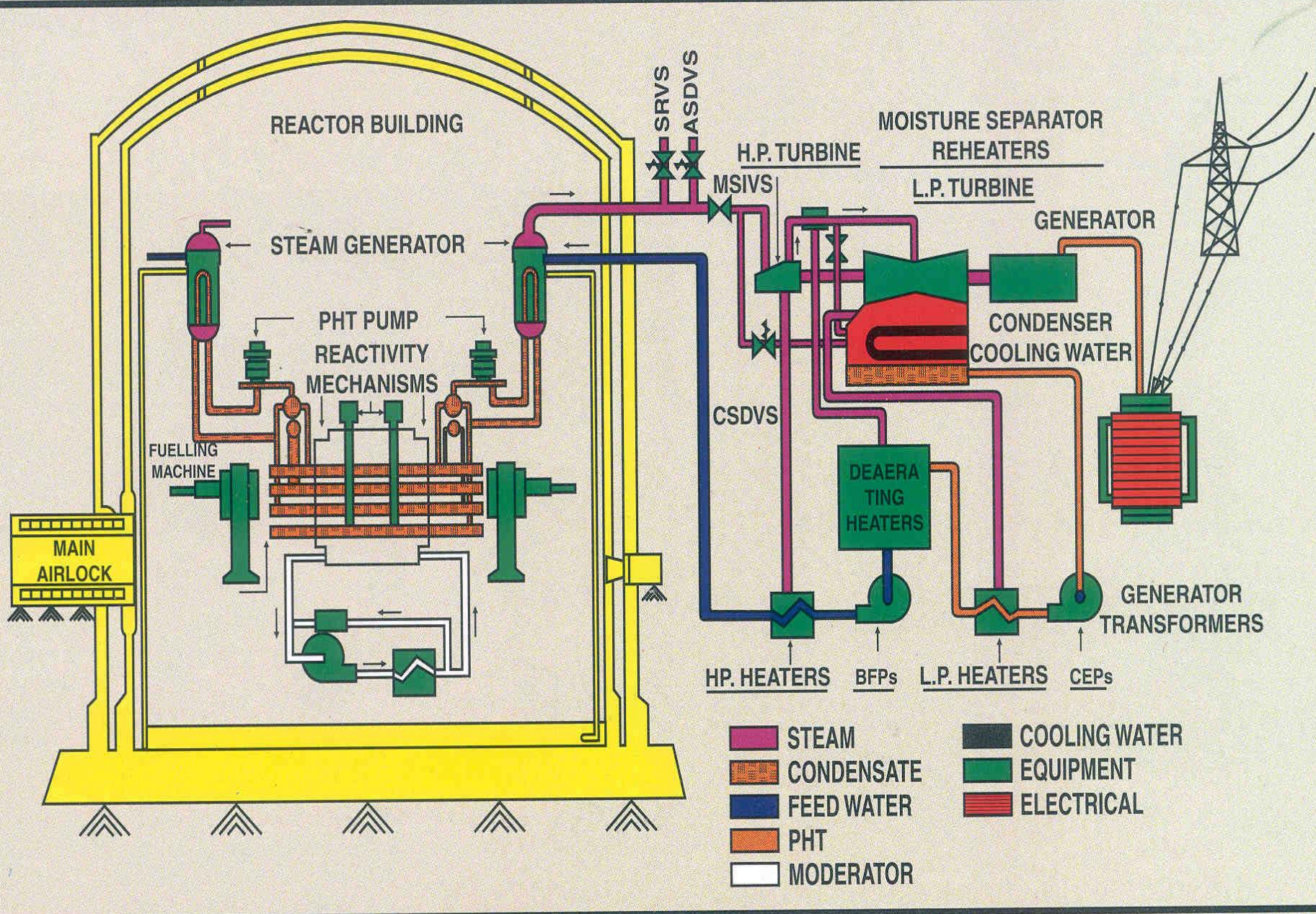

23
Schematic Diagram of Indian PHWR

Safety Features of NPPs

SAFETY CONCEPT

- * The objective of nuclear power plants safety is the protection of individuals, society and the environment from undue radiological hazard so that nuclear power production does not significantly add to the health risks to which individuals and society are already exposed.
 - 1) ALARA during routine operation
 - 2) Minimize the risk to public from accidental release of radioactivity.

Safety features

Defense in depth approach is adopted to ensure Safety of the nuclear power plant from the initial stage of siting to design, construction, operation and emergency preparedness.

Preventive and mitigative provisions are inherent part of the design to achieve three basic safety functions i.e. safe shutdown, core cooling & containment of radioactivity in all conditions.

Safety features

Provision of two independent and diversified shutdown systems.

Primary shutdown system – fail safe gravity driven or Shut Down System -1.

Secondary shutdown system or Shut Down System - 2 – injection of poison through helium pressure.

Safety features

Provision for core cooling along with back up systems as :

Shutdown cooling pump.

Emergency core cooling system.

Core cooling through thermo siphoning.

Diesel driven fire water pumps.

Passive decay heat removal system.

Containment Spray System.

Safety features

Multiple Barriers to contain Radioactivity

Fuel – Melting temperature 2300 deg. C.

Fuel Clad – Zr. Melting temperature 1600 deg. C.

Primary Coolant Circuit – Close loop with thermo siphoning cooling mode.

Primary Containment.

Secondary Containment.

Exclusion Zone – 1.6 KM radius.

Safety features

* Central and local controls

1. Complete information of the station of the plant is available at central as well as local control panels.
2. Functions needing immediate attention are brought invariably to central control room.

* Supplementary control room

Completely independent control and monitoring systems for :

1. Shutdown the plant.
2. Maintain the core cooling of the plant.
3. Long term monitoring of important parameters.

BARRIER TO RELEASE OF RADIOACTIVITY

PRIMARY
CONTAINMENT

SECONDARY
CONTAINMENT

FUEL
CLADDING

FUEL

EXCLUSION ZONE

HEAT
TRANSPORT
SYSTEM

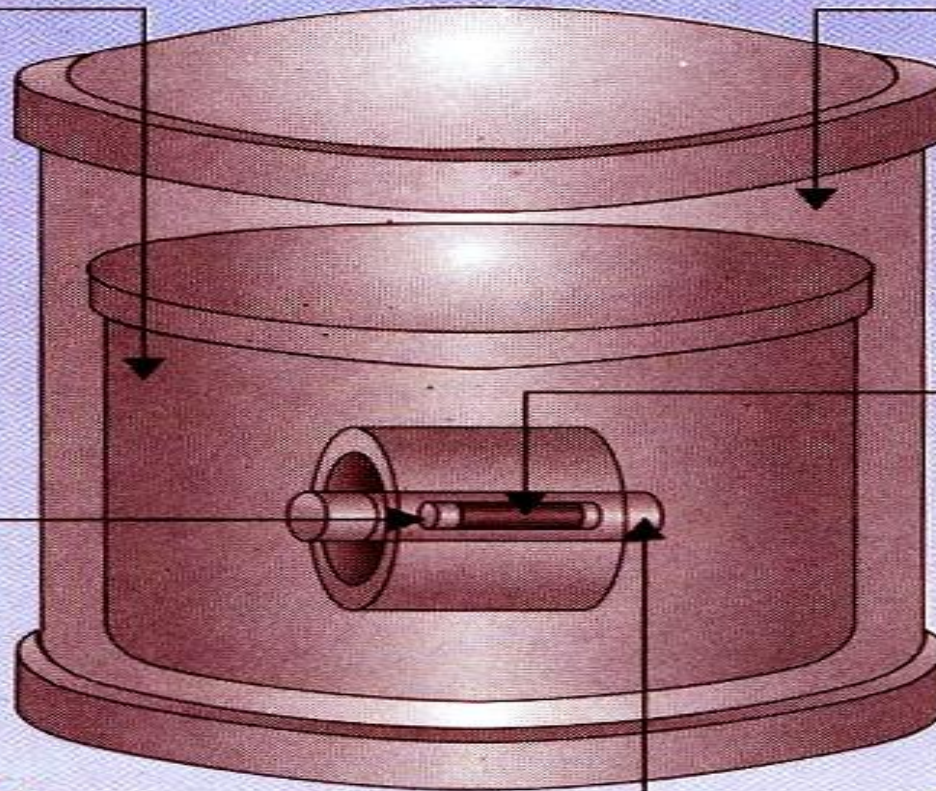

FUNDAMENTAL SAFETY FUNCTIONS

1. Ability to shut down the reactor and maintain it under shutdown (i.e., stop the nuclear fission chain reaction)
2. Ability to keep the core cooled.
3. Ability to contain radioactive fission products, should they get released from fuel.

PRINCIPLES & GUIDELINES:

1. Single Failure Criterion

A random failure, which results in the loss of capability of a component to perform its intended safety function. Consequential failures resulting from a single random occurrence are considered to be part of the single failure.

For example: 2/3 Logic in all safety functions.

PRINCIPLES & GUIDELINES:

2. Fail-safe design

The principle of fail-safe design shall be considered and incorporated into the design of systems and components important to safety for the plant as appropriate: if a system or component fails, plant systems shall be designed to pass into a safe state with no operator action.

For example: On failure of power sensing instrument in one channel it will trip the respective safety channel.

PRINCIPLES & GUIDELINES:

3. Redundancy and Reliability

Provision of alternative structures, systems, components of identical attributes, so that anyone can perform the required function, regardless of the state of operation or failure of other.

For Example: Two shut down systems.

4. Diversity

The presence of two or more different components or systems to perform an identified function, where the different components or systems have different attributes so as to reduce the possibility of common cause failure.

For Example: The two shut down systems working principle is diverse.

PRINCIPLES & GUIDELINES:

5. Common cause Failures

Any event where a single cause or condition caused at least one independent train or channel to become inoperable in multiple systems, or two independent train or channels to become inoperable in a single system that is related to reactor shutdown, decay heat removal, control of the release of radioactive material, or the mitigation of the consequences of an accident.

For Example: Two trains of ECCS, CSS provided.

6. Provision of periodic testability of active component

7. In Service Inspection (ISI)

8. Two Group (Train) Concept

DESIGN PROVISIONS

- * The **design barriers** ensure prevention from unacceptable release of radioactivity in environment during normal condition. e.g. Fuel, Fuel cladding, PHT boundary, Primary containment, Secondary containment, Exclusion boundary.
- * Design also ensure that the possibility of nuclear accident is very remote and release of radioactivity to public domain will take place only in case of failure of number of **design provisions**. e.g. During decay heat removal, core cooling is provided by different means like forced cooling, thermosyphoning, shut down pumps and HX, Passive system like PDHRS, External injection of fire water or ECCS.

DESIGN PROVISIONS

- * In normal course, reactor building containing the nuclear reactor is maintained in **sub atmospheric pressure** by releasing the containment air through stack.
- * Three barriers in form of dampers are provided in reactor building exhaust duct to stack which will close in case of accident.
- * Any release of radioactivity in public domain (stack) during accident will take place only in case of failure of all the three dampers, the possibility of which is very remote.
- * We have emergency management plans for limiting the consequences to general public in case of radioactivity release subsequent to nuclear accident.

- Operational safety is a prime concern for those working in nuclear plants.
- Radiation doses are controlled by the use of remote handling equipment for many operations in the core of the reactor.
- Other controls include physical shielding and limiting the time workers spend in areas with significant radiation levels.
- These are supported by continuous monitoring of individual doses and of the work environment to ensure very low radiation exposure compared with other industries.

Achieving optimum nuclear safety

- Human factors play an important role in nuclear safety. Controls and instrumentation are improved and operator is trained in using error prevention tools so as to reduce the incidents happening due to human factor.
- STAR Principle
- Pre-job briefing
- Post-Job debrief
- Just in Time
- Peer checks
- Procedure adherence

CONCEPT OF DEFENCE IN DEPTH (DID) :

DID-1 The aim of the first level of defence is to prevent deviations from normal operation, and to prevent system failures.

DID-2 The aim of the second level of defence is to detect and intercept deviations from normal operational states in order to prevent anticipated operational occurrences from escalating to accident conditions.

CONCEPT OF DEFENCE IN DEPTH (DID) :

- DID-3** This level of defence, it is assumed that the escalation of certain AOO or PIEs may not be arrested by a preceding level and a more serious event may develop.
- DID-4** The aim of this level is to address severe accidents with extremely low probability of occurrence in which the design basis may be exceeded and to ensure that radioactive releases are kept as low as practicable.
- DID-5** This level of defence is aimed at mitigation of the radiological consequences of potential releases of radioactive materials that may result from severe plant conditions.

	Accident Prevention		Accident Mitigation		Mitigation of radioactivity release
Plant State	Normal Operation (NO)	Anticipated Operational Occurrence (AOO)	Design Basis Accidents (DBA)	Beyond Design Basis Accidents including Severe Accidents (BDBA)	Significant Off Site Releases (not a plant state, but resulting from one)
DID	Level-1	Level-2	Level-3	Level-4	Level-5
Objective	Prevention of abnormal operation and failure	Control of abnormal operation and detection and control of failures	Control of accidents within the plant design basis	Control of severe plant conditions including prevention and mitigation of severe accidents, including confinement protection	Mitigation of radiological consequences of significant release of radioactive materials
Essential Features	Conservative design and quality in construction and operation	Control, limiting and protection systems and other surveillance features	Engineered Safety Systems	Complimentary design features	Off site emergency response



Achieving optimum nuclear safety

- Nuclear power plants are designed to shut down automatically in an **earthquake**.
- Nuclear facilities are designed so that earthquakes and other external events will not jeopardize the safety of the plant. Because of the frequency and magnitude of earthquakes, particular attention is paid to seismic issues in the siting, design and construction of nuclear power plants.
- The seismic design of such plants is based on criteria far more stringent than those applying to non-nuclear facilities. Indian nuclear power plants are designed to withstand two earthquake intensities, OBE and SSE.

Achieving optimum nuclear safety

- **OBE (Operating Basis Earthquake) and SSE(Safe Shut Down Earthquake).**
- The design basis earthquake ground motion OBE is defined as the largest earthquake which can reasonably be expected to occur at the site of a nuclear power plant, based on the known seismicity of the area. A power reactor could continue to operate safely during an OBE level earthquake, though in practice they are set to trip at lower levels.

*

Achieving optimum nuclear safety

- Larger earthquake ground motions in the region, considering the tectonic structures and other factors, must also be taken into account, although their probability is very low. The largest conceivable such ground motion is the design basis earthquake ground motion SSE. The plant's safety systems would be effective during an SSE level earthquake to ensure safe shutdown without release of radioactivity.
- Nuclear power plants are fitted with seismic detectors. If these register ground motions of a set level, usually less than OBE to allow a margin for extra safety, systems will be activated to automatically bring the plant to a safe shutdown. Power reactors are also built on hard rock foundations to minimise seismic shaking.

* TSUNAMIS

- Large undersea earthquakes often cause tsunamis - pressure waves which travel very rapidly across oceans and become massive waves over ten metres high when they reach shallow water, then washing well inland. The December 2004 tsunamis following a magnitude 9 earthquake in Indonesia reached the west coast of India and affected the Kalpakkam nuclear power plant near Madras/Chennai. When very abnormal water levels were detected in the cooling water intake, the plant shut down automatically and was restarted six days later.
- Even for a nuclear plant situated very close to sea level, the robust sealed containment structure around the reactor itself would prevent any damage to the nuclear part from a tsunami, though other parts of the plant might be damaged. No radiological hazard would be likely.

Achieving optimum nuclear safety

- There is a great deal of **international cooperation** on nuclear safety issues, in particular the exchange of operating experience.
- The World Association of Nuclear Operators (WANO) was formed following the Chernobyl accident to maximise the safety and reliability of nuclear plant operation. It held its inaugural meeting in Moscow in 1989. With Regional Centres in Atlanta, Moscow, Paris and Tokyo and a coordinating centre in London, WANO links operators of nuclear power plants. The exchange of information on operating experience is the basis of WANO's various programs. Information and event reports are submitted by each operating organisation to its regional centre where they are reviewed for clarity and completeness and then distributed to all WANO members using an international exchange system.

Achieving optimum nuclear safety

- A key goal of WANO is to conduct peer reviews of all nuclear stations worldwide, to establish a system whereby every plant hosts an outside review of its performance every four years.
- The **International Atomic Energy Agency (IAEA)**, headquartered in Vienna, is the peak international organisation for the peaceful uses of nuclear energy and technology. The IAEA, set up in 1957, is an independent inter-governmental organisation within the United Nations system. The IAEA's areas of international cooperation cover all aspects of reactor operations, the nuclear fuel cycle, radioactive waste management, human health and radiation protection, and safeguards.

Atomic Energy Regulatory Board

The **Atomic Energy Regulatory Board (AERB)** was constituted on November 15, 1983 by the President of India by exercising the powers conferred by Section 27 of the Atomic Energy Act, 1962 (33 of 1962) to carry out certain regulatory and safety functions under the Act.

The mission of the Board is to ensure that the use of ionizing radiation and nuclear energy in India does not cause undue risk to health and the environment.

Functions of AERB

- a) Safety Review and Safety Surveillance including Health Physics Aspects and Emergency
- b) Preparedness of operating NPPs and Research Reactors
- c) Regulatory Inspection and Enforcement in respect of all operating NPPs and Research Reactors
- d) Conducting Periodic Safety Review and Renewal of Authorization
- e) Licensing of the operating personnel and the management staff.
- f) Review of Physical Protection aspects in operating plants

Functions of AERB

- g) Enforcement of Atomic Energy (Safe Disposal of Radioactive Wastes) Rules
- h) Co-ordination with International Atomic Energy Agency (IAEA) for the International Nuclear Event Scale (INES) based reporting of events
- i) Safety Review of Nuclear Projects.
- j) Regulatory Inspection & Enforcement in projects under construction.
- k) Issue of authorizations at various stages of the projects as per established procedures and protocols.
- l) Review of physical protection aspects in projects.

Emergency Plans

- * Though the possibility of occurrence of any emergency situation is very remote, still elaborate plans to handle the emergencies exists so that any exigency can be handled in a systematic way.
- * Periodic exercises are conducted to create awareness and familiarization of the emergency plans.
- * In case of such possibility of release of radioactive materials from the plant into the public domain (Beyond 1.6 Km exclusion boundary) as per the established plan, station authorities will take care of Plant condition, however implementing mitigative actions in public domain will be by District Administration under the directives of OED. OED will be suitably briefed by SED on plant & environmental conditions and implementation of counter measures.

SAFETY BARRIERS

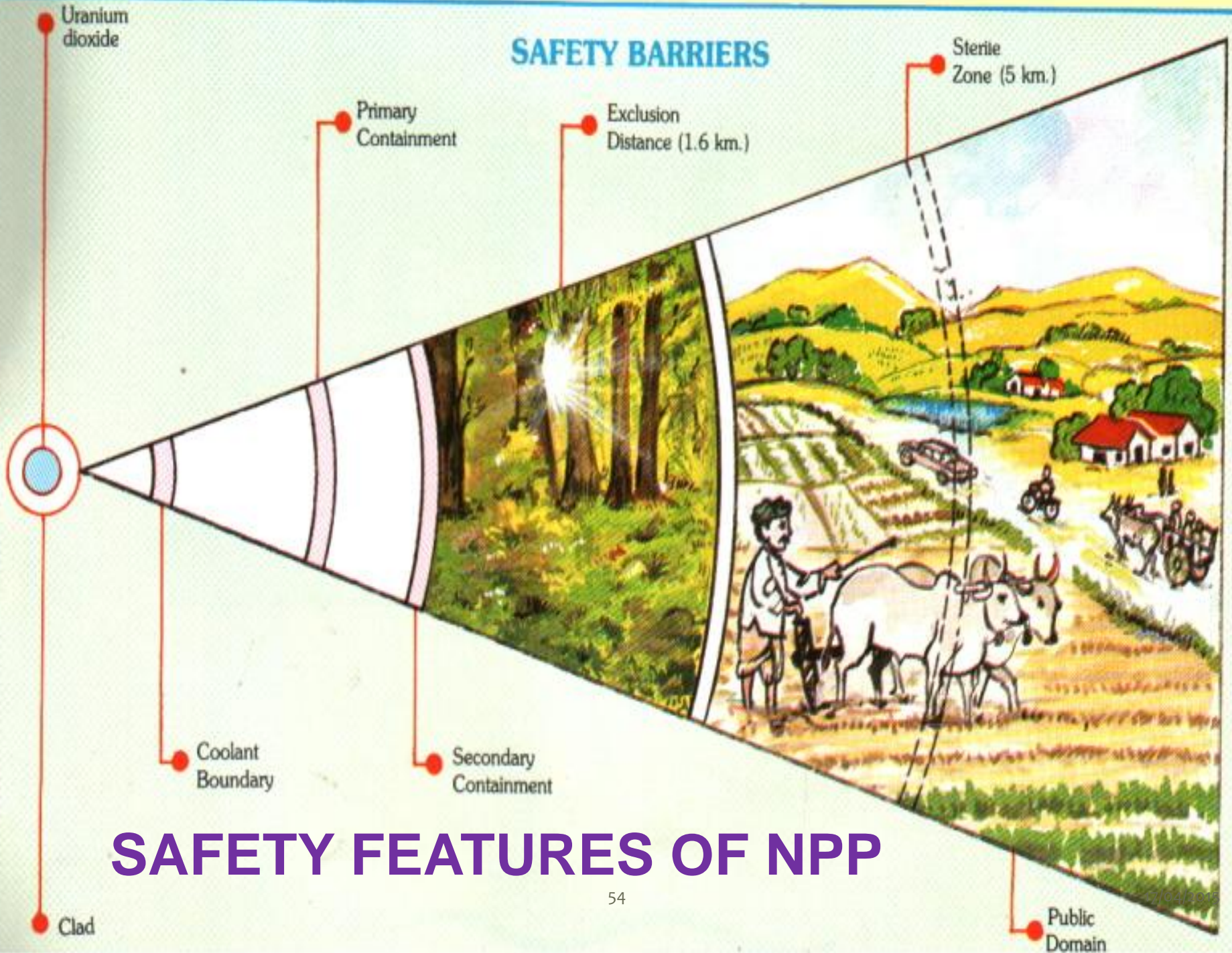

SAFETY FEATURES OF NPP

**Emergency Planning Zone (EPZ)
Action Plans drawn for Public**

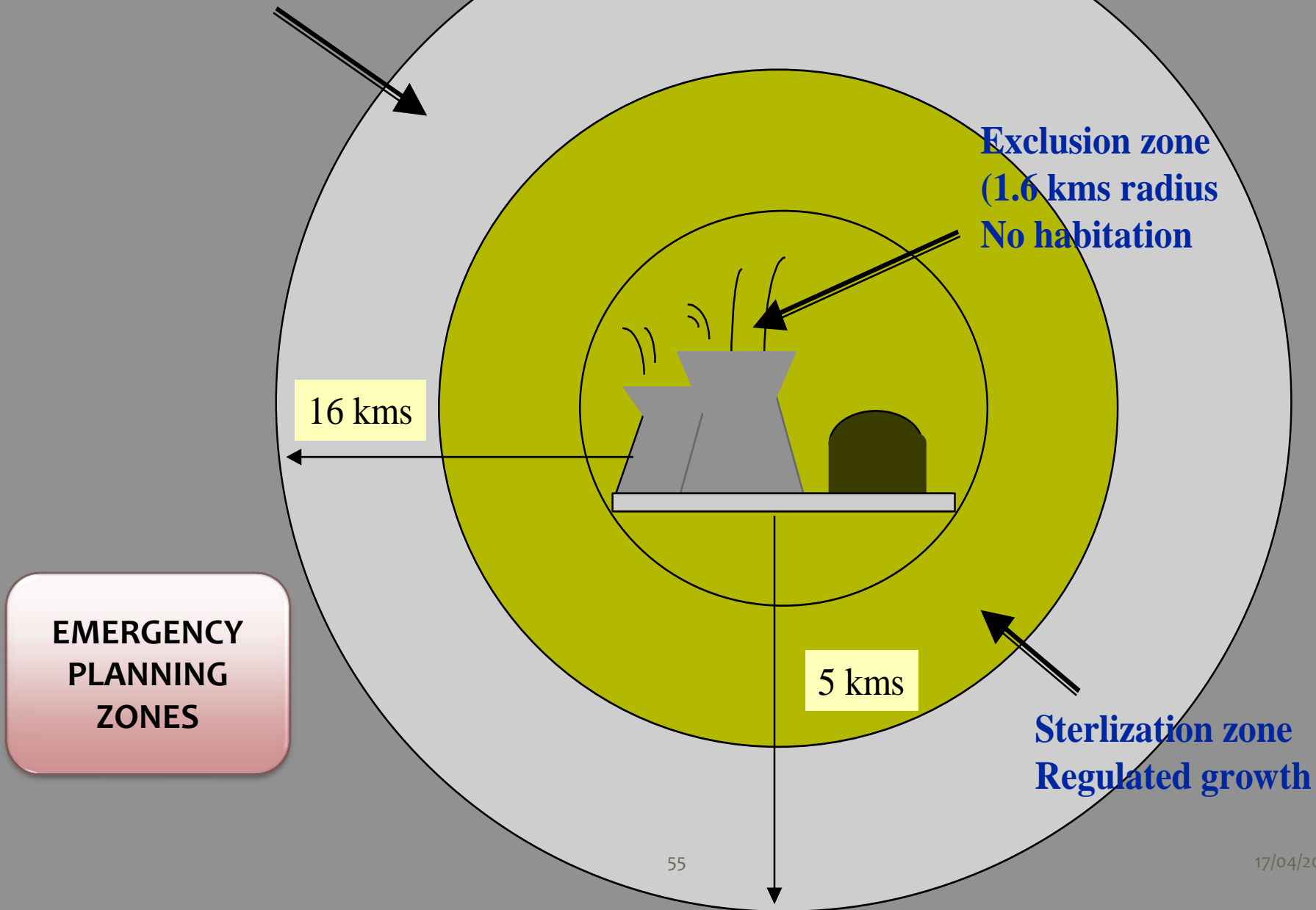

Fukushima Accident

- * New concern has come in every body's mind about nuclear power, after the Fukushima Accident. We can see the facts before us to allay our fear.
- * In spite of the severe earth quake & Tsunami, no single death or bad health effects due to radiation has happened and what ever deaths which have taken place are only due to earth quake & Tsunami effect only.
- * In a nuclear accident, we have enough time available with us due to the design and counter measures are available to stop the possible ill effects.

Review of Indian NPPs after Fukushima

- * It may also be noted that only 3-plants, which were of old design and failure of the authorities to upgrade certain systems have caused the accident
- * Eight plants out of total eleven plants did not get affected.
- * After the Fukushima accident, thorough review of all the nuclear power stations were carried out.
- * The outcome of review is that, our NPPs are capable of withstanding such scenarios.
- * In addition to the above special review, we have periodic safety review every five years to ensure that safety of the plant is continuously reviewed and any up gradation identified based on the international experience, are implemented.

INES SCALE

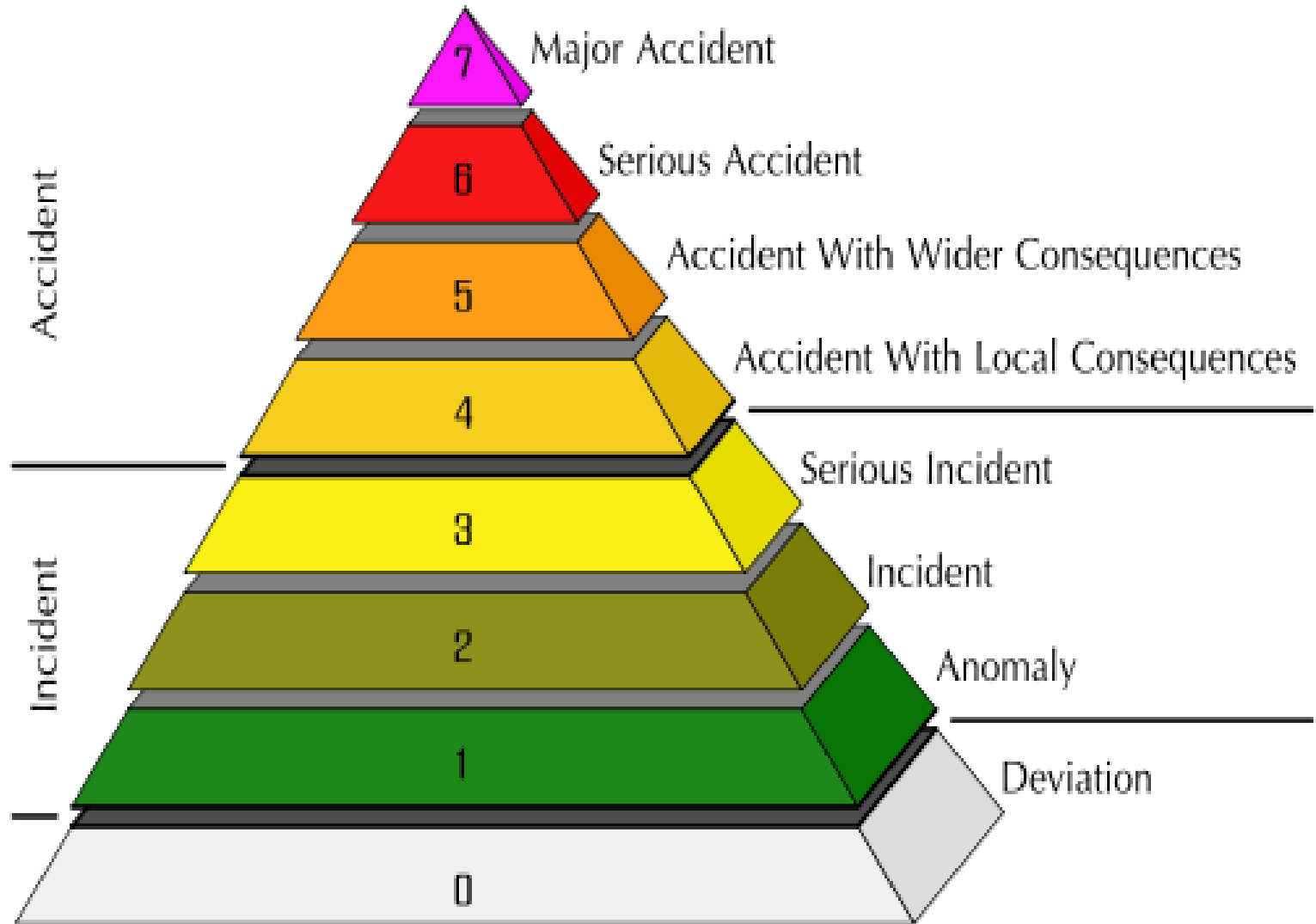

What is INES & its purpose ?

INES is a tool for promptly and consistently communicating to the public the safety significance of events associated with sources of ionizing radiation.

The primary purpose of INES is to facilitate communication and understanding between the technical community, the media and the public on the safety significance of events. The aim is to keep the public as well as nuclear authorities accurately informed on the occurrence and consequences of reported events.

EXAMPLES OF EVENTS AT NUCLEAR FACILITIES

	People and Environment	Radiological Barriers and Control	Defence-in-Depth
7	<i>Chernobyl, 1986</i> — Widespread health and environmental effects. External release of a significant fraction of reactor core inventory.		
6	<i>Kyshtym, Russia, 1957</i> — Significant release of radioactive material to the environment from explosion of a high activity waste tank.		
5	<i>Windscale Pile, UK, 1957</i> — Release of radioactive material to the environment following a fire in a reactor core.	<i>Three Mile Island, USA, 1979</i> — Severe damage to the reactor core.	
4	<i>Tokaimura, Japan, 1999</i> — Fatal overexposures of workers following a criticality event at a nuclear facility.	<i>Saint Laurent des Eaux, France, 1980</i> — Melting of one channel of fuel in the reactor with no release outside the site.	
3	<i>No example available</i>	<i>Sellafield, UK, 2005</i> — Release of large quantity of radioactive material, contained within the installation.	<i>Vandelllos, Spain, 1989</i> — Near accident caused by fire resulting in loss of safety systems at the nuclear power station.
2	<i>Atucha, Argentina, 2005</i> — Overexposure of a worker at a power reactor exceeding the annual limit.	<i>Cadarache, France, 1993</i> — Spread of contamination to an area not expected by design.	<i>Forsmark, Sweden, 2006</i> — Degraded safety functions for common cause failure in the emergency power supply system at nuclear power plant.
1			Breach of operating limits at a nuclear facility.

CONSTITUENTS OF SPENT NUCLEAR FUEL

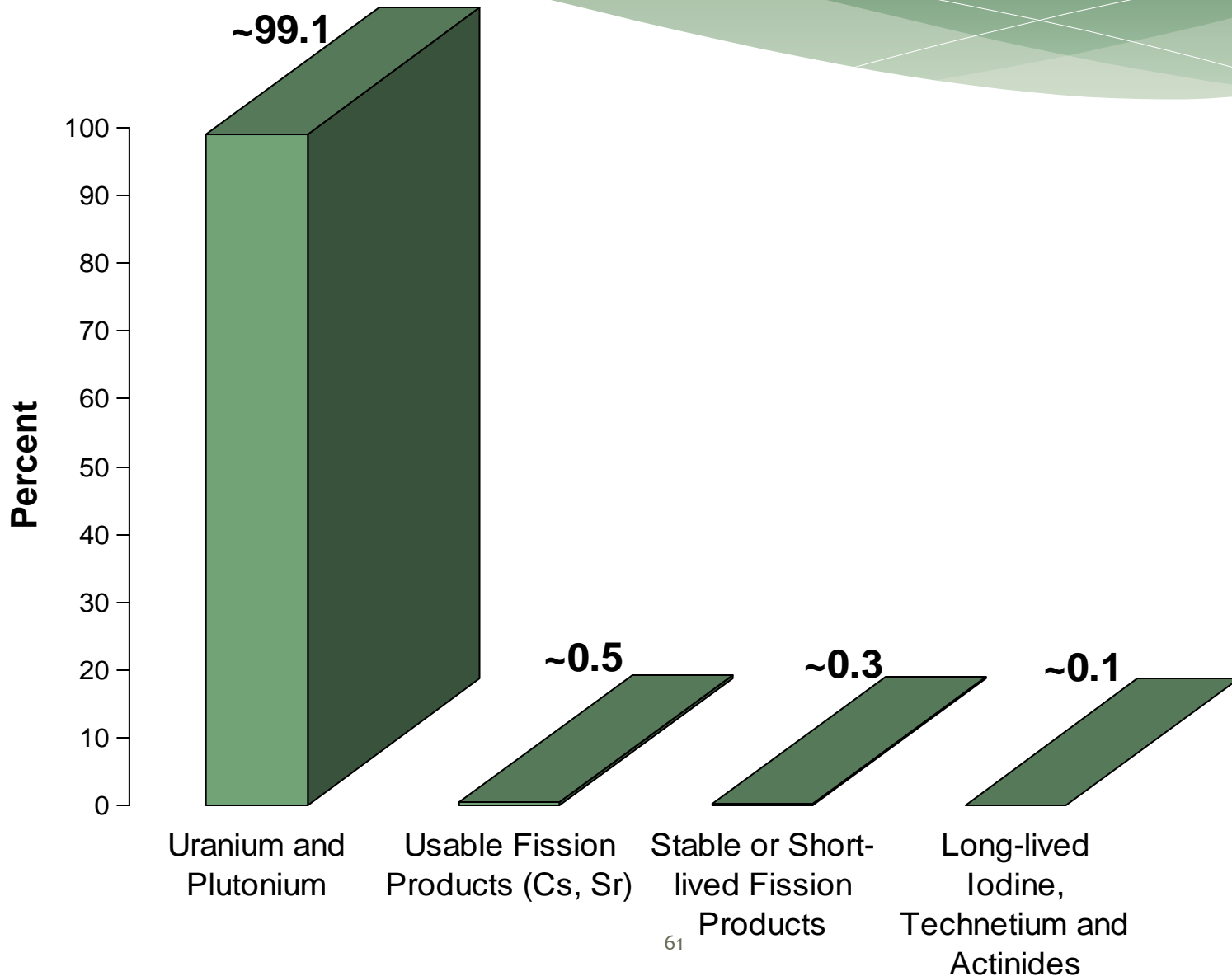

Total Solidified HLW Produced for Generating Electricity For Consumption by an Average Indian Family in 25 Years, if all the Electricity is from Nuclear Power Stations



Radiation Exposure-The right Perspective

Life threatening dose > 3000 mSv

Radiation illness - Passing Symptoms

No symptoms, temporary changes in blood picture (A Skyscraper)

No detectable effects (A House)

Limit for the Occupational Worker (A Man)

Limit for the public (A Brick)

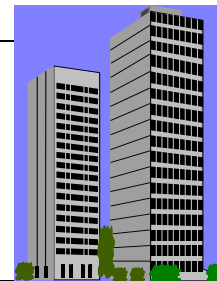
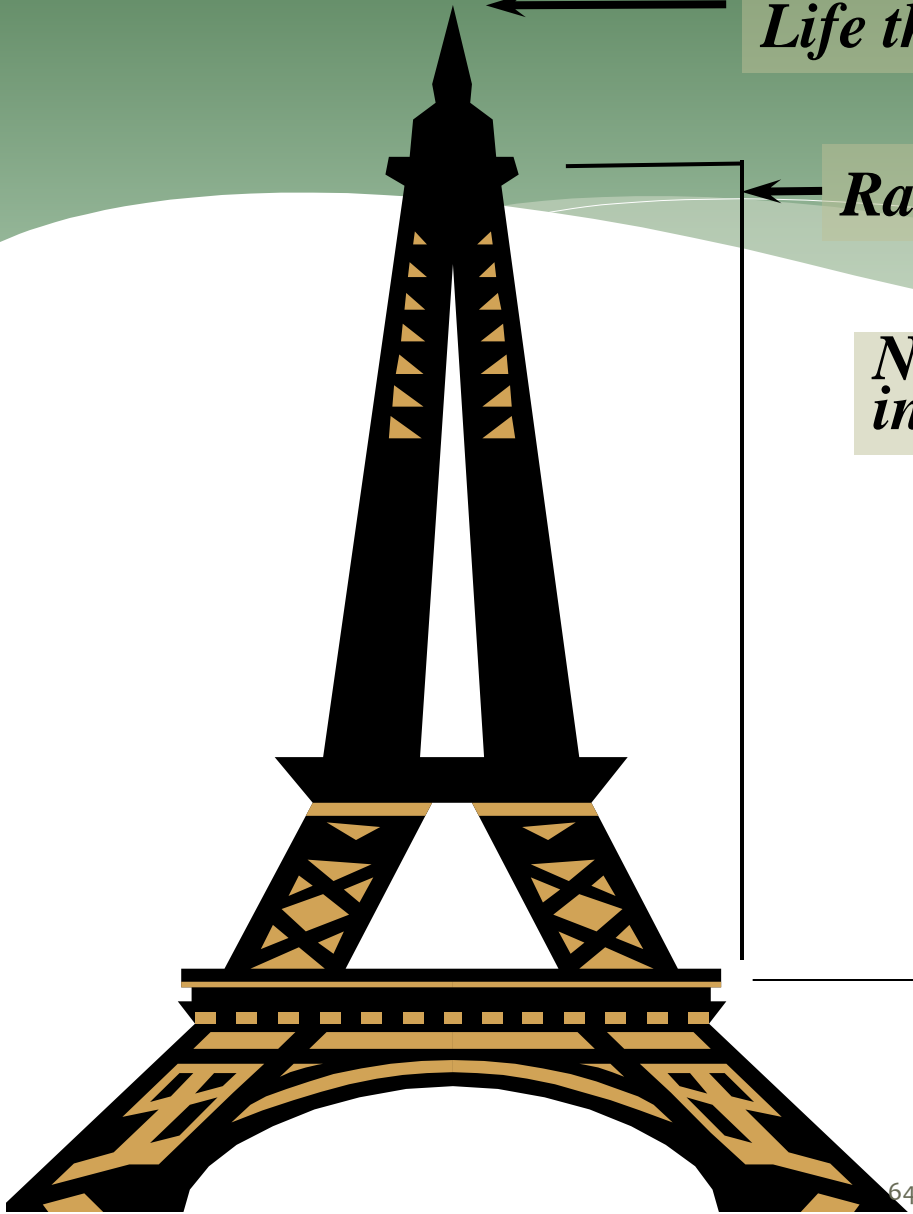

64

17/04/2015

SUMMARY

- ❖ Nuclear Power – a clean, green & benign source of electricity.
- ❖ It is an inevitable option for long term sustainable development
- ❖ It is economically competitive
- ❖ Radioactive waste can be taken care of without much environmental concern
- ❖ Uranium mining is safer, cleaner and much better organised professionally as compared to many other mining industries.



Lesser Golden-backed Woodpecker



Cattle Egret



Sarus Crane



Comb Duck



Alexandrine Parakeet



Red-wattled Lapwing



Indian Roller

Can a NUCLEAR POWER PLANT be a BIRD SANCTUARY? The answer is a resounding YES!

Humans possess the sensibilities to choose technologies that are clean and sustainable. Mankind can live harmoniously with nature, while relishing its innate beauty and grandeur as well as deriving life nourishing support from it.

Atomic Energy is one such technology and Nuclear Power is a green and environment friendly source of electricity. The flourishing flora and fauna in the immediate surroundings of a nuclear power station bear testimony to this. Currently, India has 19 nuclear power plants operating at six locations, namely, Tarapur in (Maharashtra), Rawatbhata (Rajasthan), Kakrapar (Gujarat), Narora (Uttar Pradesh), Kaiga (Karnataka) and Kalpakkam (Tamil-Nadu). The birds in these pictures are either found all the year round in the vicinity of these plants or they regularly migrate there seasonally.



Painted Stork

Flora & Fauna around NPPs



Red-breasted Parakeet



Grey Francolin



Purple Moorhen



Greater Coucal



Greater Flamingo

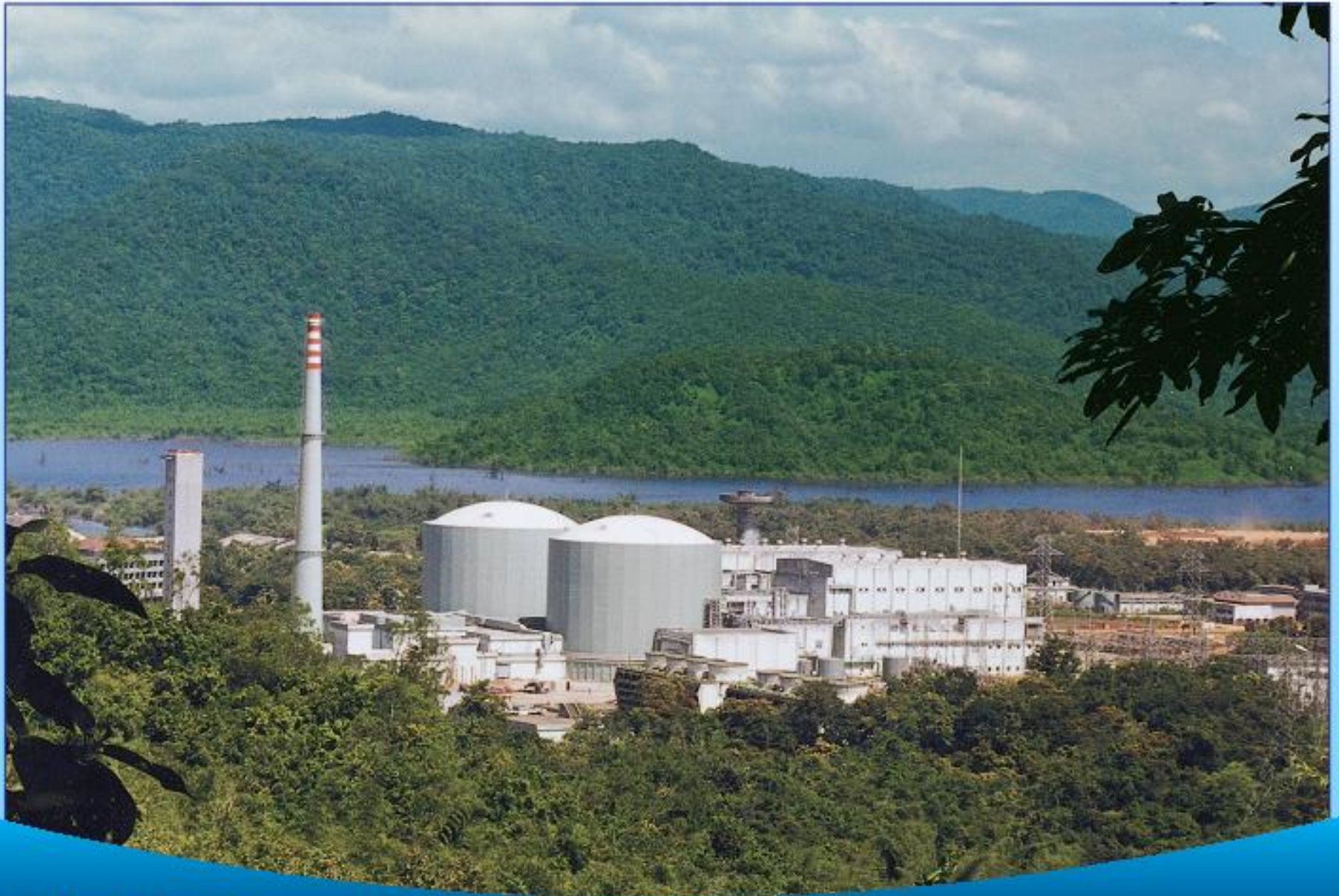

**Nuclear Power Corporation
of India Limited**



**Kaiga Atomic Power Station Unit - 1 & 2
(2x220) MWe, Uttarkanada Dist., Karnataka**



**Nuclear Power Corporation
of India Limited**



**Kaiga Atomic Power Station Unit - 1 to 4
(4x220) MWe, Uttarkanada Dist., Karnataka**



**Nuclear Power Corporation
of India Limited**



**Madras Atomic Power Station Unit - 1 & 2
(2x220) MWe, Chingleput Dist., Tamilnadu**

**Kakrapar Atomic Power Project- 1 & 2
(2x220 MWe), Surat Dist., Gujarat**

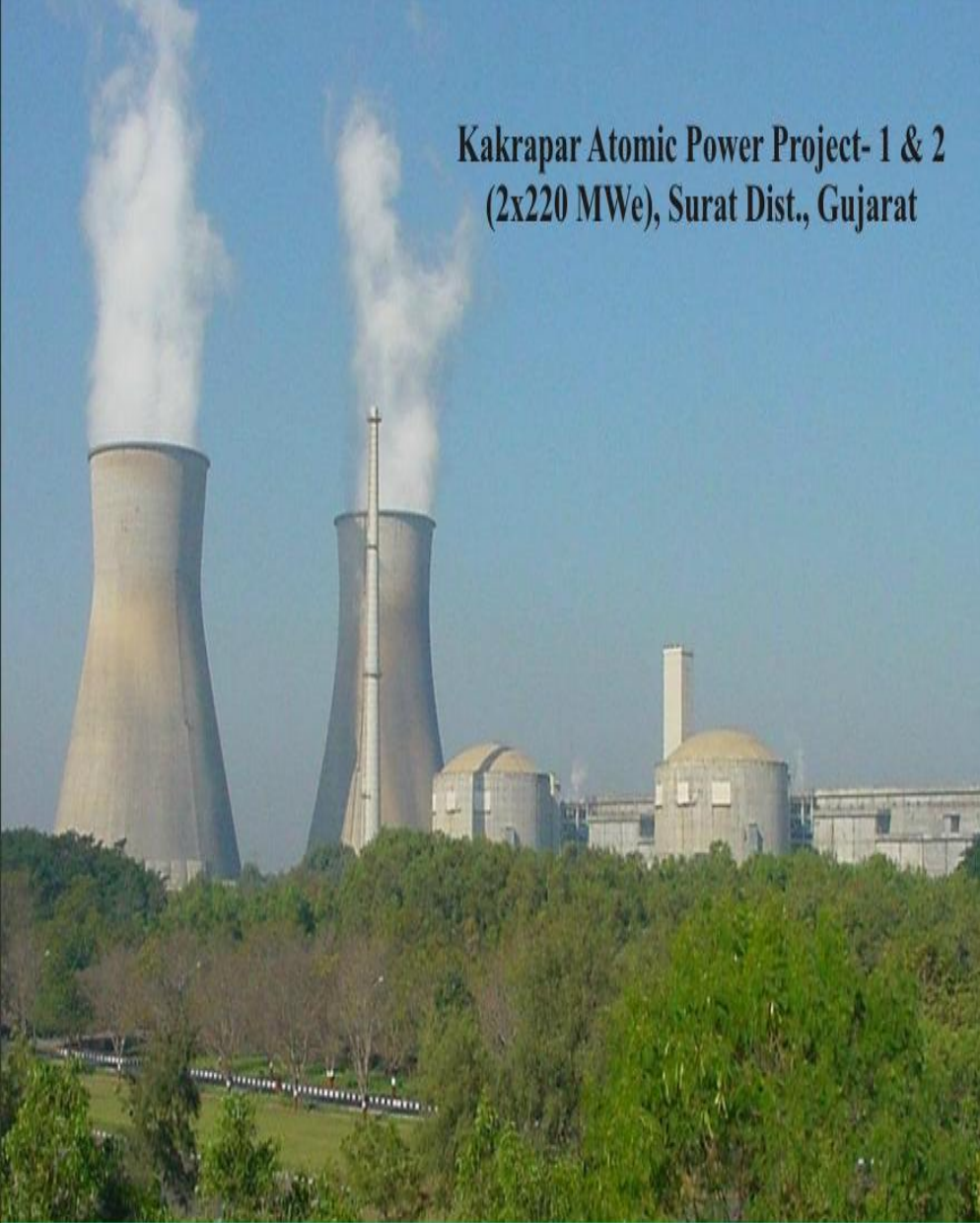

**Kakrapar Atomic Power Project- 3 & 4
(2x700 MWe), Surat Dist., Gujarat**

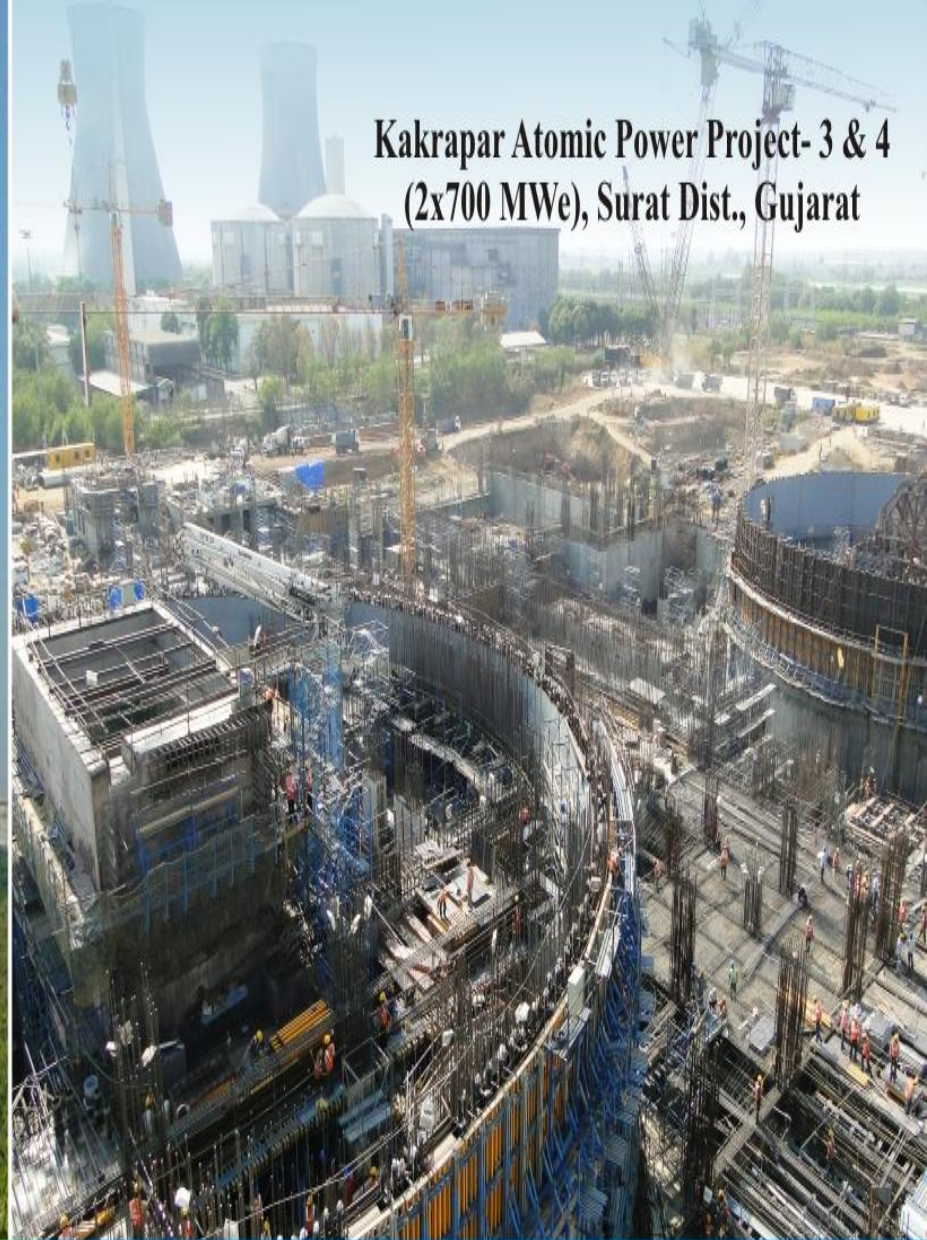

Nuclear Power Corporation of India Limited



**Nuclear Power Corporation
of India Limited**



**Narora Atomic Power Station Unit - 1 & 2
(2x220) MWe, Bulandshahar Dist., Uttar Pradesh**



**Nuclear Power Corporation
of India Limited**



**Narora Atomic Power Station Unit - 1 & 2
(2x220) MWe, Bulandshahar Dist., Uttar Pradesh**



**Nuclear Power Corporation
of India Limited**



**Rajasthan Atomic Power Station Unit - 1 & 2
(1x100 & 1x200) MWe, Chittorgarh Dist., Rajasthan**



**Nuclear Power Corporation
of India Limited**



**Rajasthan Atomic Power Station Unit - 1 to 6
(1x100, 1x200 & 4x220) MWe, Chittorgarh Dist., Rajasthan**

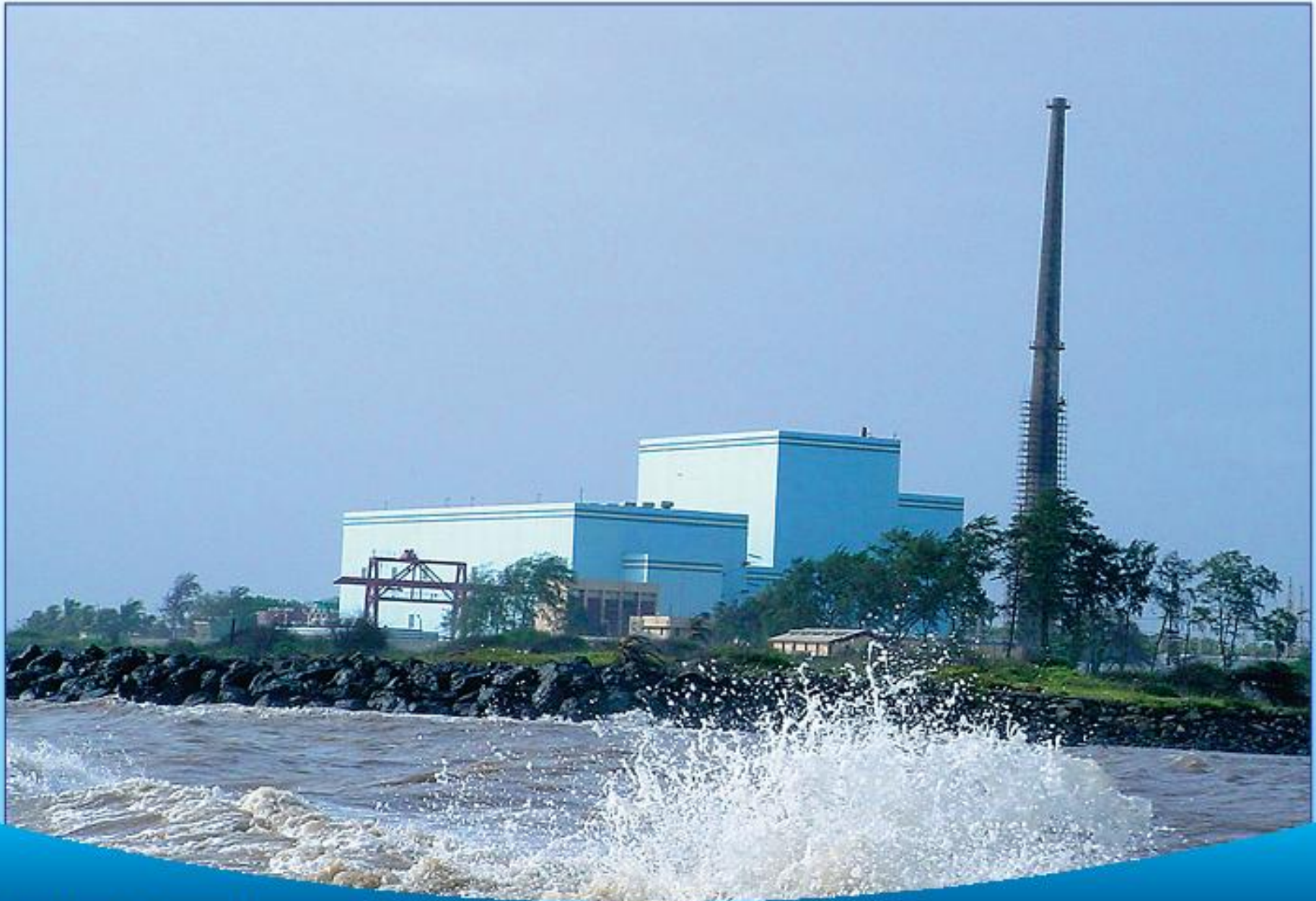

**Nuclear Power Corporation
of India Limited**



**Tarapur Atomic Power Station Unit - 1 & 2
(2x160) MWe, Thane Dist., Maharashtra**



**Nuclear Power Corporation
of India Limited**



**Several design innovations have kept TAPS - 3&4
at the cutting edge of nuclear power technology**



**Nuclear Power Corporation
of India Limited**



**Tarapur Atomic Power Station Unit - 3 & 4
(2x540) MWe, Thane Dist., Maharashtra**



**Nuclear Power Corporation
of India Limited**



**Kudankulam Atomic Power Project Unit - 1 & 2
(2x1000) MWe, Tirunelveli Dist., Tamil Nadu**



End of Presentation

Safety features of Indian PHWRs

Prolonged SBO, Loss of Normal Heat Sink, Severe Accidents

Station Blackout consideration in design is a regulatory requirement

Availability of UHS for a minimum of 7 days is ensured in design.

Passive poison injection to low pressure moderator system (LPIS/GRAB) to achieve long term sub-criticality

Design configuration assists passive decay heat removal by natural circulation of coolant

Diesel engine driven pumps to supply water to SGs and Shutdown cooling HX as back-up

Spent fuel pools with large water inventory which can sustain for longer period without make

No risk of recriticality due to use of natural uranium fuel

Large inventory of water surrounding reactor core (moderator and calandria vault)

Double containment with large volume and provisions for filtered venting

Safety Enhancements in Indian NPPs 1/3

Based on Special safety reviews after major events and PSRs

NAPS : Fire incident, 1993

- Fire in turbine hall, control room, control equipment room, cable trays & cable galleries leading to complete loss of AC & DC power for 17 hours

KAPS : Flooding incident, 1994

- Heavy rain combined with failure to open gates of downstream dam caused submergence of TB basement affecting pumps for essential systems (Loss of normal cooling)

MAPS : Tsunami, 2004

- Tsunami of 4.5m struck MAPS raising water level to 2.0m above DBFL, (0.1m below the grade level of 10.6m). This led to flooding in pump house, resulting in loss of all but one process seawater pump.

Safety Enhancements in Indian NPPs 2

Based on Special safety reviews after major events and PSRs

- Seismic re-evaluation and consequent strengthening of SSCs, where necessary
- Reassessment of DBFL with specific consideration of upstream dam failure for in-land sites
- Reassessment of Tsunami Hazard at all coastal sites
- Construction of 12.2 m high Tsunami protection wall at Kalpakkam
- Installation of additional DGs at higher elevation in old NPPs
- Re-location of UPS system and diesel driven fire water pumps to higher elevation
- Installation of Tsunami early warning system

Safety Enhancements in Indian NPPs 3/3

Based on Special safety reviews after major events and PSRs

Physical separation of redundant trains of safety system (equipment and power & control cables) to avoid CCF

Fire safety enhancement (Strengthening fire barriers, Diverse fire detection methods)

Enhancement in ECCS by addition of high pressure core injection system and modification in ECCS pump suction strainers

Diverse air intake to improve main control room habitability

Incorporation of Supplementary Control Room

Augmentation and hardening of communication systems

Addressing Fukushima

Major recommendations of AERB committee

Higher degree of conservatism in assessment of the intensity and combination of EE (Simultaneous severe EQ and Tsunami not possible)

While safety systems design is governed by DB EE, any cliff edge effects to be avoided

Enhancement of defense-in-depth by use of diverse, physically separated and environmentally hardened systems along with use of passive systems with atmosphere as ultimate heat sink

Look-up provisions to add water to further enhance cooling capability primary system & SF6

Strengthening measures and procedures to deal with severe accident

Creation of environmentally hardened & well equipped emergency response facility with provisions to obtain plant information, communication with concerned agencies and to house essential personnel

Enhancement Measures Identified

● Short term measures

- Enhancing the reliability of cooling through external hook up points
- Review and revising emergency operating procedures
- Training and mock-up exercises of operating personnel

● Medium term measures

- Introduction of seismic trip where it does not exist
- Strengthening backup power supply (air cooled mobile/fixed EDGs at higher elevation)
- Strengthening provision for monitoring of critical parameters under prolonged loss of power
- Steps for augmentation of onsite water storage, wherever required

● Long term measures

- Enhancing Severe Accident Management programme
- Creation of an emergency response facility capable of withstanding severe flood, cyclone & earthquake etc.

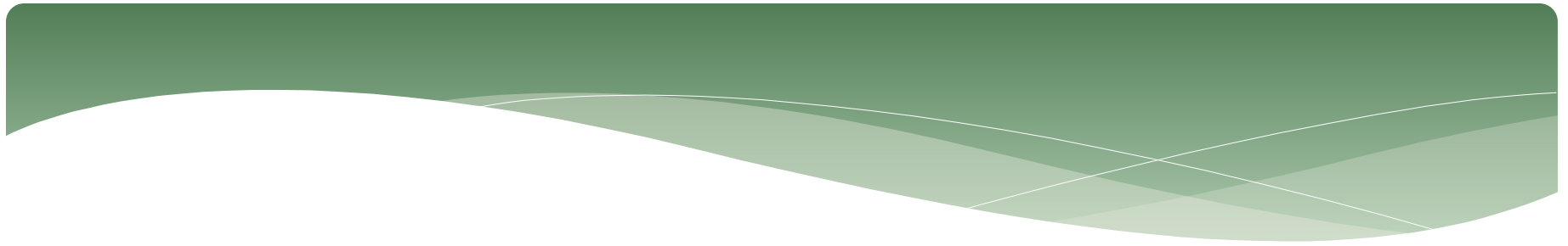

Reactor Accidents, Causes and Lessons Learned

Reactor accident	Severity (INES)	Safety function lost	Root cause	Lessons learned
Three Mile Island 2 USA 1979	5	Cooling	Lack of operator training. Failure in the man - Machine interface.	Need for human performance programs and improved instrumentation and information.
Chernobyl 4 USSR (Ukraine) 1986	7	Control of reactivity	Lack of safety culture. Flaws in reactor design.	Need for improved exchange on good practice across the industry, including the fostering of a safety culture .
Fukushima Daiichi (Units 1-4), Japan 2011	7	Cooling	Failure to consider worst case accident scenarios.	Need for better emergency preparedness and response to improve resilience against natural hazards and other extreme events.